

LUXEON Versat 2020 PCA 150

Industry-leading solutions for exterior automotive lighting

LUXEON Versat 2020 is the industry-leading compact solution for modern automotive signaling applications. This family of products provides design flexibility, automotive reliability and ease of integration/manufacturing to facilitate simplified system integration for high volume automotive designs. The LUXEON Versat 2020 PCA 150 LED is designed to meet the needs of exterior automotive signal lighting applications. All LUXEON Versat 2020 LEDs are AEC-Q102 qualified and cold binned at 25 °C.

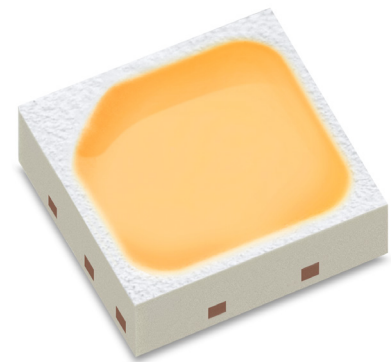

FEATURES AND BENEFITS

- Industry standard footprint for simple integration
- Optimized package drives efficient light extraction
- Low Z profile simplifies optical design and minimizes design space
- Industry leading efficacy

PRIMARY APPLICATIONS

- Side Marker
- Turn
 - Front Turn
 - Rear Turn

Table of Contents

General Information	2
Product Test Conditions	2
Part Number Nomenclature	2
Environmental Compliance	2
Performance Characteristics	3
Product Selection Guide	3
Optical Characteristics	3
Electrical and Thermal Characteristics	3
Characteristic Curves	5
Spectral Power Distribution Characteristics	5
Light Output Characteristics	5
Forward Current and Forward Voltage Characteristics	6
Color Shift Characteristics	7
Radiation Pattern Characteristics	8
Operating Limits Characteristics	9
Permissible Pulse Handling Characteristics	9
Product Bin and Labeling Definitions	10
Designing with LUXEON Versat 2020 PCA 150	10
Decoding Product Bin Labeling	10
Luminous Flux Bins	10
Color Codes	11
Forward Voltage Bins	12
Mechanical Dimensions	12
JEDEC Moisture Sensitivity	12
Packaging Information	13
Pocket Tape Dimensions	13
Reel Dimensions	13
Product Labelling	14

General Information

Product Test Conditions

LUXEON Versat 2020 PCA 150 is tested and binned using a 20 ms monopulse (MP) at 150 mA drive current, case temperature, T_c of 25 °C.

Part Number Nomenclature

Part numbers for LUXEON Versat 2020 PCA 150 follow the convention below:

A 1 V B – **A B C D E F G H J K M N P**

Where:

- A – designates product segment (A = Automotive)
- 1 – designates product level (1 = Level 1)
- V – designates product line/family (V = LUXEON Versat)
- B – designates package size (B = 2020)
- A B C D** – designates dominant wavelength (P591 = PC Amber)
- E** – designates binning current (A = 150 mA)
- F** – open space (0 = standard part)
- G** – designates generation (1 = first generation)
- H** – designates option for selective binning (0 = standard part)
- J K M N** – designates minimum luminous flux (0030 = 30 lumens, 0033 = 33 lumens etc.)
- P** – open space (0 = standard part)

Therefore, the following part number is used for a LUXEON Versat 2020 PCA 150 with a minimum luminous flux of 33 lumens:

A 1 V B – **P 5 9 1 A 0 1 0 0 0 3 3 0**

Environmental Compliance

Lumileds LLC is committed to providing environmentally friendly products to the solid-state lighting market. LUXEON Versat 2020 PCA 150 is compliant to the European Union directives on the restriction of hazardous substances in electronic equipment, namely the RoHS Directive 2011/65/EU and REACH Regulation (EC) 1907/2006. Lumileds LLC will not intentionally add the following restricted materials to its products: lead, mercury, cadmium, hexavalent chromium, polybrominated biphenyls (PBB) or polybrominated diphenyl ethers (PBDE).

Performance Characteristics

Product Selection Guide

Table 1. Product selection for LUXEON Versat 2020 PCA 150 at 20 ms MP, 150 mA, $T_c = 25\text{ }^\circ\text{C}$

COLOR	MINIMUM LUMINOUS FLUX ^[1] (lm)	TEST CURRENT (mA)	PART NUMBER
PC Amber	30	150	A1VB-P591A01000300
	33	150	A1VB- P591A01000330
	36	150	A1VB- P591A01000360

Notes for Table 1:

- Lumileds maintains a tolerance of $\pm 10\%$ on luminous flux measurements.

Optical Characteristics

Table 2. Typical optical characteristics for LUXEON Versat 2020 PCA 150 at 20 ms MP, 150 mA, $T_c = 25\text{ }^\circ\text{C}$

PART NUMBER	DOMINANT WAVELENGTH ^[1,2] (nm)		SPECTRAL HALF-WIDTH ^[3] (nm) $\Delta\lambda_{1/2}$	TOTAL INCLUDED ANGLE ^[4] $\theta_{0.90V}$	TYPICAL VIEWING ANGLE ^[5] $2\theta_{1/2}$
	MINIMUM	MAXIMUM			
A1VB-P591A010xxxx0	588.8	592.6	85.0	138°	120°

Notes for Table 2:

- Dominant wavelength is derived from the CIE Chromaticity diagram and represents perceived color.
- Lumileds maintains a tolerance of $\pm 1\text{ nm}$ for dominant wavelength measurements.
- Spectral width at $\frac{1}{2}$ of the peak intensity.
- Total angle at which 90% of total luminous flux is captured.
- Viewing angle is the off axis angle from the LED centerline where the luminous intensity is $\frac{1}{2}$ of the peak value.

Electrical and Thermal Characteristics

Table 3. Typical electrical and thermal characteristics for for LUXEON Versat 2020 PCA 150 at 20 ms MP, 150 mA, $T_c = 25\text{ }^\circ\text{C}$

PART NUMBER	FORWARD VOLTAGE ^[1] (V_f)		THERMAL RESISTANCE— JUNCTION TO CASE ($^\circ\text{C}/\text{W}$)			
			$R\theta_{j-c}\text{ el}^{[2]}$		$R\theta_{j-c}\text{ real}^{[3]}$	
	MINIMUM	MAXIMUM	TYPICAL	MAXIMUM	TYPICAL	MAXIMUM
A1VB-P591A010xxxx0	2.70	3.49	16.0	20.0	22.0	34.0

Notes for Table 3:

- Lumileds maintains a tolerance of $\pm 0.06\text{ V}$ on forward voltage measurements.
- $R\theta_{j-c}\text{ el}$: Electrical thermal resistance (junction to case).
- $R\theta_{j-c}\text{ real}$: Real thermal resistance (junction to case) with wall plug efficiency included. Reference JESD51-51, JESD51-14, 4.1.3.

Absolute Ratings

Table 4. Absolute ratings for LUXEON Versat 2020 PCA 150

PARAMETER	PERFORMANCE
Minimum DC Forward Current	30 mA
Maximum DC Forward Current	250 mA
Maximum Junction Temperature ^[1]	150 °C
Operating Case Temperature at Test Current ^[1]	-40°C to 125 °C
Operating Case Temperature at Maximum Current ^[1]	-40°C to 125 °C
LED Storage Temperature	-40°C to 130 °C
Soldering Temperature	260 °C
Allowable Reflow Cycles	3
ESD Sensitivity ^[2]	±8 kV HBM, ±400V MM, ±2kV CDM
Reverse Voltage ($V_{reverse}$)	LUXEON LEDs are not designed to be driven in reverse bias

Notes for Table 4:

1. Proper current derating must be used to maintain junction temperature below the maximum. LUXEON Versat LEDs driven at or above maximum LED case temperature may have shorter lifetime.
2. Measured using human body model (per JESD22 A114), machine model (per JESD22 A115) and charged device model (per JESD22 C101).

Characteristic Curves

Spectral Power Distribution Characteristics

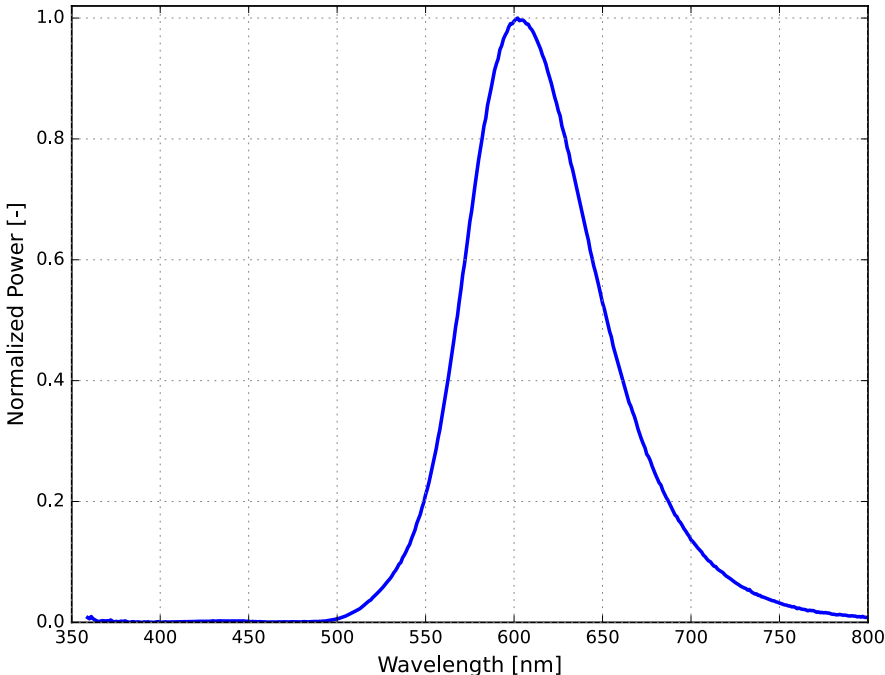

Figure 1. Typical normalized power vs. wavelength for LUXEON Versat 2020 PCA 150 at 20 ms MP, 150 mA, $T_c = 25\text{ }^\circ\text{C}$

Light Output Characteristics

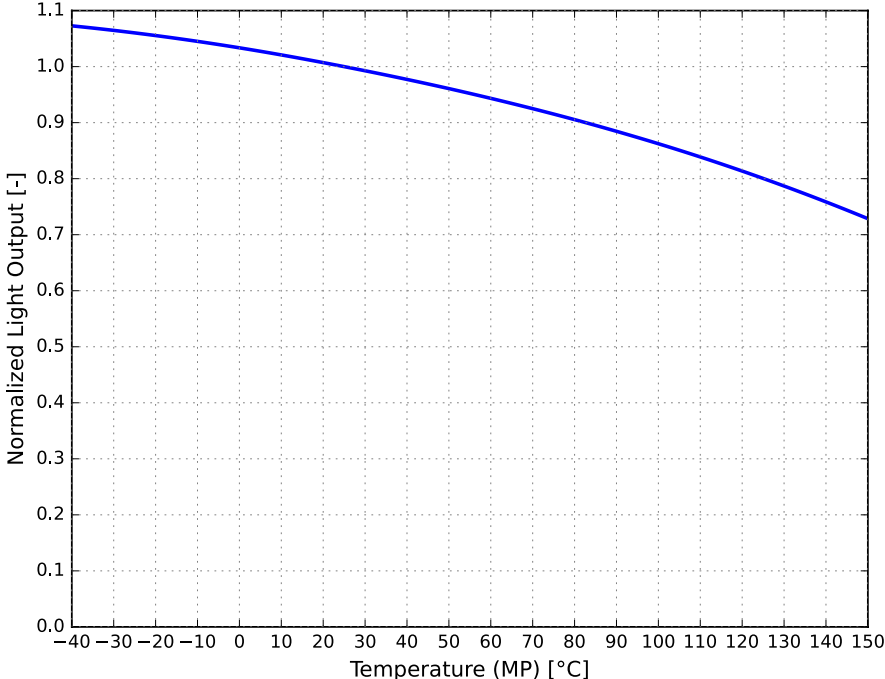

Figure 2. Typical normalized light output vs. case temperature for LUXEON Versat 2020 PCA 150 at 20 ms MP, 150 mA

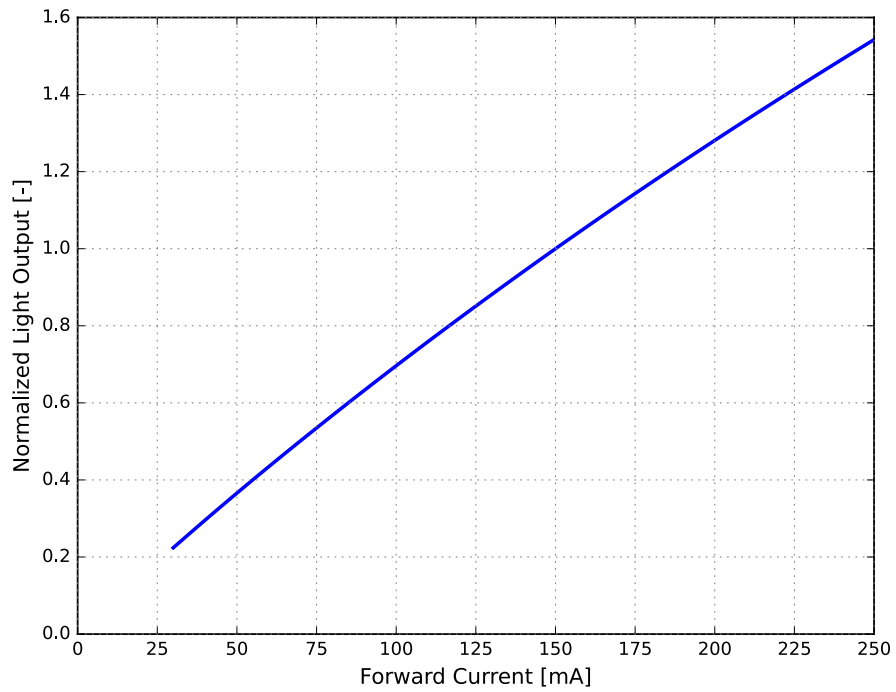

Figure 3. Typical normalized light output vs. forward current for LUXEON Versat 2020 PCA 150 at $T_c = 25\text{ }^\circ\text{C}$

Forward Current and Forward Voltage Characteristics

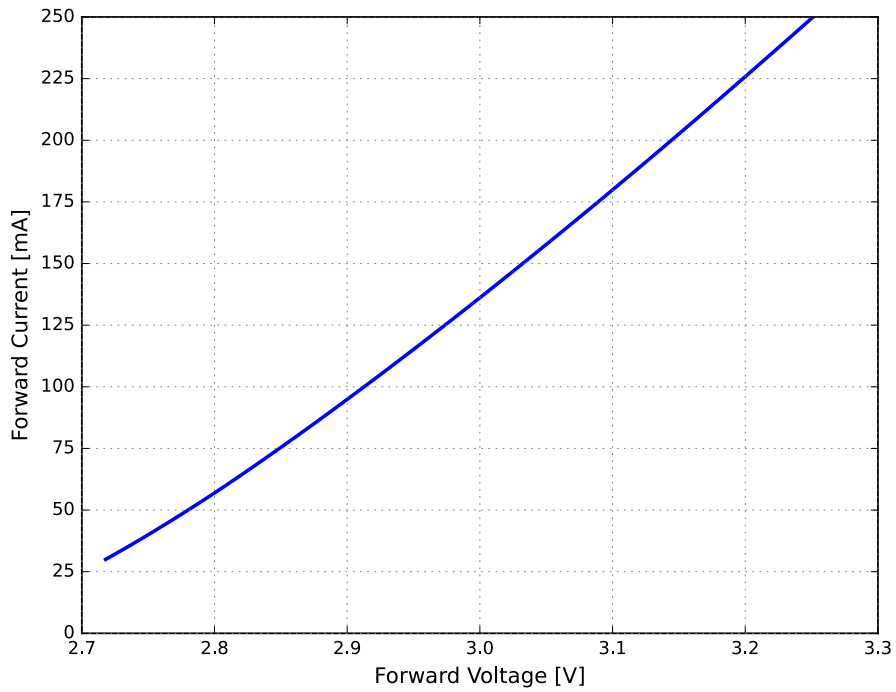

Figure 4. Typical forward current vs. forward voltage for LUXEON Versat 2020 PCA 150 at $T_c = 25\text{ }^\circ\text{C}$

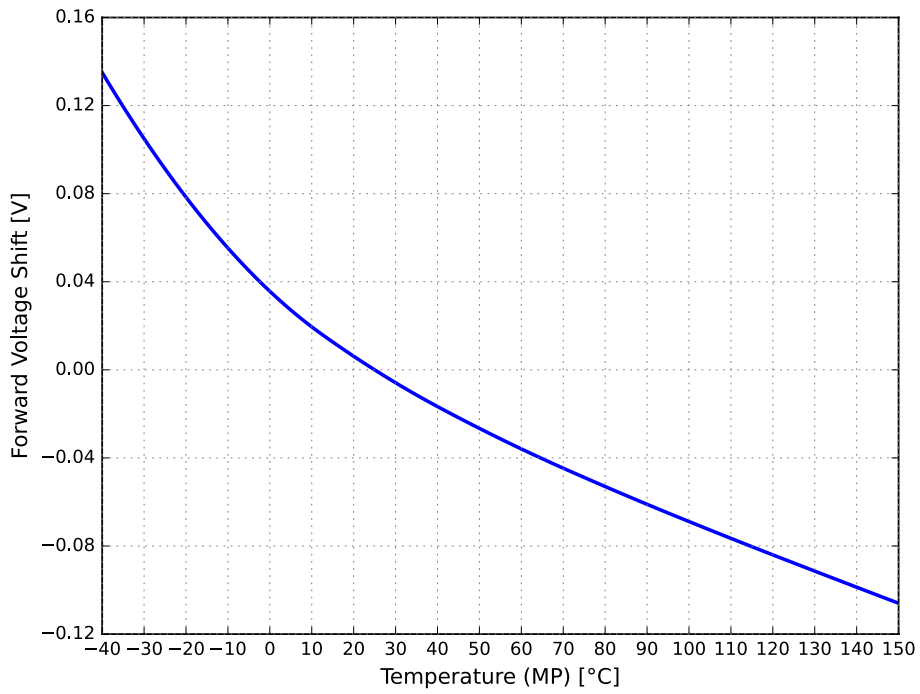

Figure 5. Typical forward voltage shift vs. case temperature for LUXEON Versat 2020 PCA 150

Color Shift Characteristics

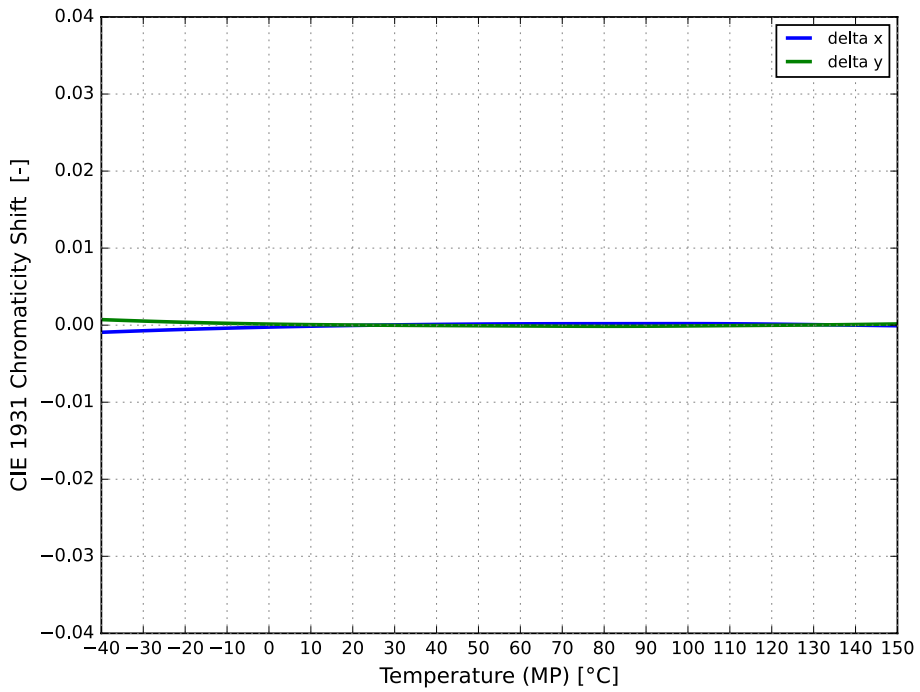

Figure 6. Typical color shift in CIE 1931 x and y coordinates for LUXEON Versat 2020 PCA 150 at 20 ms MP, 150 mA

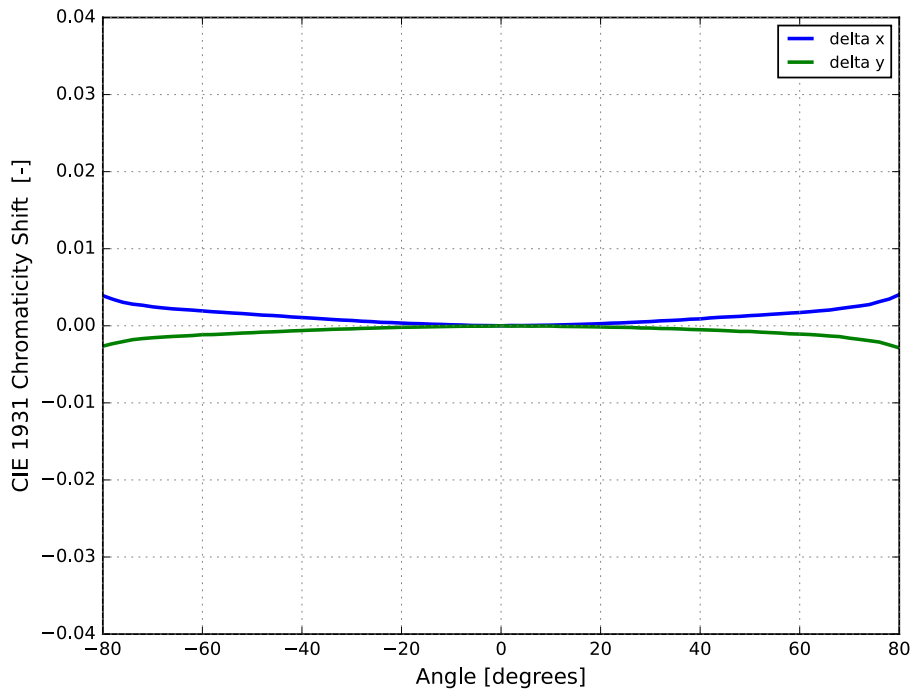

Figure 7. Typical color shift in CIE 1931 x and y coordinates over angle for LUXEON Versat 2020 PCA 150 at 20 ms MP, 150 mA

Radiation Pattern Characteristics

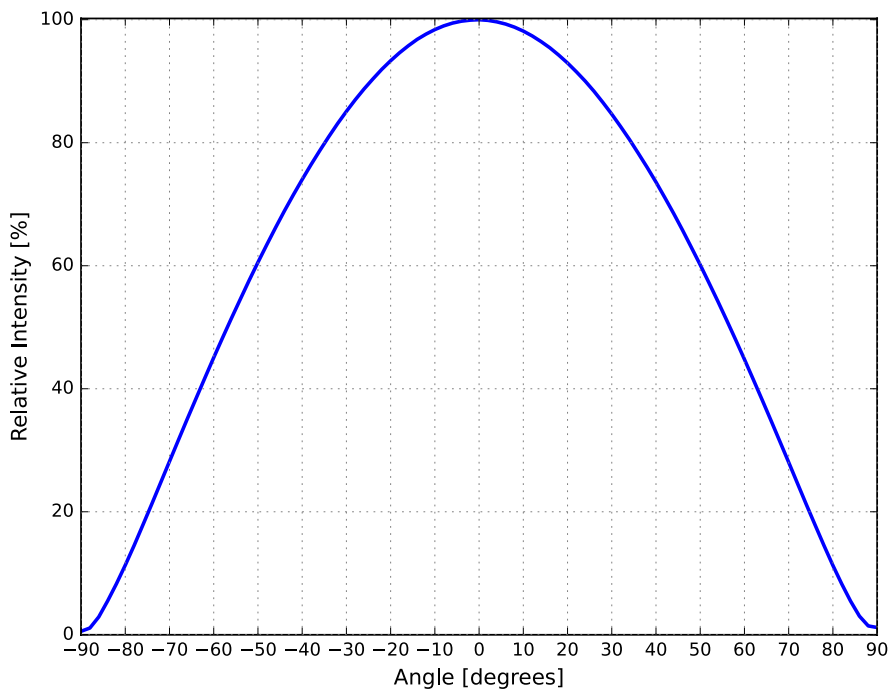

Figure 8. Typical radiation pattern for LUXEON Versat 2020 PCA 150 at 20 ms MP, 150 mA, $T_c = 25\text{ }^\circ\text{C}$

Operating Limits Characteristics

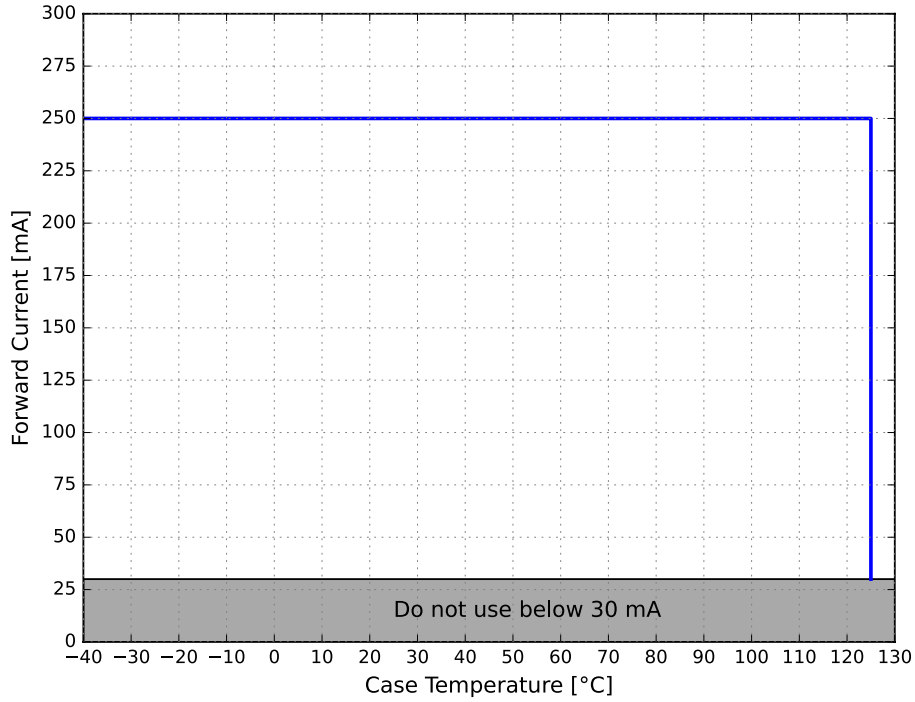

Figure 9. Maximum forward current vs. case temperature for LUXEON Versat 2020 PCA 150

Notes for Figure 9:

- LUXEON Versat LEDs driven at or above maximum LED case temperature may have shorter lifetime. Lumileds does not guarantee reliability of the board interconnect e.g. solder joint cracks caused by thermal mismatch.

Permissible Pulse Handling Characteristics

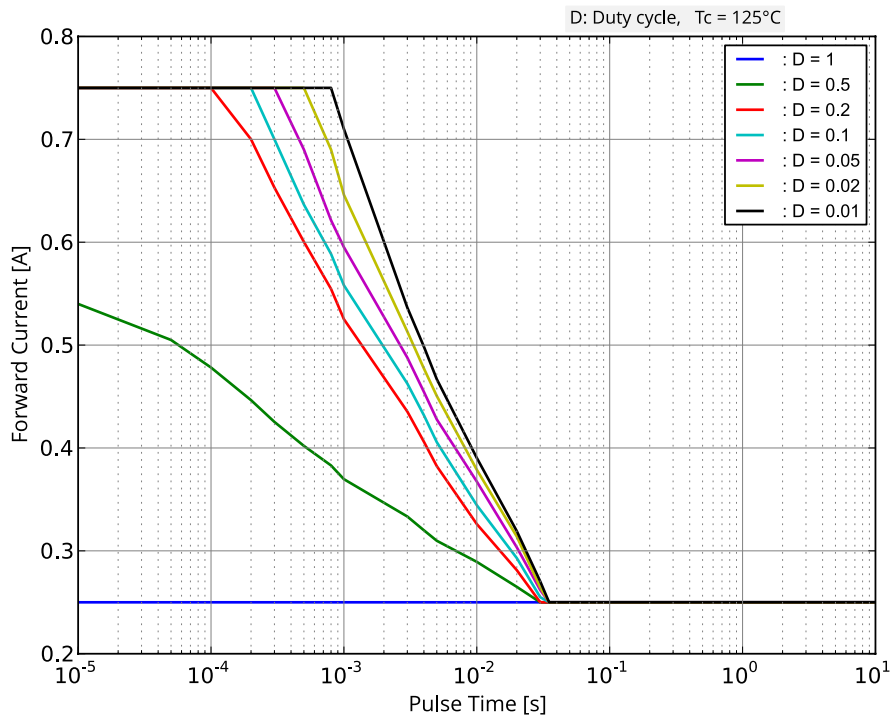

Figure 10. Permissible pulse handling capability for LUXEON Versat 2020 PCA 150

Product Bin and Labeling Definitions

Designing with LUXEON Versat 2020 PCA 150

Flux bins supportable for car programs depend on product color and program start-of-production and end-of-production dates. Flux roadmaps by year and product color are maintained and available from the sales representative. Please contact a local sales representative to request the flux bin range with best supportability for program timing.

Decoding Product Bin Labeling

In the manufacturing of semiconductor products, there are variations in performance around the average values given in the technical datasheets. For this reason, Lumileds bins the LED components for luminous flux or radiometric power, color point, peak or dominant wavelength and forward voltage

LUXEON Versat 2020 PCA 150 LEDs are labeled using a 3-digit alphanumeric CAT code following the format below:

A B C

Where:

- A** – designates luminous flux bin (example: C = 36 lumens to 40 lumens)
- B** – designates color code (A, B)
- C** – designates forward voltage bin (example: B = 2.94 V to 3.20 V)

Therefore, a LUXEON Versat 2020 PCA 150 with a lumen range of 36 to 40, color code of A and a forward voltage range of 2.94 to 3.20 has the following CAT code:

C A B

Luminous Flux Bins

Table 6 lists the standard luminous flux bins for LUXEON Versat 2020 PCA 150 emitters. Product availability in a particular bin varies by color and platform start of production date. Contact local sales representative for best supportability of programs.

Table 5. Luminous flux bins for LUXEON Versat 2020 PCA 150, $T_c = 25\text{ }^\circ\text{C}$

BIN	LUMINOUS FLUX ⁽¹⁾ (lm)	
	MINIMUM	MAXIMUM
A	30	33
B	33	36
C	36	40
D	40	44
E	44	48
F	48	53

Notes for Table 5:

1. Lumileds maintains a tolerance of $\pm 10\%$ on luminous flux measurements.

Color Codes

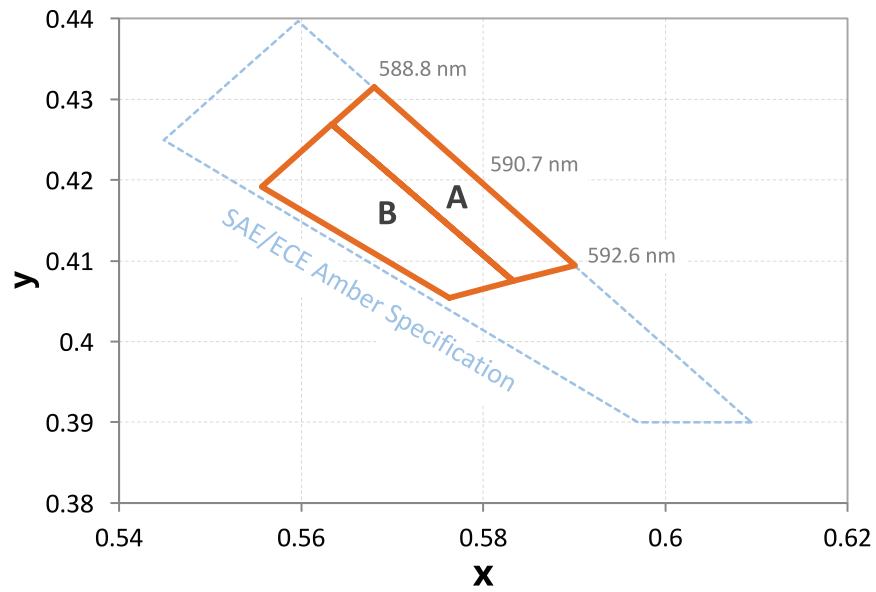

Figure 11. Color bin structure in CIE 1931 color space for LUXEON Versat 2020 PCA 150

Table 6. Color code definitions for LUXEON Versat 2020 PCA 150.

CODE	x	y
A	0.5680	0.4315
	0.5634	0.4269
	0.5833	0.4075
	0.5901	0.4094
B	0.5763	0.4054
	0.5833	0.4075
	0.5634	0.4269
	0.5557	0.4192

Notes for Table 6:

1. Lumileds maintains a tolerance of ± 0.005 on x and y coordinates in the CIE 1931 color space.

Forward Voltage Bins

Table 7. Forward voltage bin definitions for LUXEON Versat 2020 PCA 150

BIN ^[1]	FORWARD VOLTAGE ^[2] (V _f)	
	MINIMUM	MAXIMUM
A	2.70	2.94
B	2.94	3.20
C	3.20	3.49

Notes for Table 7:

1. Although several bins are outlined, product availability in a particular bin varies by production run and by product performance.
2. Lumileds maintains a tolerance of ±0.06V on forward voltage measurements.

Mechanical Dimensions

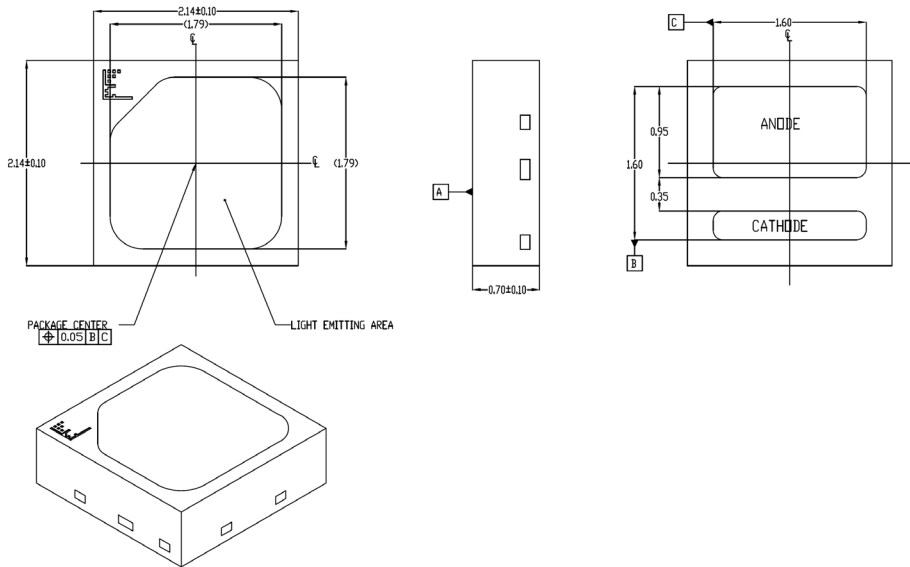

Figure 12. Mechanical dimensions for LUXEON Versat 2020 PCA 150

Notes for Figure 12:

1. Drawings are not to scale.
2. All dimensions are in millimeters.

JEDEC Moisture Sensitivity

Table 8. Moisture sensitivity levels for LUXEON Versat 2020 PCA 150

LEVEL	FLOOR LIFE		STANDARD SOAK REQUIREMENT	
	TIME	CONDITIONS	TIME	CONDITIONS
2	1 Year	≤30°C / 60% RH	168 Hours +5 / -0	85°C / 60% RH

Packaging Information

Pocket Tape Dimensions

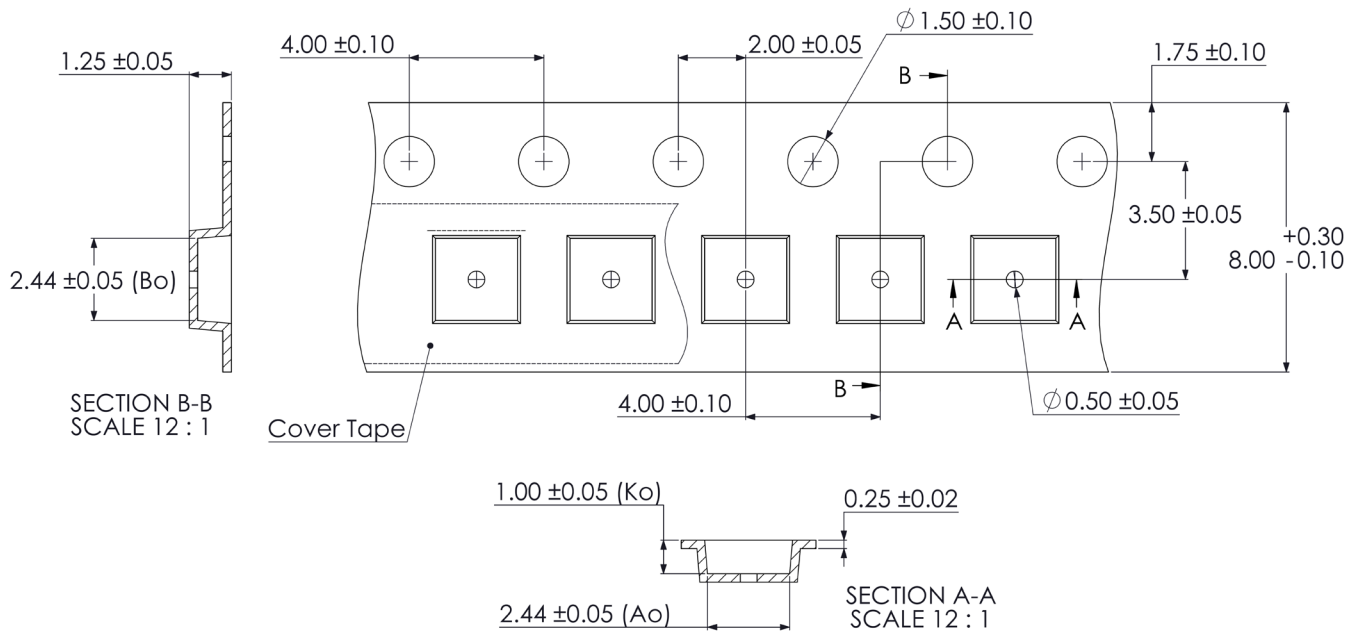

Figure 13. Pocket tape dimensions for LUXEON Versat 2020 PCA 150

Notes for Figure 13:

1. Drawings are not to scale.
2. All dimensions are in millimeters.
3. Ao is the width of pocket, Ko is the depth of pocket, and Bo is the height of pocket.

Reel Dimensions

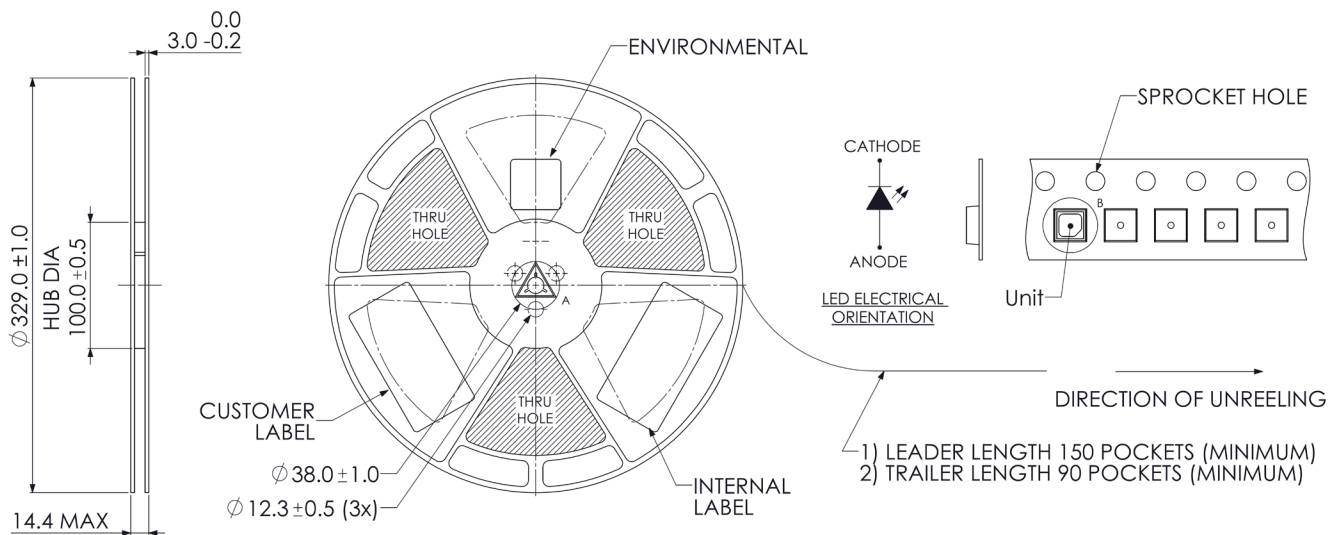

Figure 14. Reel dimensions for LUXEON Versat 2020 PCA 150

Notes for Figure 14:

1. Drawings are not to scale.
2. All dimensions are in millimeters.

Product Labelling

LUXEON Versat 2020 LEDs are packaged in moisture barrier bags on reels. Both moisture barrier bag and reels have printed information providing part numbers with CAT codes that indicate luminous flux bin, color bins and forward voltage bins.

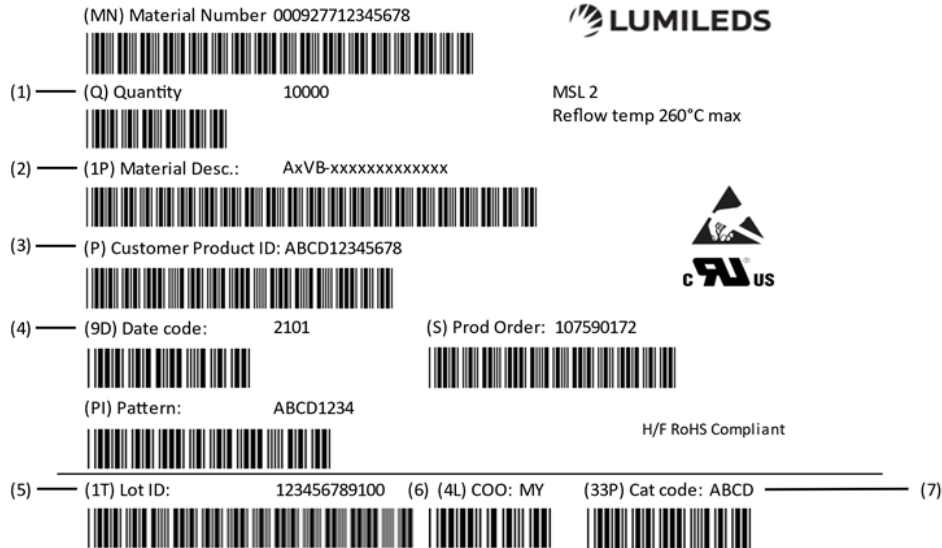

Figure 15. Example of a reel label LUXEON Versat 2020 CW 150

Notes for Figure 15:

Field labels not described are for Lumileds internal use only.

1. Total number of LED emitters in a shipment box.
2. Lumileds part number
3. Customer part number for custom requests only.
4. LED test date in YYWW format.
5. Unique product lot identification number. This number is required for traceability purposes.
6. Country code of origin of manufacturing of part (e.g. MY for Malaysia, CN for China) according to ISO 3166-1 alpha-2 document.
7. Product bin n-digit alphanumeric CAT code.

About Lumileds

Companies developing automotive, mobile, IoT and illumination lighting applications need a partner who can collaborate with them to push the boundaries of light. With over 100 years of inventions and industry firsts, Lumileds is a global lighting solutions company that helps customers around the world deliver differentiated solutions to gain and maintain a competitive edge. As the inventor of Xenon technology, a pioneer in halogen lighting and the leader in high performance LEDs, Lumileds builds innovation, quality and reliability into its technology, products and every customer engagement. Together with its customers, Lumileds is making the world safer, better and more beautiful—with light.

To learn more about our lighting solutions, visit lumileds.com.



©2021 Lumileds Holding B.V. All rights reserved.
LUXEON is a registered trademark of the Lumileds Holding B.V. in the United States and other countries.
lumileds.com

Neither Lumileds Holding B.V. nor its affiliates shall be liable for any kind of loss of data or any other damages, direct, indirect or consequential, resulting from the use of the provided information and data. Although Lumileds Holding B.V. and/or its affiliates have attempted to provide the most accurate information and data, the materials and services information and data are provided "as is," and neither Lumileds Holding B.V. nor its affiliates warrants or guarantees the contents and correctness of the provided information and data. Lumileds Holding B.V. and its affiliates reserve the right to make changes without notice. You as user agree to this disclaimer and user agreement with the download or use of the provided materials, information and data. A listing of Lumileds product/patent coverage may be accessed at lumileds.com/patents.