

# LUXEON CoB Core Range PW Gen 5

Engineered for vibrant colors

LUXEON CoB Core Range PW was built for applications that need the highest quality of light combined with market leading performances. Its beautiful color transforms areas into vibrant spaces. Above all, LUXEON CoB Core Range PW has a robust, long life span and fits easily into luminaire designs.



## FEATURES AND BENEFITS

- High efficacy and superior color quality at lower energy consumption
- Various LES sizes and flux output that fit different applications and requirements
- Best in class thermal resistance enabling the use of smaller heatsinks and prolonged product life span
- Supported by a comprehensive optical, mechanical, and electrical ecosystem

## PRIMARY APPLICATIONS

- Spotlights
- Track Lights
- Downlights
- Low Bay

# Table of Contents

<b>General Product Information</b> .....	<b>2</b>
Product Test Conditions .....	2
Part Number Nomenclature .....	2
Lumen Maintenance .....	2
<b>Environmental Compliance</b> .....	<b>3</b>
Use Limitations .....	3
<b>Performance Characteristics</b> .....	<b>4</b>
Product Selection Guide .....	4
Optical Characteristics .....	5
Electrical and Thermal Characteristics .....	5
<b>Absolute Maximum Ratings</b> .....	<b>5</b>
<b>Characteristic Curves</b> .....	<b>6</b>
Spectral Power Distribution Characteristics .....	6
Light Output Characteristics .....	7
Forward Current Characteristics .....	12
Radiation Pattern Characteristics .....	16
<b>Color Bin Definitions</b> .....	<b>17</b>
<b>Mechanical Dimensions</b> .....	<b>18</b>
<b>Packaging and Labeling Information</b> .....	<b>19</b>
Tube .....	19
Inner Box .....	21
Outer Box .....	22

# General Product Information

## Product Test Conditions

LUXEON CoB Core Range PW LEDs are tested and binned with a DC drive current specified below at a junction temperature,  $T_j$ , of 85°C:

200mA	-	L2C5-AABB1202H06PG
200mA	-	L2C5-AABB1202H09PG
300mA	-	L2C5-AABB1203H09PG
400mA	-	L2C5-AABB1204H09PG
600mA	-	L2C5-AABB1205H13PG
900mA	-	L2C5-AABB1208H15PG
900mA	-	L2C5-AABB1210H15PG
1200mA	-	L2C5-AABB1211H19PG

## Part Number Nomenclature

Part numbers for LUXEON CoB Core Range PW follow the convention below:

L 2 C 5 - **A A B B C C C C D E E F G**

Where:

- A A** - designates nominal CCT (30=3000K, 35=3500K, 40=4000K)
- B B** - designates minimum CRI (80=80CRI, 90=90CRI)
- C C C C** - designates product configuration (example: 1205, 1208, 1210, 1211)
- D** - designates options for product specification
- E E** - designates light emitting surface (LES) size (13=13mm, 15=15mm, 19=19mm)
- F** - designates options for product specification
- G** - designates SDCM (2=2-step MacAdam, 0=3-step MacAdam)

Therefore, the following part number is used for a LUXEON Core Range CoB PW 1208, Gen 5, 3000K 90CRI, 2 SDCM, with a 15mm LES:

L 2 C 5 - **3 0 9 0 1 2 0 8 H 1 5 P 2**

## Lumen Maintenance

Please contact your local Sales Representative or Lumileds Technical Solutions Manager for more information about the long-term performance of this product.

## Environmental Compliance

Lumileds LLC is committed to providing environmentally friendly products to the solid-state lighting market. LUXEON CoB Core Range PW is compliant to the European Union directives on the restriction of hazardous substances in electronic equipment, namely the ROHS Directive 2011/65/EU including amendments 2015/863/EU & 2017/2102/EU and REACH Regulation (EC) 1907/2006. Lumileds LLC will not intentionally add the following restricted materials to its products: lead, mercury, cadmium, hexavalent chromium, polybrominated biphenyls (PBB) or polybrominated diphenyl ethers (PBDE).

# Performance Characteristics

## Product Selection Guide

Table 1. Product performance of LUXEON CoB Core Range PW at specified test current,  $T_j=85^\circ\text{C}$ .

LES <sup>[1]</sup> (mm)	NOMINAL CCT	MINIMUM CRI <sup>[2, 3, 4]</sup>	LUMINOUS FLUX <sup>[2]</sup> (lm)		TYPICAL LUMINOUS EFFICACY (lm/W)	TEST CURRENT (mA)	ENERGY EFFICIENCY CLASS <sup>[5]</sup>	PART NUMBER <sup>[6]</sup>
			MINIMUM	TYPICAL				
6	3000K	80	952	1058	156	200	D	L2C5-30801202H06Px
6	3000K	90	929	1032	152	200	D	L2C5-30901202H06Px
6	3500K	90	953	1058	156	200	D	L2C5-35901202H06Px
6	4000K	90	974	1082	160	200	D	L2C5-40901202H06Px
9	3000K	80	977	1086	160	200	D	L2C5-30801202H09Px
9	3000K	90	957	1063	157	200	D	L2C5-30901202H09Px
9	3500K	90	981	1090	161	200	D	L2C5-35901202H09Px
9	4000K	90	1003	1114	164	200	D	L2C5-40901202H09Px
9	3000K	80	1438	1598	157	300	D	L2C5-30801203H09Px
9	3000K	90	1384	1537	151	300	D	L2C5-30901203H09Px
9	3500K	90	1419	1577	155	300	D	L2C5-35901203H09Px
9	4000K	90	1451	1612	159	300	D	L2C5-40901203H09Px
9	3000K	80	1924	2138	158	400	D	L2C5-30801204H09Px
9	3000K	90	1839	2043	151	400	D	L2C5-30901204H09Px
9	3500K	90	1886	2096	155	400	D	L2C5-35901204H09Px
9	4000K	90	1928	2142	158	400	D	L2C5-40901204H09Px
13	3000K	80	2821	3134	151	600	D	L2C5-30801205H13Px
13	3000K	90	2835	3150	152	600	D	L2C5-30901205H13Px
13	3500K	90	2901	3223	156	600	D	L2C5-35901205H13Px
13	4000K	90	2963	3292	159	600	D	L2C5-40901205H13Px
15	3000K	80	4320	4800	156	900	D	L2C5-30801208H15Px
15	3000K	90	4253	4725	154	900	D	L2C5-30901208H15Px
15	3500K	90	4285	4762	155	900	D	L2C5-35901208H15Px
15	4000K	90	4495	4994	162	900	D	L2C5-40901208H15Px
15	3000K	80	4357	4841	160	900	D	L2C5-30801210H15Px
15	3000K	90	4221	4690	155	900	D	L2C5-30901210H15Px
15	3500K	90	4377	4863	161	900	D	L2C5-35901210H15Px
15	4000K	90	4482	4980	165	900	D	L2C5-40901210H15Px
19	3000K	80	5778	6420	156	1200	D	L2C5-30801211H19Px
19	3000K	90	5688	6320	154	1200	D	L2C5-30901211H19Px
19	3500K	90	5766	6407	156	1200	D	L2C5-35901211H19Px
19	4000K	90	5905	6562	160	1200	D	L2C5-40901211H19Px

**Notes for Table 1:**

1. Light Emitting Surface (LES) is the inner diameter (phosphor area) inside the dam.
2. Lumileds maintains a tolerance of  $\pm 2$  on CRI and  $\pm 6.5\%$  on luminous flux measurements.
3. Typical CRI is approximately 2 points higher than the minimum CRI specified, but this is not guaranteed.
4. R9 value of 90CRI products is  $>50$ .
5. Energy efficiency class as specified in Commission Delegated Regulation (EU) 2019/2015. The available range of energy efficiency classes is A-G.
6. Part number ends with "x" designates SDCM, 2=2-SDCM, 0=3SDCM.

# Optical Characteristics

Table 2. Optical characteristics for LUXEON CoB Core Range PW at specified test current,  $T_j=85^\circ\text{C}$ .

PART NUMBER	TYPICAL TOTAL INCLUDED ANGLE <sup>[1]</sup>	TYPICAL VIEWING ANGLE <sup>[2]</sup>
L2C5-xxxx12xxxxPx	135°	115°

**Notes for Table 2:**

- Total angle at which 90% of total luminous flux is captured.
- Viewing angle is the off axis angle from the LED centerline where the luminous intensity is 1/2 of the peak value.

# Electrical and Thermal Characteristics

Table 3. Electrical and thermal characteristics for LUXEON CoB Core Range PW at specified test current,  $T_j=85^\circ\text{C}$ .

PART NUMBER	FORWARD VOLTAGE <sup>[1]</sup> ( $V_f$ )			TYPICAL TEMPERATURE COEFFICIENT OF FORWARD VOLTAGE <sup>[2]</sup> (mV/°C)	TYPICAL THERMAL RESISTANCE—JUNCTION TO CASE <sup>[3]</sup> (°C/W)
	MINIMUM	TYPICAL	MAXIMUM		
L2C5-xxxx1202H06Px	31.2	33.9	36.6	-16	0.78
L2C5-xxxx1202H09Px	31.2	33.9	36.6	-16	0.78
L2C5-xxxx1203H09Px	31.2	33.9	36.6	-16	0.60
L2C5-xxxx1204H09Px	31.2	33.9	36.6	-16	0.43
L2C5-xxxx1205H13Px	31.7	34.5	37.3	-16	0.26
L2C5-xxxx1208H15Px	31.5	34.2	36.9	-16	0.20
L2C5-xxxx1210H15Px	30.9	33.6	36.3	-16	0.18
L2C5-xxxx1211H19Px	31.5	34.2	36.9	-16	0.16

**Notes for Table 3:**

- Lumileds maintains a tolerance of  $\pm 0.06\text{V}$  on forward voltage measurements.
- Measured between 25°C and 85°C.
- Thermal resistance is measured between junction and the bottom of the LUXEON CoB substrate.

# Absolute Maximum Ratings

Table 4. Absolute maximum ratings for LUXEON CoB Core Range PW.

PARAMETER	MAXIMUM PERFORMANCE
DC Forward Current <sup>[1,2]</sup>	2x test current
LED Junction Temperature <sup>[1]</sup> (DC & Pulse)	125°C
ESD Sensitivity (ANSI/ESDA/JEDEC JS-001-2012)	Class 3B
Operating Case Temperature <sup>[1]</sup>	-40°C to 105°C
LED Storage Temperature	-40°C to 120°C
Reverse Voltage ( $V_{\text{reverse}}$ )	LUXEON LEDs are not designed to be driven in reverse bias

**Notes for Table 4:**

- Proper current derating must be observed to maintain the junction temperature below the maximum allowable junction temperature.
- Residual periodic variations due to power conversion from alternating current (AC) to direct current (DC), also called "ripple," are acceptable if the following conditions are met:
  - The frequency of the ripple current is 100Hz or higher
  - The average current for each cycle does not exceed the maximum allowable DC forward current
  - The maximum amplitude of the ripple does not exceed 20% of the maximum allowable DC forward current.

# Characteristic Curves

## Spectral Power Distribution Characteristics

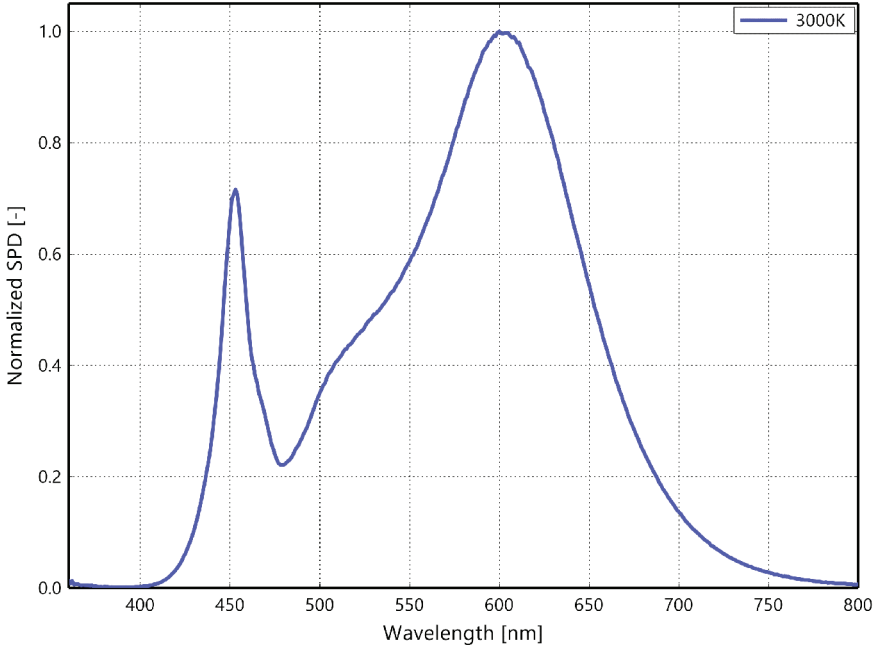

Figure 1a. Typical normalized power vs. wavelength for L2C5-xx80xxxHxxPx at specified test current,  $T_j=85^{\circ}\text{C}$ .

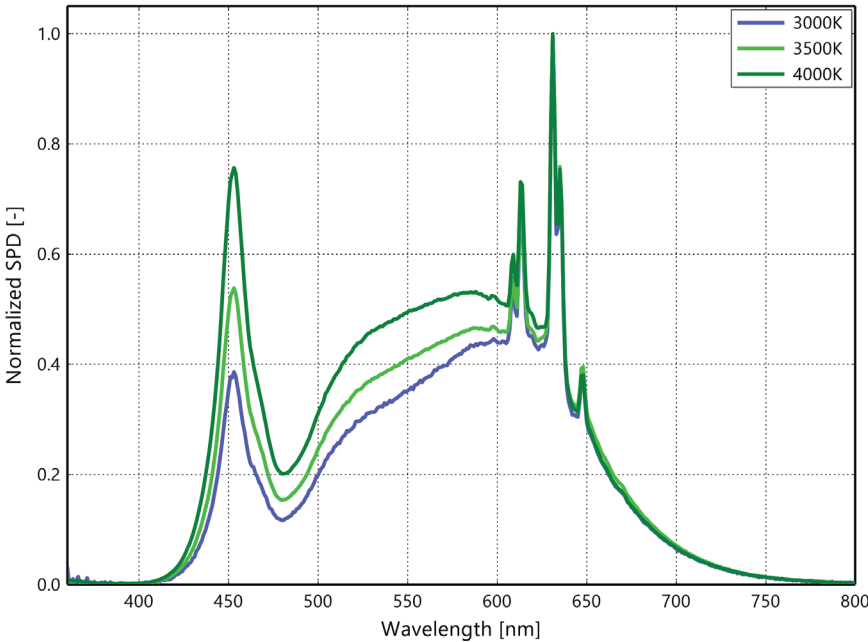

Figure 1b. Typical normalized power vs. wavelength for L2C5-xx90xxxHxxPx at specified test current,  $T_j=85^{\circ}\text{C}$ .

# Light Output Characteristics

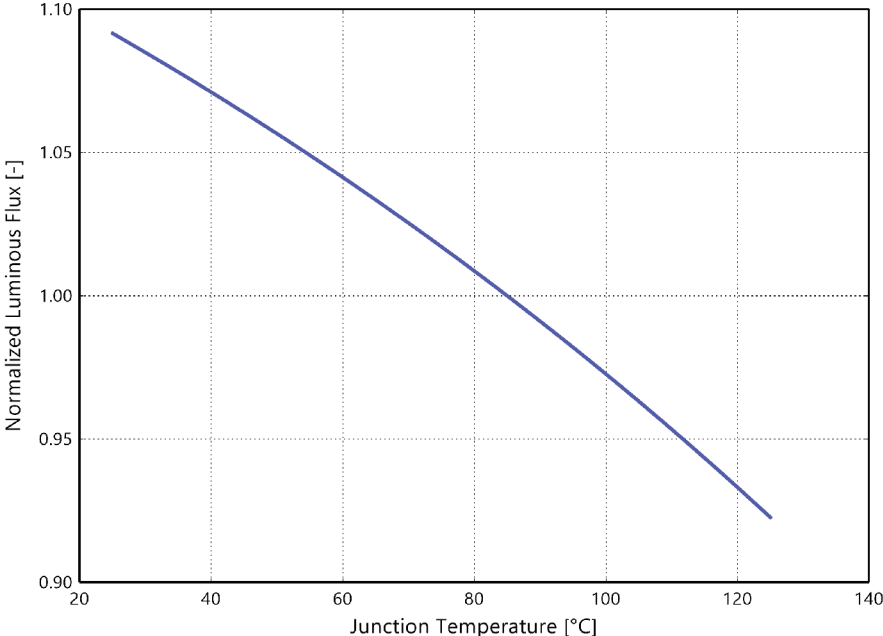

Figure 2. Typical normalized light output vs. junction temperature for L2C5-xxxx12xxxxPx at specified test current.

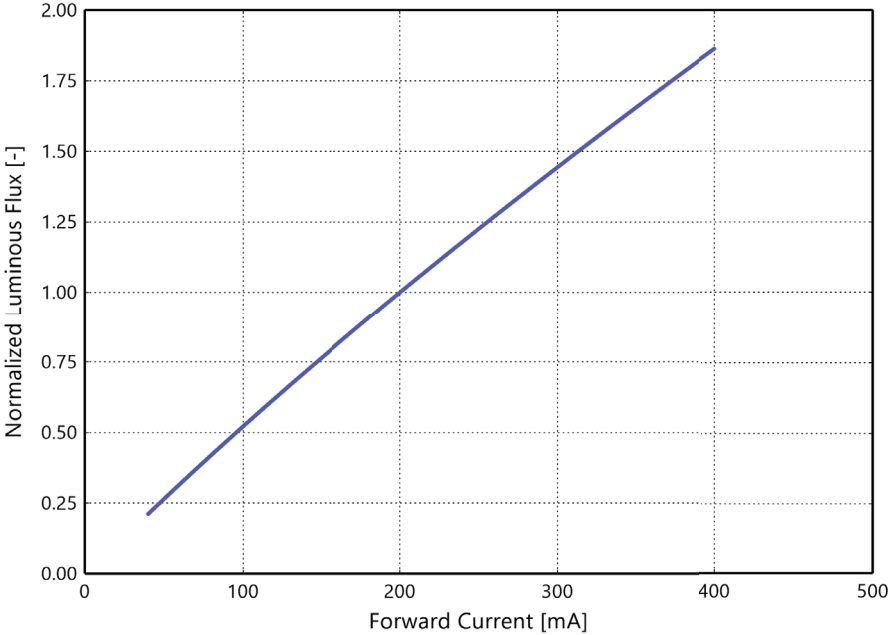

Figure 3a. Typical normalized light output vs. forward current for L2C5-xxxx1202H06Px at  $T_j=85^\circ\text{C}$ .

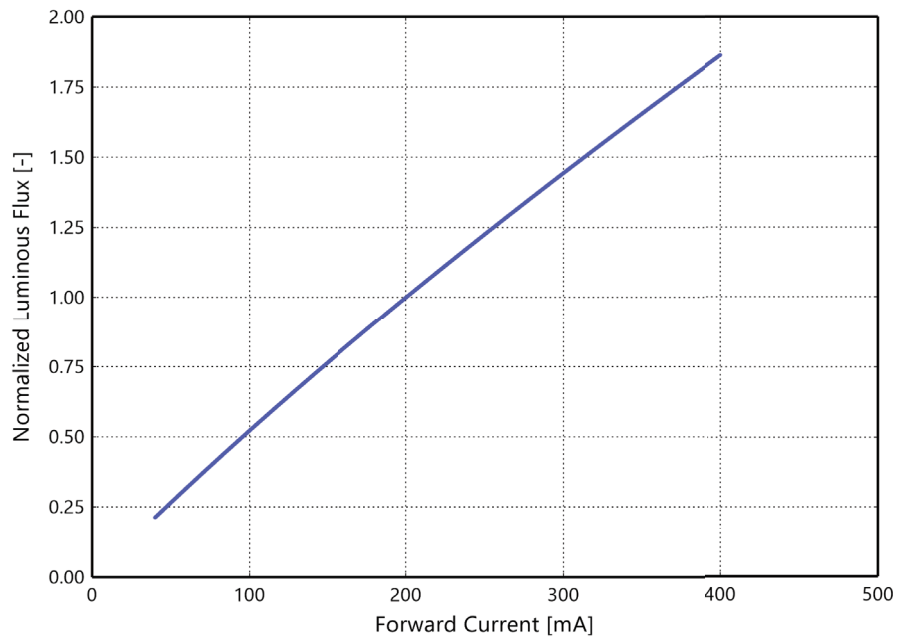

Figure 3b. Typical normalized light output vs. forward current for L2C5-xxxx1202H06Px at  $T_j=85^\circ\text{C}$ .

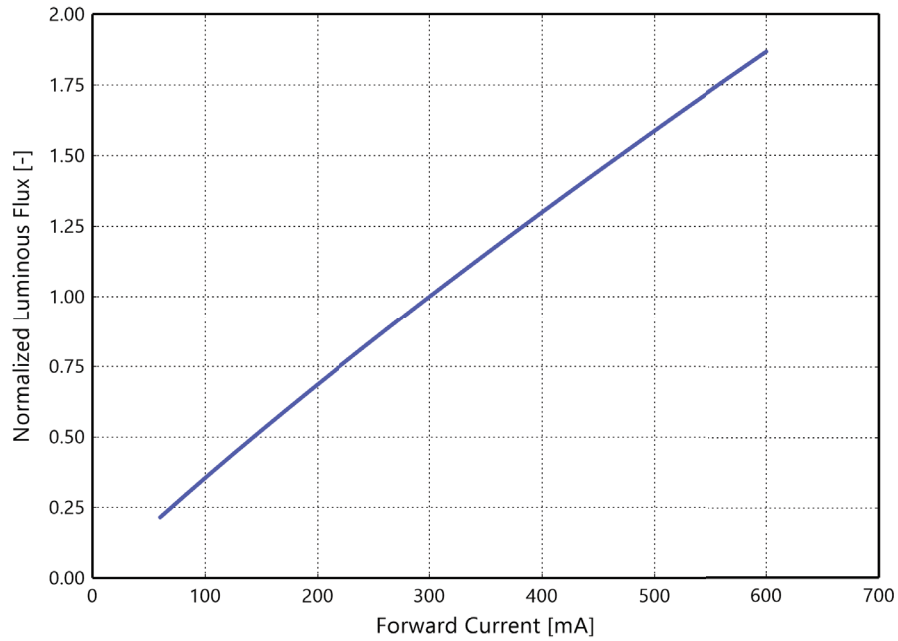

Figure 3c. Typical normalized light output vs. forward current for L2C5-xxxx1203H09Px at  $T_j=85^\circ\text{C}$ .



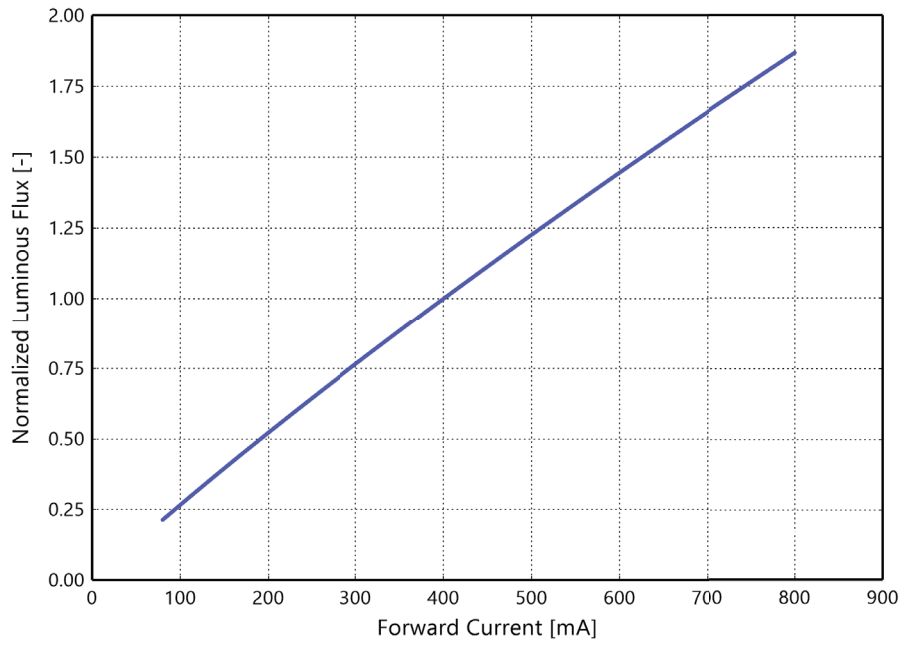

Figure 3d. Typical normalized light output vs. forward current for L2C5-xxxx1204H09Px at  $T_j=85^\circ\text{C}$ .

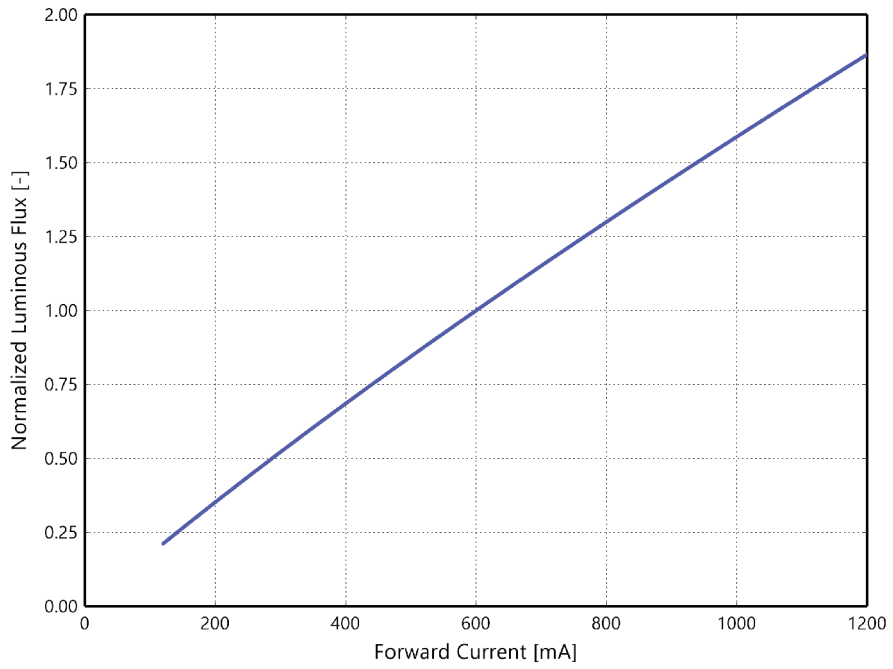

Figure 3e. Typical normalized light output vs. forward current for L2C5-xxxx1205H13Px at  $T_j=85^\circ\text{C}$ .

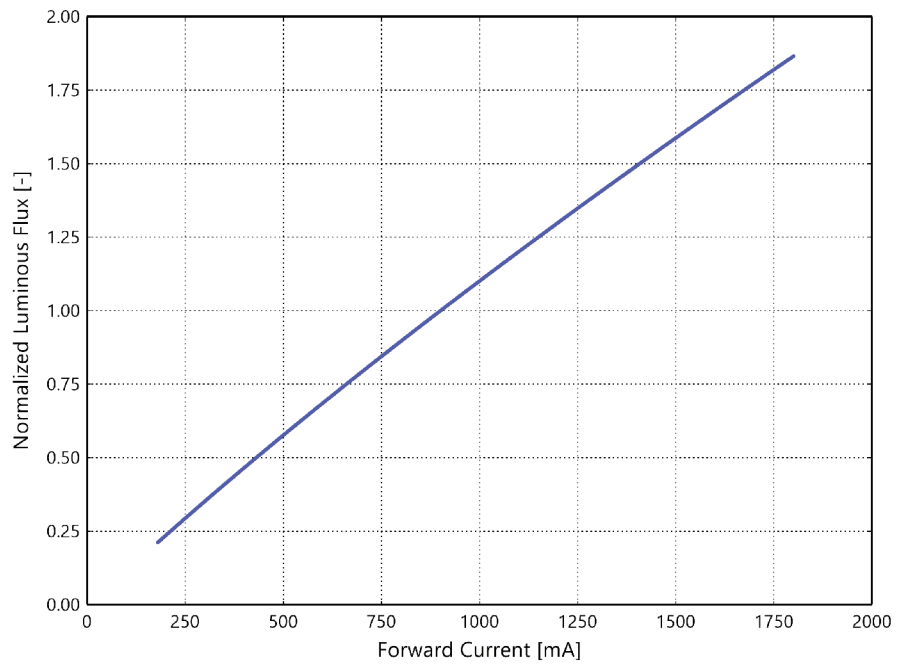

Figure 3f. Typical normalized light output vs. forward current for L2C5-xxxx1208H15Px at  $T_j=85^\circ\text{C}$ .

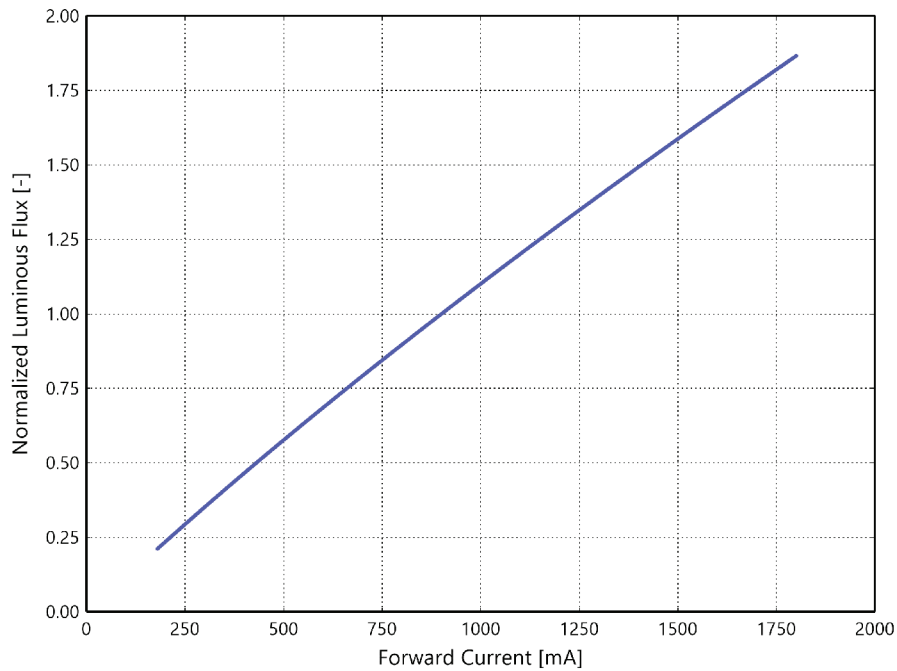

Figure 3g. Typical normalized light output vs. forward current for L2C5-xxxx1210H15Px at  $T_j=85^\circ\text{C}$ .

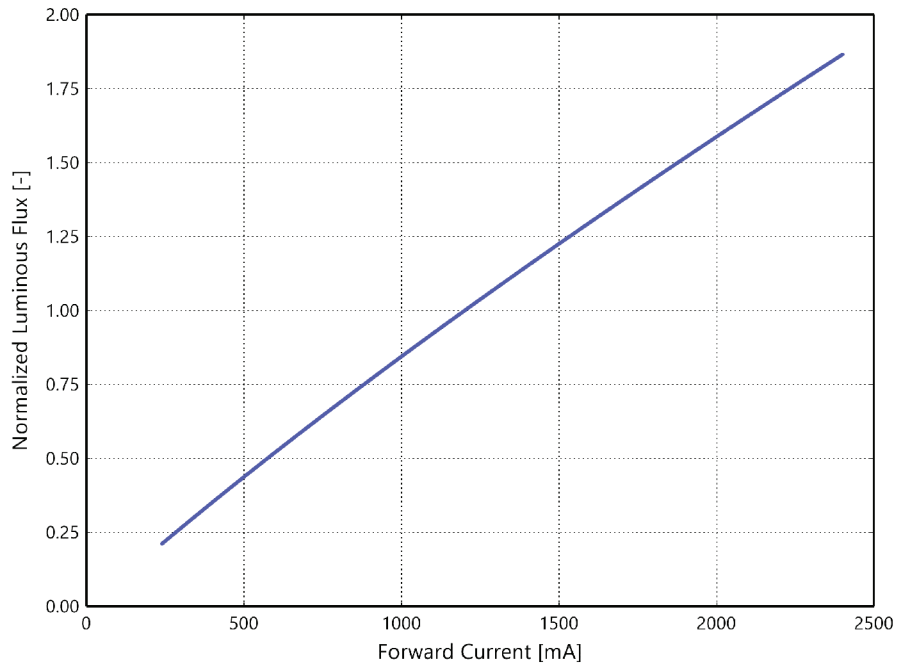

Figure 3h. Typical normalized light output vs. forward current for L2C5-xxxx1211H19Px at  $T_j=85^{\circ}\text{C}$ .

# Forward Current Characteristics

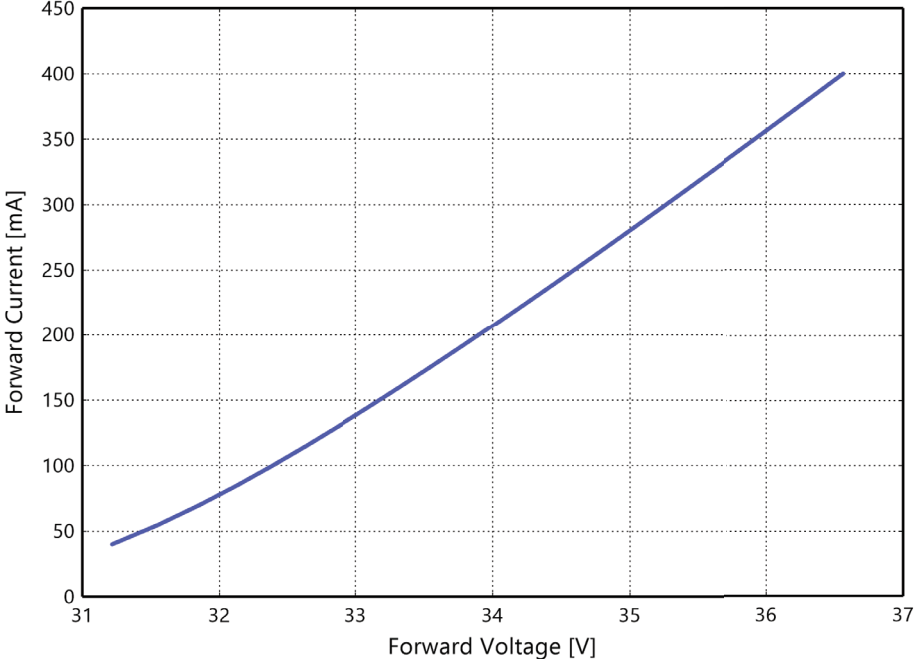

Figure 4a. Typical forward current vs. forward voltage for L2C5-xxxx1202H06Px at  $T_j=85^\circ\text{C}$ .

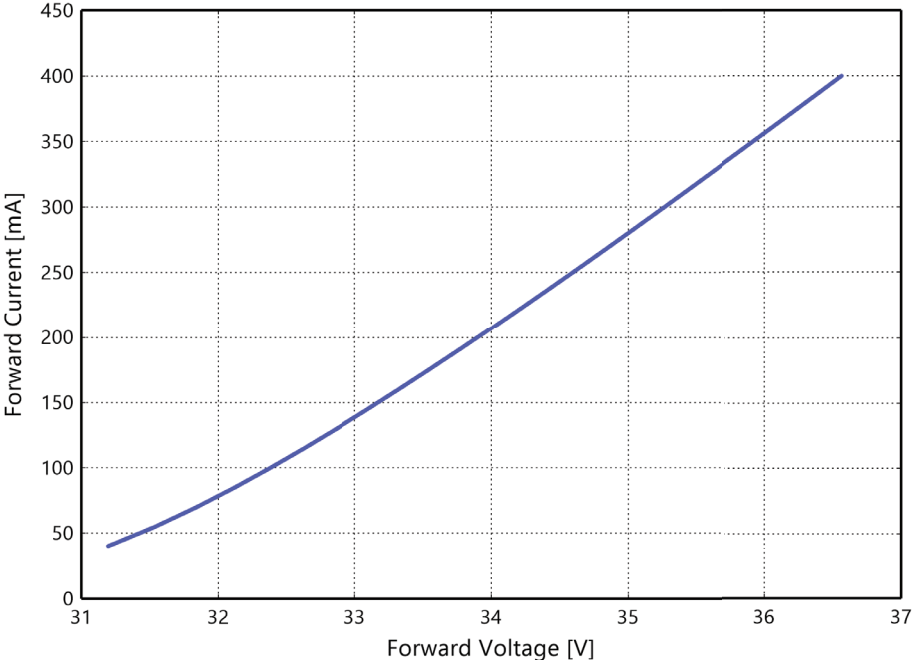

Figure 4b. Typical forward current vs. forward voltage for L2C5-xxxx1202H09Px at  $T_j=85^\circ\text{C}$ .

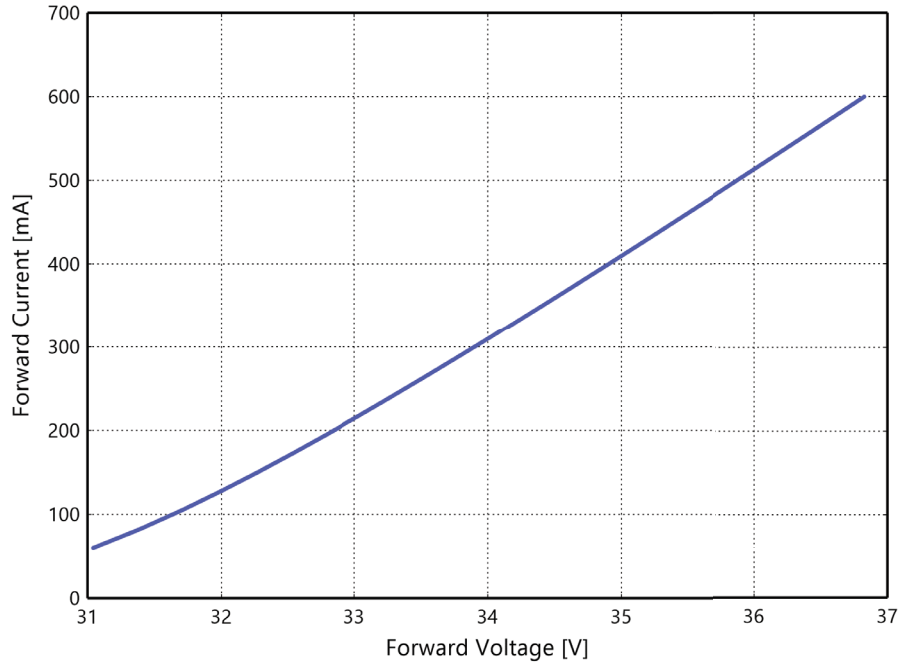

Figure 4c. Typical forward current vs. forward voltage for L2C5-xxxx1203H09Px at  $T_j=85^\circ\text{C}$ .

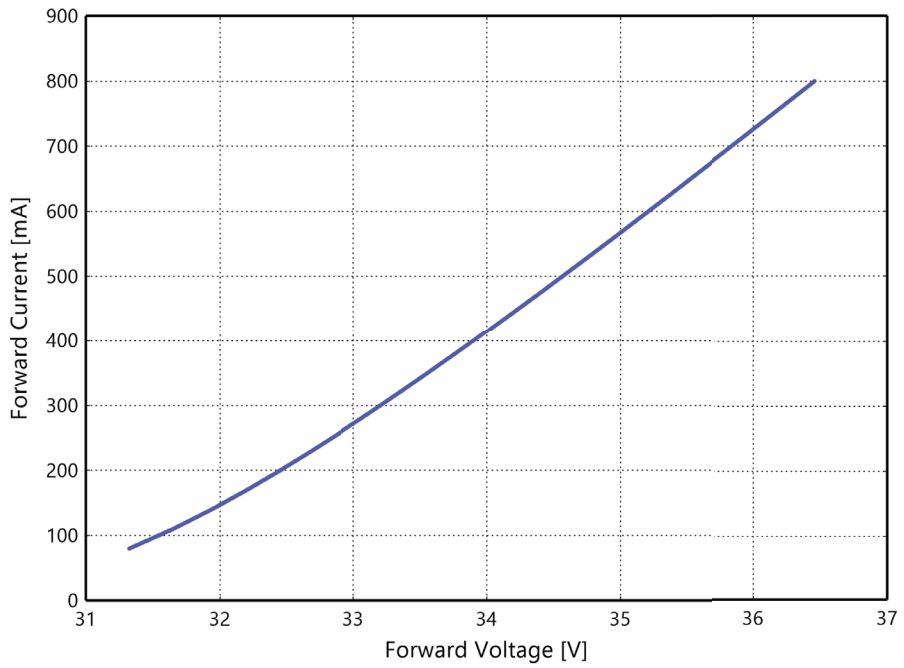

Figure 4d. Typical forward current vs. forward voltage for L2C5-xxxx1204H09Px at  $T_j=85^\circ\text{C}$ .

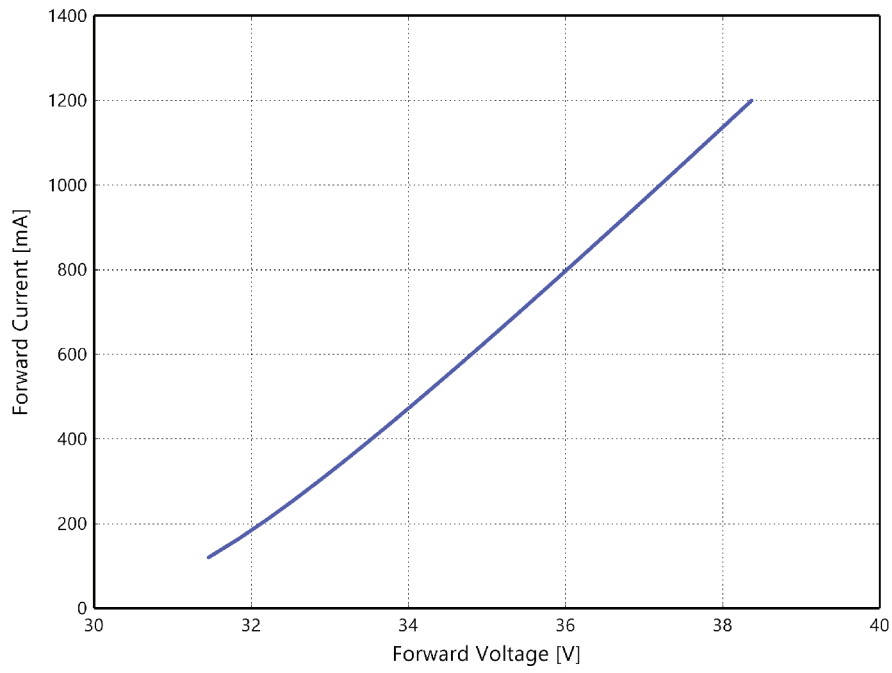

Figure 4e. Typical forward current vs. forward voltage for L2C5-xxxx1205H13Px at  $T_j=85^\circ\text{C}$ .

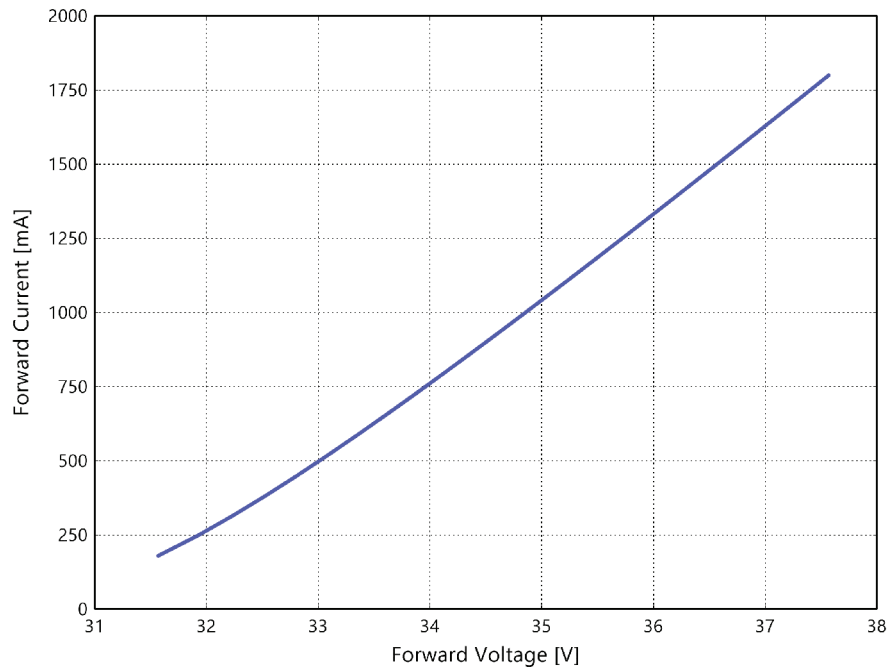

Figure 4f. Typical forward current vs. forward voltage for L2C5-xxxx1208H15Px at  $T_j=85^\circ\text{C}$ .

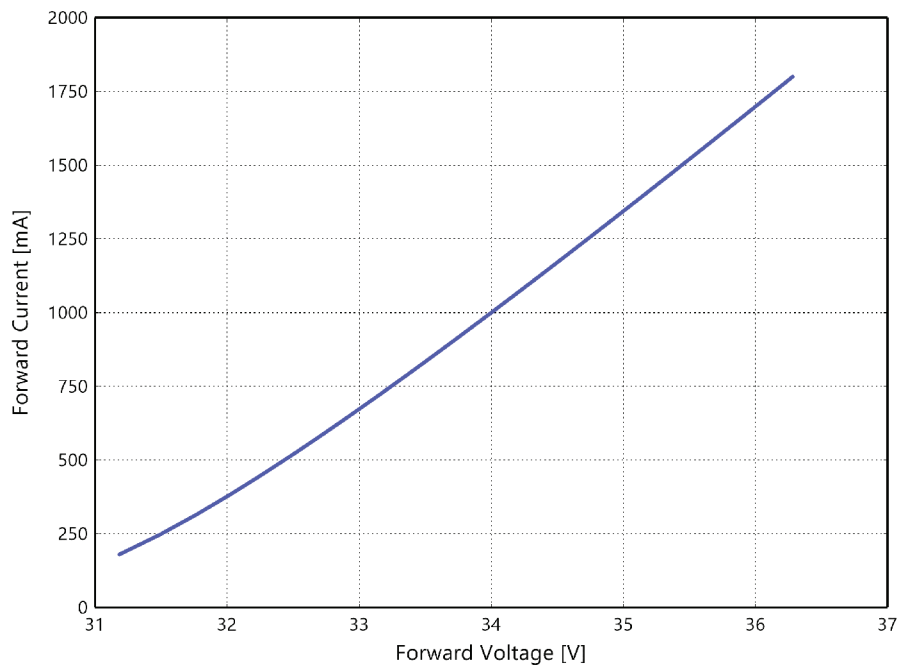

Figure 4g. Typical forward current vs. forward voltage for L2C5-xxxx1210H15Px at  $T_j=85^\circ\text{C}$ .

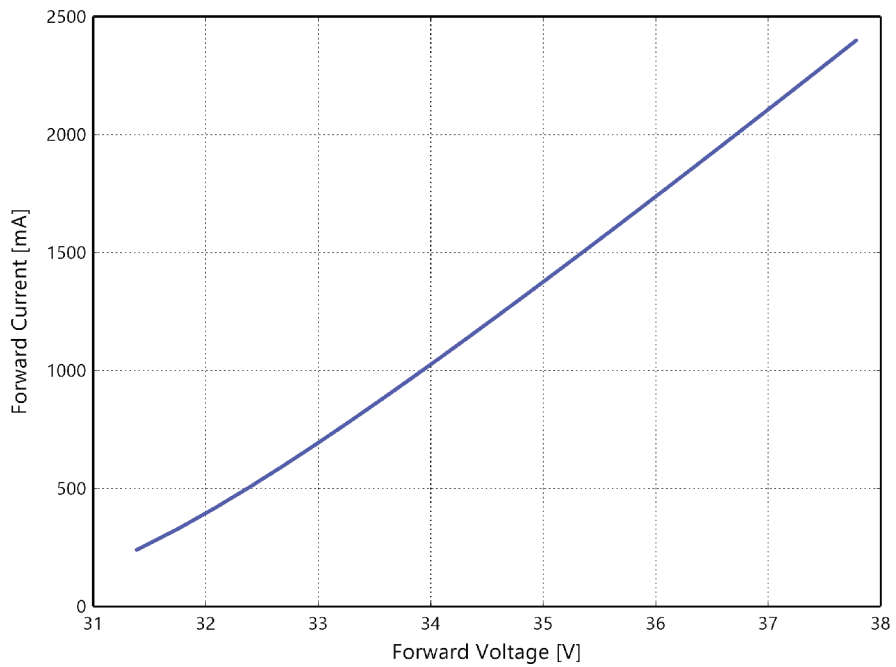

Figure 4h. Typical forward current vs. forward voltage for L2C5-xxxx1211H11Px at  $T_j=85^\circ\text{C}$ .

# Radiation Pattern Characteristics

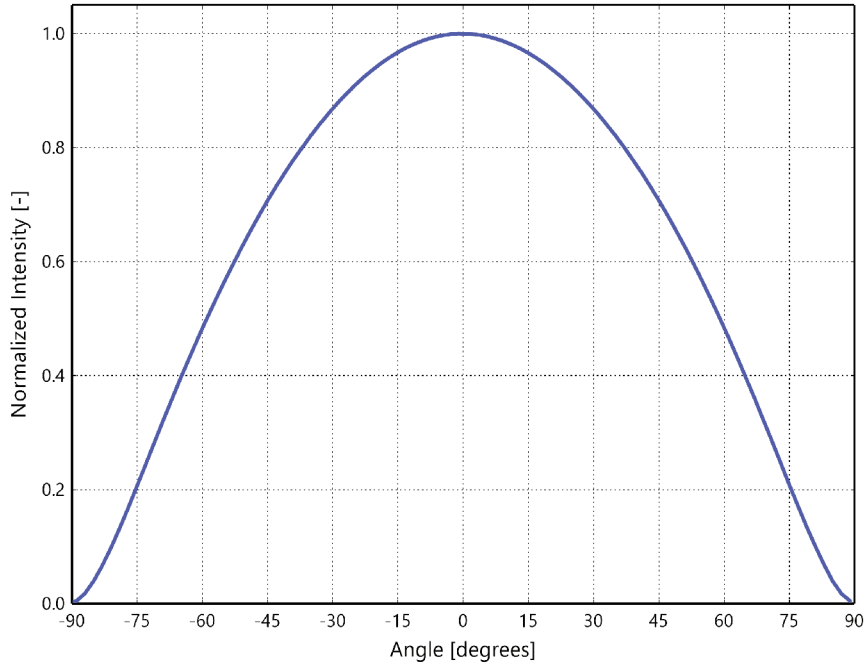

Figure 5. Typical radiation pattern for LUXEON CoB Core Range PW at specified test current,  $T_j=85^{\circ}\text{C}$ .

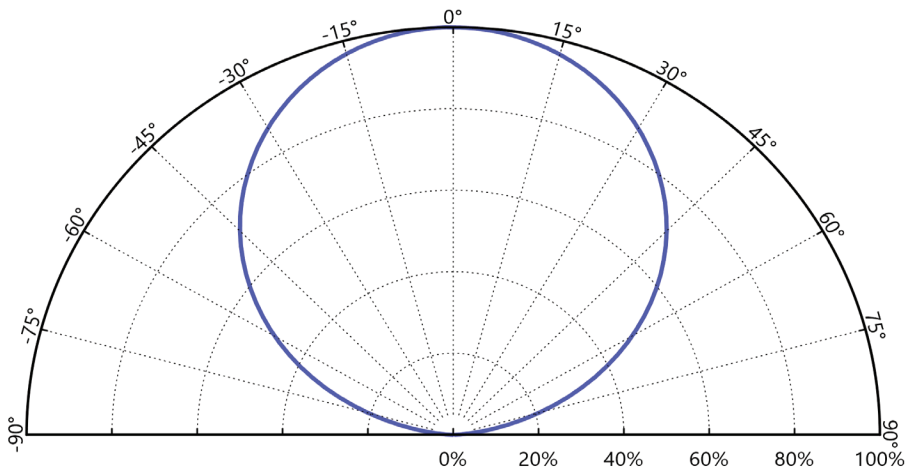

Figure 6. Typical polar radiation pattern for LUXEON CoB Core Range PW at specified test current,  $T_j=85^{\circ}\text{C}$ .



# Color Bin Definitions

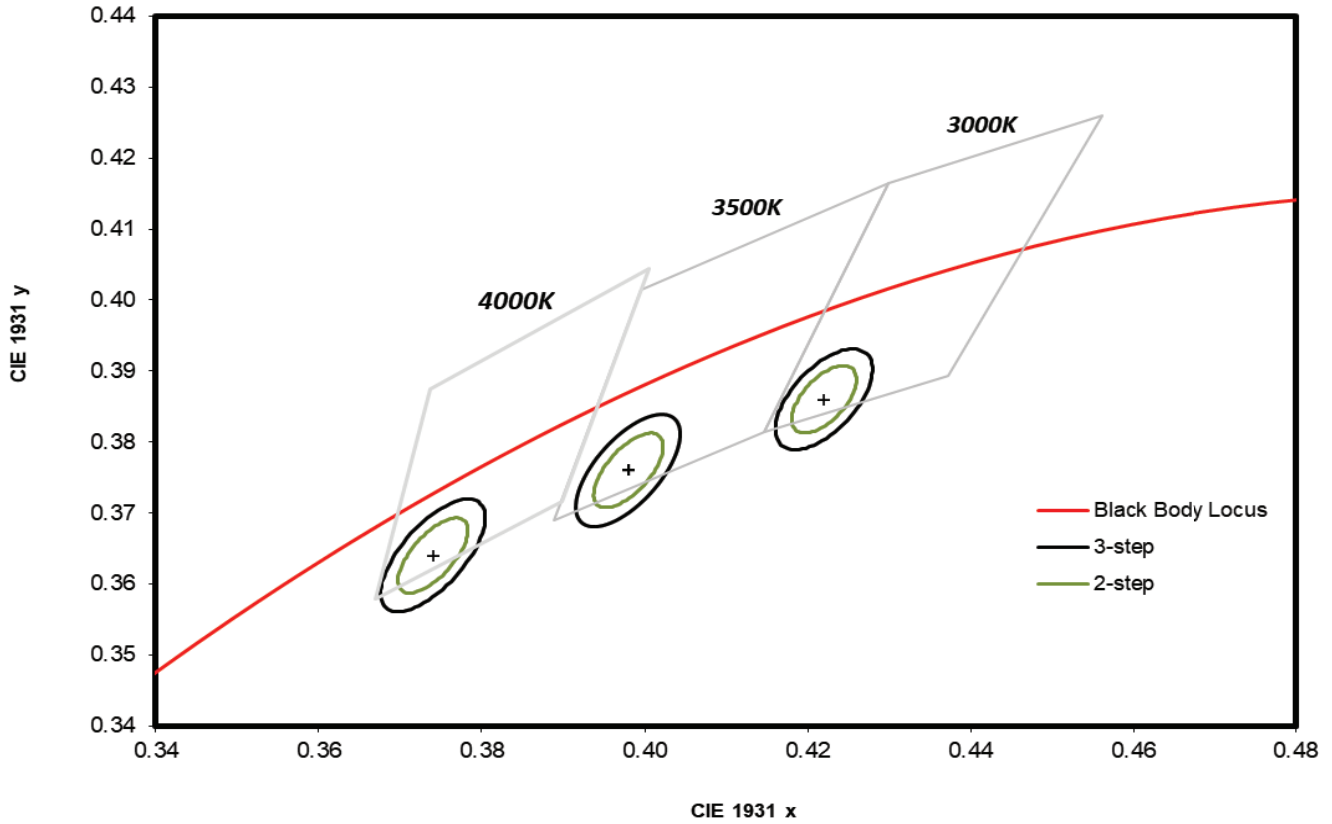

Figure 7. 2-step and 3-step MacAdam ellipse illustration for Table 5.

Table 5. 2-step and 3-step MacAdam ellipse color bin definitions for LUXEON CoB Core Range PW.

NOMINAL CCT	COLOR SPACE	CENTER POINT <sup>[1]</sup> (cx, cy)	MAJOR AXIS, a		MINOR AXIS, b		ELLIPSE ROTATION ANGLE, $\theta$
			2-step	3-step	2-step	3-step	
3000K	2-step, 3-step MacAdam ellipse	(0.422, 0.386)	0.00556	0.00834	0.00272	0.00408	53.20°
3500K	2-step, 3-step MacAdam ellipse	(0.398, 0.376)	0.00618	0.00927	0.00276	0.00414	54.00°
4000K	2-step, 3-step MacAdam ellipse	(0.374, 0.364)	0.00626	0.00939	0.00268	0.00402	53.70°

Notes for Table 5:

1. Lumileds maintains a tolerance of  $\pm 0.005$  on x and y coordinates in the CIE 1931 color space.

# Mechanical Dimensions

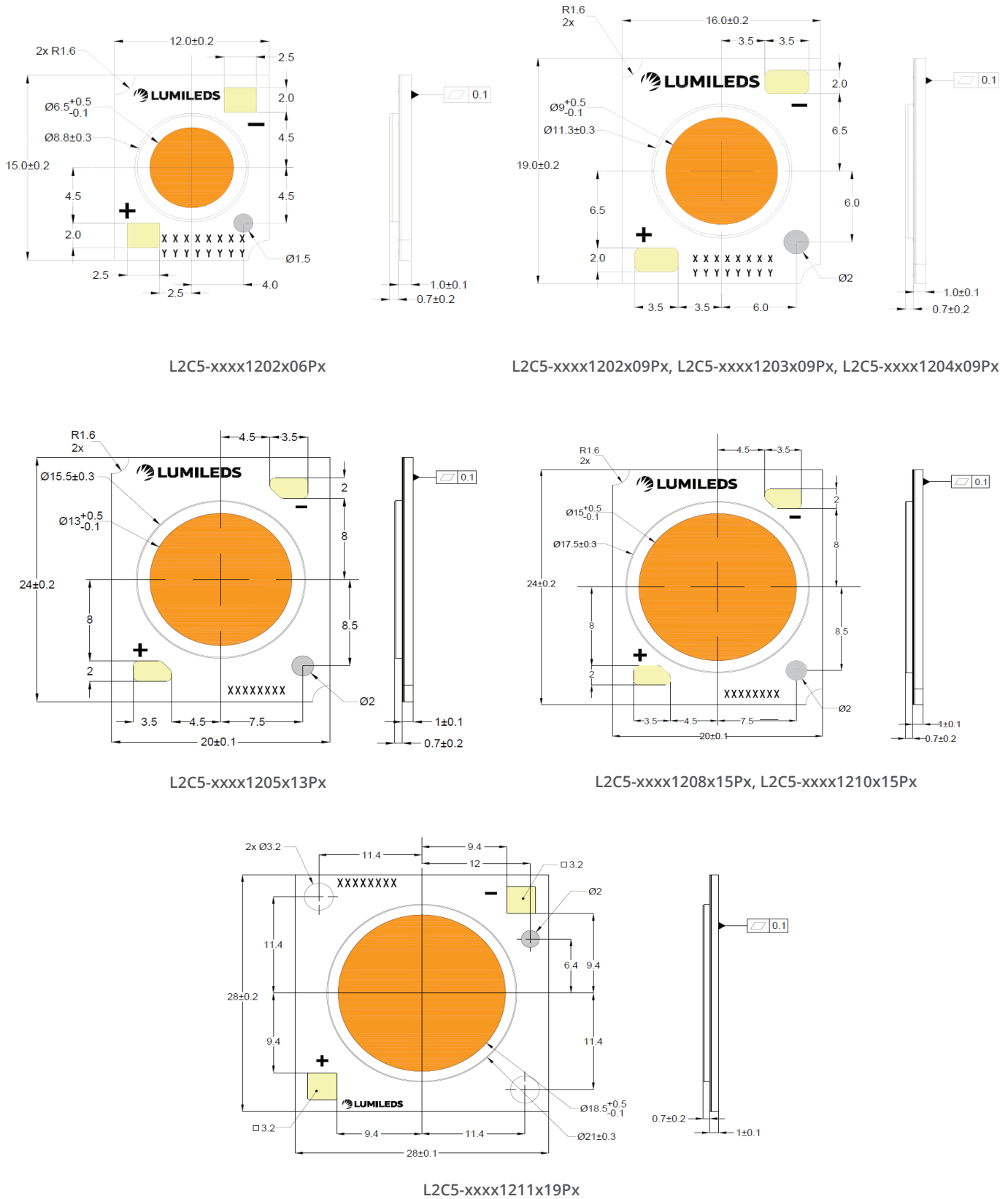

Figure 8. Mechanical dimensions for LUXEON CoB Core Range PW.

**Notes for Figure 8:**

1. Drawings not to scale.
2. All dimensions are in millimeters.
3. Dam heights: 0.7mm is applicable to L2C5-xx90xxxxxxx, 0.5mm to L2C5-xx80xxxxxxx.

# Packaging and Labeling Information

LUXEON CoB Core Range PW LEDs are packaged in tubes then in a carton box. Each tube contains a specified number of LEDs. The LEDs in each tube come from a single category code, ensuring they are all well-matched for light output, color, and forward voltage. Each tube contains a rubber stopper at one end. The tube label has both alphanumeric and bar code information. The carton boxes have printed information providing part numbers with CAT codes that indicate luminous flux, color and forward voltage bins.

Table 6. Number of LEDs per tube for LUXEON CoB Core Range PW.

PART NUMBER	TOTAL UNITS PER TUBE	TOTAL TUBES PER INNER BOX	TOTAL UNITS PER INNER BOX
L2C5-xxxx1202x06Px	20	5	100
L2C5-xxxx1202x09Px	20	5	100
L2C5-xxxx1203x09Px	20	5	100
L2C5-xxxx1204x09Px	20	5	100
L2C5-xxxx1205F13Px	20	5	100
L2C5-xxxx1208F15Px	20	5	100
L2C5-xxxx1210F15Px	20	5	100
L2C5-xxxx1211F19Px	10	5	50

## Tube

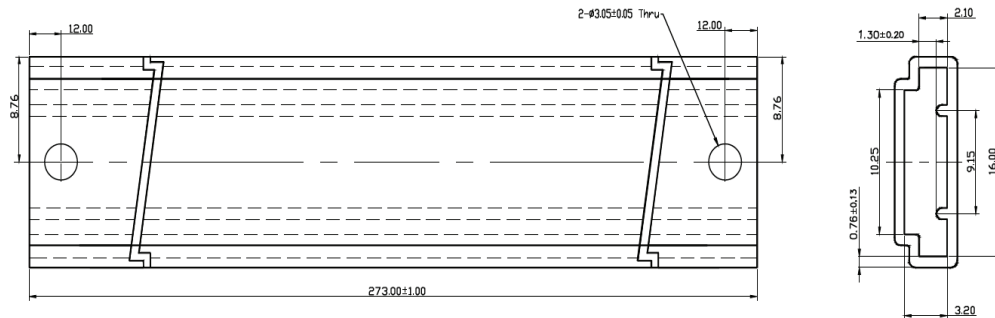

Figure 9a. Tube dimensions for L2C5-xxxx1202x06Px.

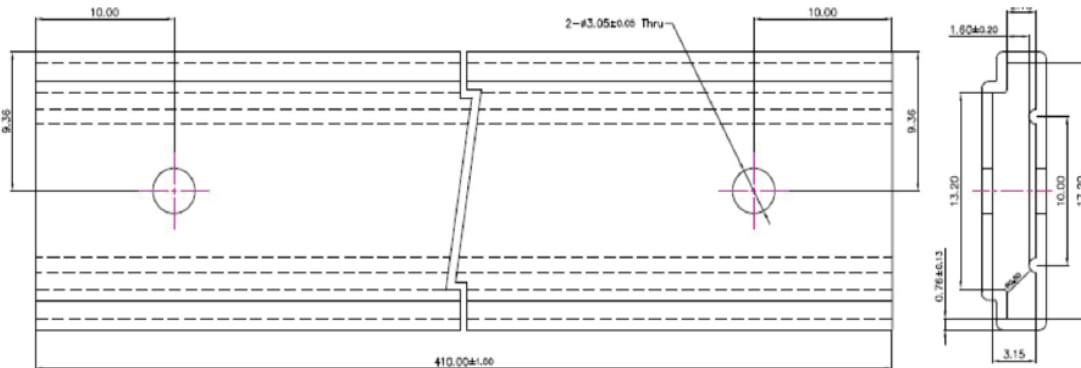

Figure 9b. Tube dimensions for L2C5-xxxx1202x09Px, L2C5-xxxx1203x09Px and L2C5-xxxx1204x09Px.

Notes for Figures 9a and 9b:

1. Drawings not to scale.
2. All dimensions are in millimeters.

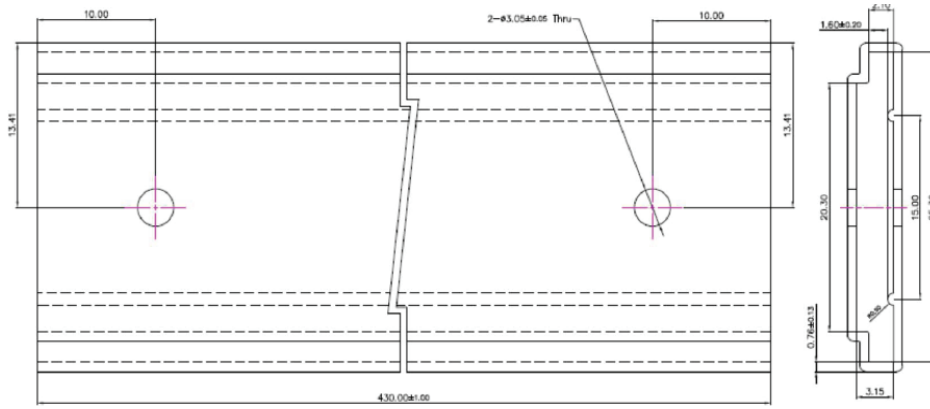

Figure 9c. Tube dimensions for L2C5-xxxx1205x13Px, L2C5-xxxx1208x15Px and L2C5-xxxx1210x15Px.

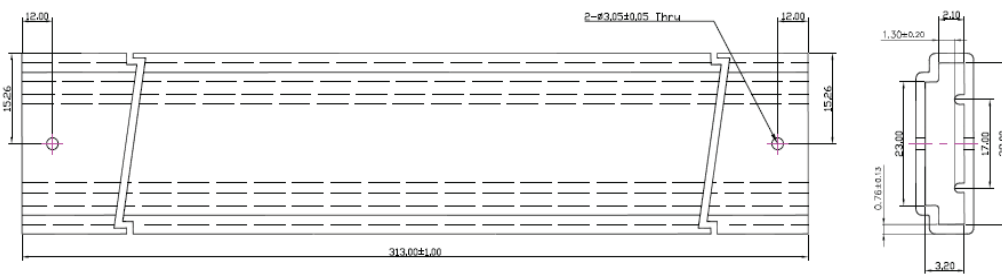

Figure 9d. Tube dimensions for L2C5-xxxx1211x19Px.

Notes for Figures 9c and 9d:

1. Drawings not to scale.
2. All dimensions are in millimeters.

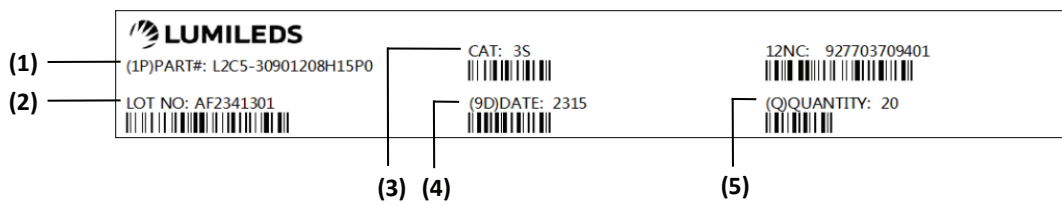

Figure 10. Example of a tube label for LUXEON CoB Core Range PW.

Notes for Figure 10 - Tube Label descriptions for customer use:

Field labels not described are for Lumileds internal use only.

1. Lumileds part number.
2. Unique production lot identification number. This number is required for traceability purpose.
3. Product category code.
4. LED test date in YYWW format.
5. Number of LED emitters in a tube.

# Inner Box

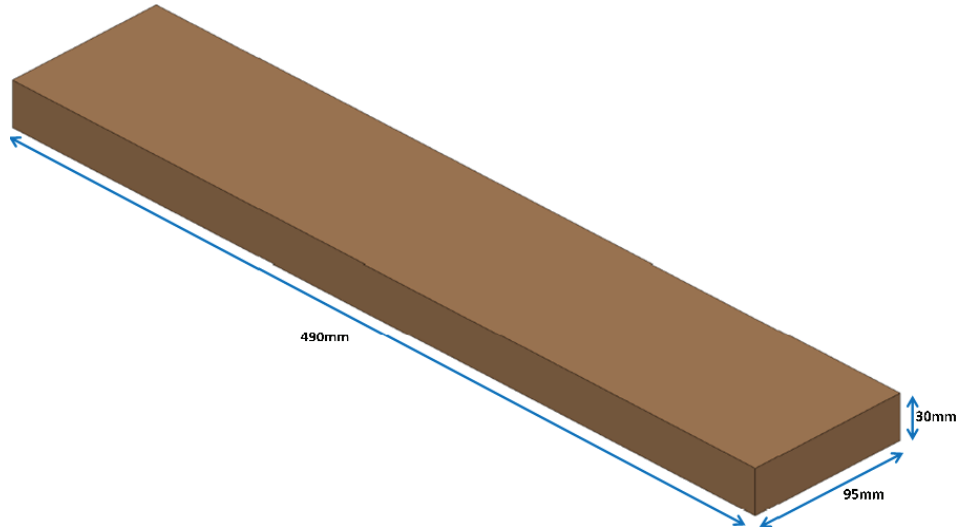

Figure 11. Dimensions for inner box packaging for LUXEON CoB Core Range PW.

Table 7. Inner box information for LUXEON CoB Core Range PW.

BOX TYPE	DIMENSIONS (mm)			AVERAGE WEIGHT (100pcs/box)	AVERAGE WEIGHT (50pcs/box)
	H	L	W		
Inner Box	30	490	95	0.340Kg	0.305Kg



Figure 12. Example of inner box label for LUXEON CoB Core Range PW.

Notes for Figure 12 – Inner Box Label descriptions for customer use:

Field labels not described are for Lumileds internal use only.

1. Number of LED emitters in a box.
2. Lumileds part number.
3. Customer part number for custom requests only.
4. LED test date in YYYY format.
5. Unique production lot identification number. This number is required for traceability purpose.
6. Product category code.
7. EU regulatory address.

# Outer Box

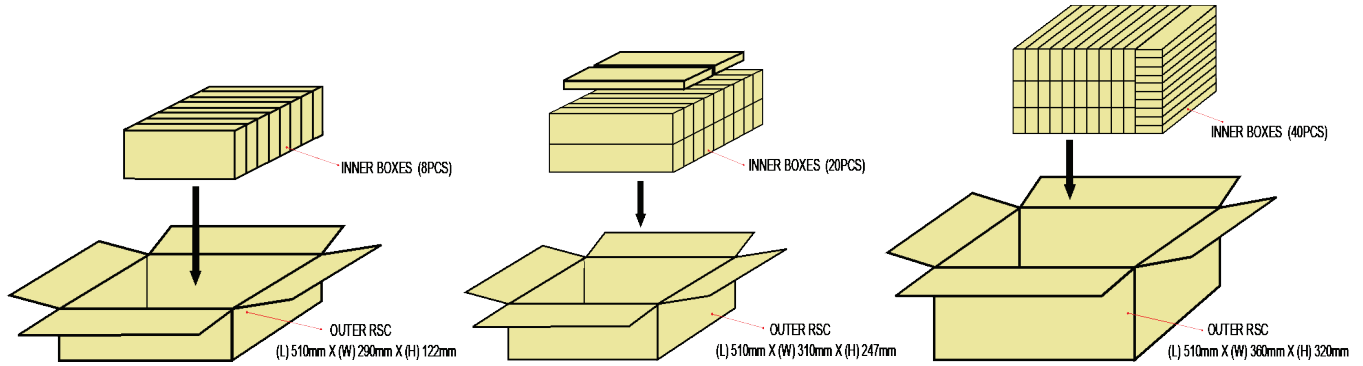

Figure 13. Dimensions for outer box packaging for LUXEON CoB Core Range PW.

Table 8. Outer box information for LUXEON CoB Core Range PW.

BOX TYPE	DIMENSIONS (mm)			MAXIMUM INNER BOXES PER OUTER BOX	MAXIMUM QUANTITY PER OUTER BOX	AVERAGE WEIGHT (100pcs/box)	AVERAGE WEIGHT (50pcs/box)
	H	L	W				
Outer Box 8	122	510	290	8	800	3.05kg	2.77kg
Outer Box 20	247	510	310	20	2000	7.55kg	6.85kg
Outer Box 40	320	510	360	40	4000	15.10kg	13.70kg



Figure 14. Example of outer box label for LUXEON CoB Core Range PW.

Notes for Figure 14 – Outer Box Label descriptions for customer use:  
Field labels not described are for Lumileds internal use only.

1. Lumileds part number.
2. Customer part number for custom requests only.
3. Unique production lot identification number. This number is required for traceability purpose.
4. Total number of LED emitters in a shipment box.

## About Lumileds

Companies developing automotive, mobile, IoT and illumination lighting applications need a partner who can collaborate with them to push the boundaries of light. With over 100 years of inventions and industry firsts, Lumileds is a global lighting solutions company that helps customers around the world deliver differentiated solutions to gain and maintain a competitive edge. As the inventor of Xenon technology, a pioneer in halogen lighting and the leader in high performance LEDs, Lumileds builds innovation, quality and reliability into its technology, products and every customer engagement. Together with its customers, Lumileds is making the world better, safer, more beautiful—with light.

To learn more about our lighting solutions, visit [lumileds.com](https://lumileds.com).



©2024 Lumileds Holding B.V. All rights reserved.  
LUXEON is a registered trademark of the Lumileds Holding B.V. in the United States and other countries.  
[lumileds.com](https://lumileds.com)

Neither Lumileds Holding B.V. nor its affiliates shall be liable for any kind of loss of data or any other damages, direct, indirect or consequential, resulting from the use of the provided information and data. Although Lumileds Holding B.V. and/or its affiliates have attempted to provide the most accurate information and data, the materials and services information and data are provided “as is,” and neither Lumileds Holding B.V. nor its affiliates warrants or guarantees the contents and correctness of the provided information and data. Lumileds Holding B.V. and its affiliates reserve the right to make changes without notice. You as user agree to this disclaimer and user agreement with the download or use of the provided materials, information and data. A listing of Lumileds product/patent coverage may be accessed at [lumileds.com/patents](https://lumileds.com/patents).