

# LUXEON Rebel Platform

## Assembly and Handling Information



### Introduction

This application brief covers recommended board designs and assembly procedures for the LUXEON LEDs referenced below in the scope.

LUXEON LEDs are revolutionary, ultra-compact, surface mount, high-power LEDs. These LEDs offer a compact package with high lumen output and superior thermal performance. The compact design allows close packing for maximum light output per unit area of board space while retaining high efficacy and maximum lumen maintenance. Proper handling, board design, and thermal management are required in order to ensure high optical output and long LED lumen maintenance times.

### Scope

The assembly and handling guidelines in this application brief apply to the following LUXEON products:

- 
- |  |                     |
|--|---------------------|
| • LUXEON R   | • LUXEON Rebel ES   |
| • LUXEON Rebel (Automotive & General Illumination) | • LUXEON Rebel Plus |
| • LUXEON Rebel Color                               |                     |
- 

The LUXEON LEDs that belong to these product categories have very similar form factors. Consequently, most handling requirements and board design recommendations in this Application Brief apply to all LEDs. Any handling requirements that are specific to a subset of LUXEON LEDs will be clearly marked.

In the remainder of this document the term LUXEON LED refers to any LED that belongs to one of the LUXEON products listed above.

# Table of Contents

Introduction .....	1
Scope .....	1
<b>1. Component .....</b>	<b>3</b>
1.1. Description .....	3
1.2. Optical Center .....	3
1.3. Lens Handling .....	7
1.4. Lens Cleaning .....	7
1.5. Electrical Isolation .....	7
<b>2. Board Design Rules .....</b>	<b>8</b>
2.1. PCB Requirements .....	8
2.2. LUXEON LED Footprint and Land Pattern .....	8
2.3. Surface Finishing .....	10
2.4. LUXEON LED Close Proximity Placement .....	10
<b>3. FR4-Based Boards .....</b>	<b>10</b>
3.1. Material Properties .....	10
3.2. Optimal Thermal Design .....	10
3.3. Thermal Via Design .....	12
3.4. Component Spacing .....	14
3.5. Thermal Resistance .....	15
3.6. FR4 Board Handling .....	19
<b>4. MCPCB Board design .....</b>	<b>21</b>
<b>5. Assembly Process Recommendations and Parameters .....</b>	<b>23</b>
5.1. Stencil Design .....	23
5.2. Solder Paste .....	24
5.3. Pick and Place Nozzle .....	24
5.4. Pick and Place Machine Optimization .....	27
5.5. Placement Accuracy .....	30
5.6. Reflow Profile .....	31
5.7. Reflow Accuracy .....	32
5.8. Void Inspection and Solderability Indicators .....	33
<b>6. JEDEC Moisture Sensitivity Level .....</b>	<b>35</b>
<b>7. Product Packaging Considerations — Chemical Compatibility .....</b>	<b>36</b>
About Lumileds .....	38

# 1. Component

## 1.1. Description

A LUXEON LED is a revolutionary, ultra-compact, surface mount, high-power LED which comes in two different mechanical configurations:

- Configuration A: A LUXEON LED with this configuration has a flat surface area outside the silicone lens. This configuration is used for all LUXEON Rebel Color and LUXEON Rebel White LEDs (datasheets DS58, DS64, and DS68).
- Configuration B: A LUXEON LED with this configuration has a transient voltage suppressor chip in a separate pocket on the ceramic substrate. This configuration is used for all LUXEON Rebel ES, and LUXEON R LEDs (datasheets DS61 and DS101).

Cross sections for both configurations are shown in Figure 1, highlighting the main components of a LUXEON LED.

Each LUXEON LED contains a high brightness LED chip on a ceramic substrate. The ceramic substrate provides mechanical support and thermally connects the LED chip to a heat pad on the bottom of the substrate. An electrical interconnect layer connects the LED chip to a cathode and anode (not visible in the cross sections) on the bottom of the substrate. A silicone lens above the LED chip extracts the light that is generated inside the LED chip. All InGaN LUXEON LEDs contain a transient voltage suppressor (TVS) chip which protects the LED chip against electrostatic discharge (ESD) events.

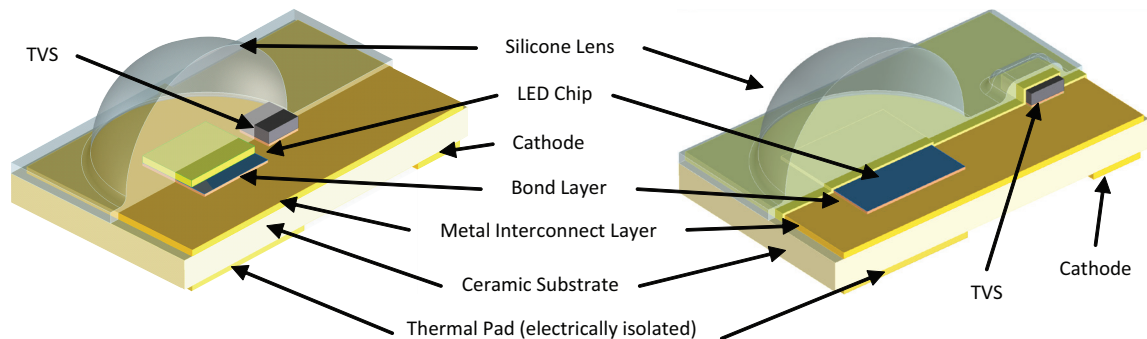

Figure 1. A LUXEON LED comes in two different configurations. Configuration A (left) has a planar surface outside the silicone lens while configuration B (right) has a TVS which resides inside a special pocket on the ceramic substrate outside the silicone lens (right).

## 1.2. Optical Center

A LUXEON LED contains three feature sets that locate the theoretical optical center. These features are the topside fiducials, backside metallization, and LED outline.

### Fiducial marks on a LUXEON LED (configuration A)

The fiducial marks on a LUXEON LED (configuration A) provide the most accurate methodology to locate the theoretical optical center as shown in Figure 2. To find the optical center of a LUXEON LED, use the fiducials on the LED package as follows:

1. Draw an imaginary line between the centers of fiducials F1 and F2.
2. Using fiducial F2 as the pivot point, rotate the line 19.66° counter clockwise.
3. The theoretical optical center lies on this line and is 2.248mm above the center of F2.

Once the theoretical optical center has been located, the actual optical center of a LUXEON LED (configuration A) is within a circular diameter of 0.29mm with respect to the theoretical optical center.

Note that the nominal position of the fiducials on a LUXEON LED (configuration A) is identical for all colors. However, there is a difference in the metallization pattern between InGaN and AlInGaP LUXEON LEDs, as indicated in Figure 3.

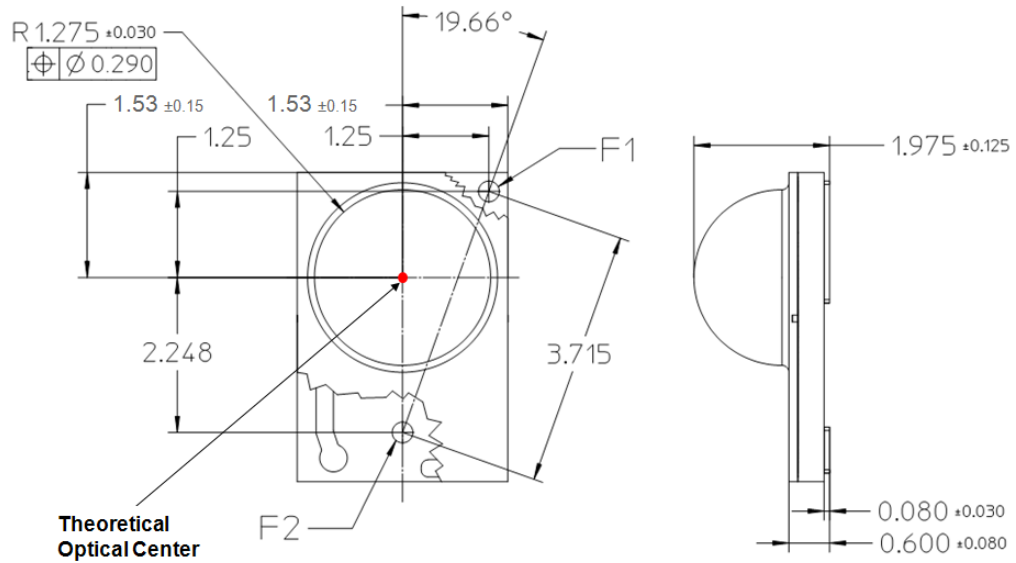

Figure 2. The most accurate method to find the theoretical optical center and the center of the silicone lens is by using the fiducials located on the front side of a LUXEON LED (configuration A). All dimensions are in mm.

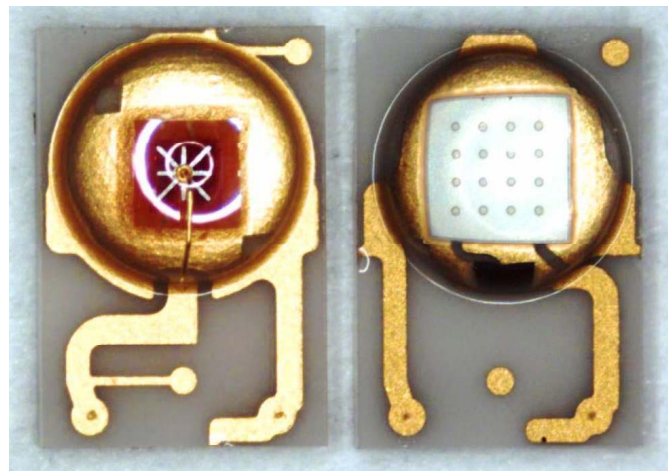

Figure 3. Top views of AlInGaP and InGaN LUXEON LEDs (configuration A). The fiducials on an AlInGaP LUXEON LED (left) are connected to the metallization patterns while the fiducials on an InGaN LUXEON LED (right) are isolated.

### Fiducial Marks for a LUXEON LED (configuration B):

A LUXEON LED (configuration B) has two fiducial marks labeled F1 and F2 as shown in Figure 4. An optional third fiducial, F3, may be present as well. These fiducial marks provide the most accurate methodology to locate the theoretical optical center, marked by the red dot in Figure 4. The theoretical optical center is located 1.450mm from the vertical and horizontal edges of fiducial marks F1 and F2. The theoretical optical center also lies 1.577mm above the center of fiducial F3, if present, along an imaginary line drawn between the center of fiducial F3 and the midpoint between fiducials F1 and F2. The actual optical center of a LUXEON LED (configuration B) is within a circular diameter of 0.290mm with respect to the theoretical optical center.

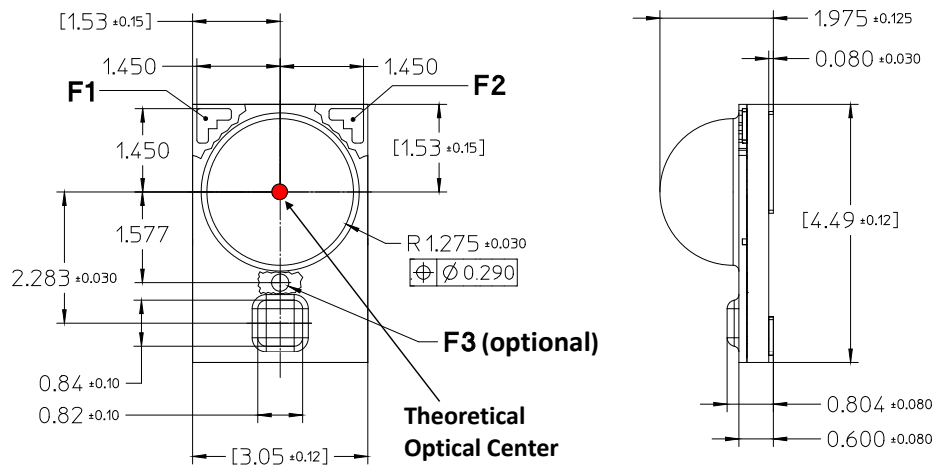

Figure 4. The fiducial marks on the front side of a LUXEON LED (configuration B) provide the most accurate method to find the theoretical optical center. All dimensions are in mm.

Figure 5 shows the typical metallization pattern of a LUXEON LED (configuration B).

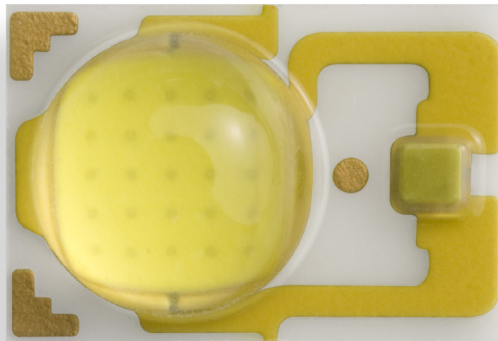

Figure 5. Typical metallization pattern of a LUXEON LED (configuration B). The TVS in this configuration resides in a separate pocket on the ceramic substrate.

## LED Outline and Backside Metallization

While the fiducial marks provide the most accurate technique to find the optical center of the silicone lens, one can also use the edges or the backside metallization to locate the theoretical optical center of a LUXEON LED. Figure 2 and Figure 4 illustrate the position of the optical center with respect to the edges of the ceramic substrate for the two different LUXEON LED configurations. In both configurations the optical center is located 1.525mm from the top and side of the LUXEON LED edges.

The optical center can also be located using the edges of the thermal pad on the bottom of the ceramic substrate as shown in Figure 6. The actual position of the center of the lens will be within a circle with a diameter of 0.350mm with respect to the theoretical optical center found using the edges of the thermal pad as a reference.

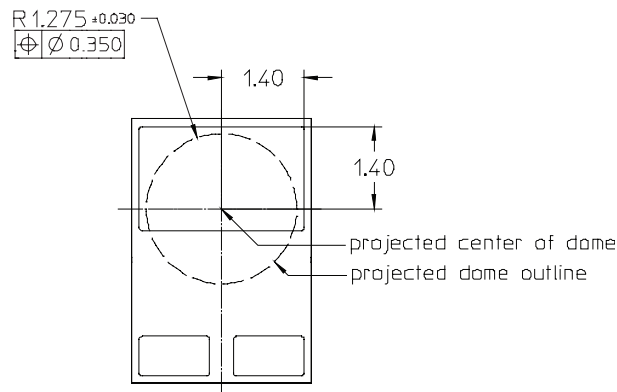

Figure 6. The theoretical optical center may be located using the edges of the thermal pad on the bottom of a LUXEON LED. The center of the silicone lens will be within a 0.35mm radius with respect to the theoretical optical center. All dimensions are in mm.

### 1.3 Lens Handling

A LUXEON LED is designed to maximize light output and reliability. However, improper handling of a LUXEON LED may damage the silicone lens and affect the overall light performance and reliability.

To minimize the risk of damage to the silicone lens during manual handling, only pick up LUXEON LEDs from the sides of the ceramic substrate and never from the silicone lens itself (see Figure 7).

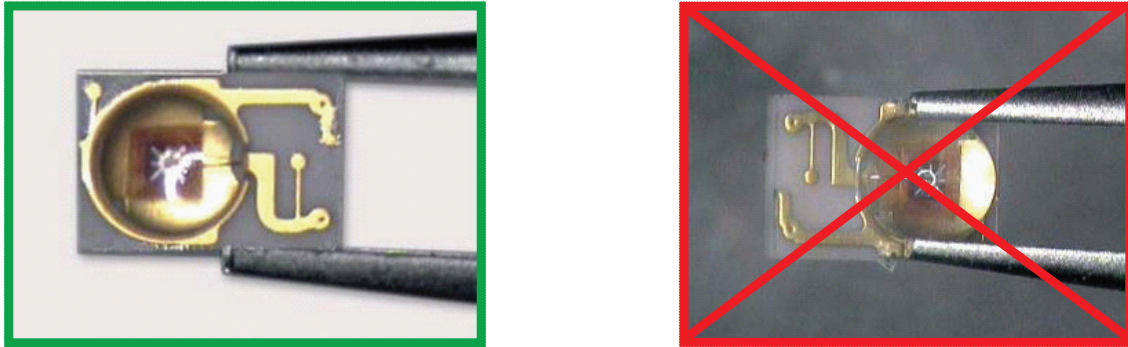

Figure 7. Correct handling (left) and incorrect handling (right) of a LUXEON LED.

Due to its small size, the silicone lens of a LUXEON LED can only withstand a limited amount of force. In order to avoid any mechanical damage to the silicone lens of a LUXEON LED or to the LED chip inside the LUXEON LED, do not apply more than 3N of shear force (300g) directly onto the lens. When utilizing a pick and place machine, always ensure that the pick and place nozzle does not place excessive pressure onto the silicone lens of a LUXEON LED. For more information see section 5.3 Pick and Place Nozzle of this document. Similar restrictions exist for manual handling.

### 1.4 Lens Cleaning

The silicone lens of a LUXEON LED should not be exposed to dust and debris. Excessive dust and debris may cause a drastic decrease in optical output. In the event that an emitter requires cleaning, first try a gentle swabbing using a lint-free swab. If needed, a lint-free swab and isopropyl alcohol (IPA) can be used to gently remove dirt from the lens. Do not use other solvents as they may adversely react with a LUXEON LED. For more information regarding chemical compatibility, see section 7. Product Packaging Considerations — Chemical Compatibility.

### 1.5 Electrical Isolation

The ceramic substrate of a LUXEON LED electrically isolates the thermal pad from the LED cathode and anode (see the cross sections in Figure 1). Consequently, a high voltage difference between the electrical and thermal metallization may occur in applications where multiple LUXEON LEDs are connected in series. As a reference, the minimum distance between the top electrical metallization and the bottom thermal metallization of a LUXEON LED, considering x, y and z dimensions, is  $> 0.35\text{mm}$ .

In order to avoid any electrical shocks and/or damage to LUXEON LEDs, each design needs to comply with the appropriate standards of safety and isolation distances, known as clearance and creepage distances, respectively. Compliance with appropriate standards is application and design specific. Examples of standards are IEC 60065 for audio/video equipment and IEC 60598 for general lighting applications.

With proper use of electrical isolation and circuitry (e.g. short-circuits protection) the length of a series of LUXEON LEDs can be many tens of units long.

## 2. Board Design Rules

### 2.1 PCB Requirements

A LUXEON LED is designed to be mounted on a two-layer FR4 PCB (Printed Circuit Board), a multi-layer FR4 PCB or an MCPCB (Metal Core Printed Circuit Board). To ensure optimal operation of a LUXEON LED, the thermal path between the LED package and the heat sink should have a thermal resistance as low as feasible.

Historically, MCPCB has been used for its low thermal resistance and rigidity. However, MCPCB is not always the most economical solution for certain applications. A two layer FR4 board (with open vias or filled and capped vias), in contrast, often offers a much lower cost solution for a thermally efficient package. By following the guidelines outlined below, one can achieve a thermal resistance for FR4 PCB that is equivalent to or lower than a MCPCB equivalent design with lower cost than that of MCPCB.

For reference, here are the applicable IPC standards when designing PCB boards.

- General PCB design:
  - IPC A-610D: Acceptability of Electronic Assemblies
- Filled and capped via boards:
  - IPC 4761: Design Guide for Protection of Printed Board Via Structures
  - IPC 2315: Design Guide for High Density Interconnects and Micro Vias
  - IPC 2226: Design Standard for High Density Interconnect Printed Boards

### 2.2 LUXEON LED Footprint and Land Pattern

Lumileds has conducted an investigation to determine the optimal land pattern design for a LUXEON LED on a PCB. The goal of this study was to create a board with low thermal resistance, high placement accuracy, a minimum number of solder voids, and solderability indicators.

Figure 8 shows the individual layers of the suggested layout with solderability indicators for an open via Plated Through Hole (PTH) board design. The green solder mask is a photolithographic mask, which offers a highly accurate alignment to the copper layer. The white mask labeled “White Text” is a printed layer consisting of a double printed layers of for instance, Tamura USI-210WP ink (UL E38152). This white layer enhances light reflectivity, but is optional.

The solderability indicators, shown as the diagonally extended copper areas on the thermal and electrical land patterns, provide visual proof of effective solder reflow on all pads. In addition to acting as solderability indicators, the extended area can also be electrically probed during quality control tests. Reflow placement accuracy and thermal resistance will not be affected by the removal of the solderability indicators in the layout.

In this discussion, the term Land Pattern refers to the pattern on the PCB for the pads of a LUXEON LED.

The land pattern designs are available as .dxf file on the Lumileds website at [lumileds.com](http://lumileds.com).



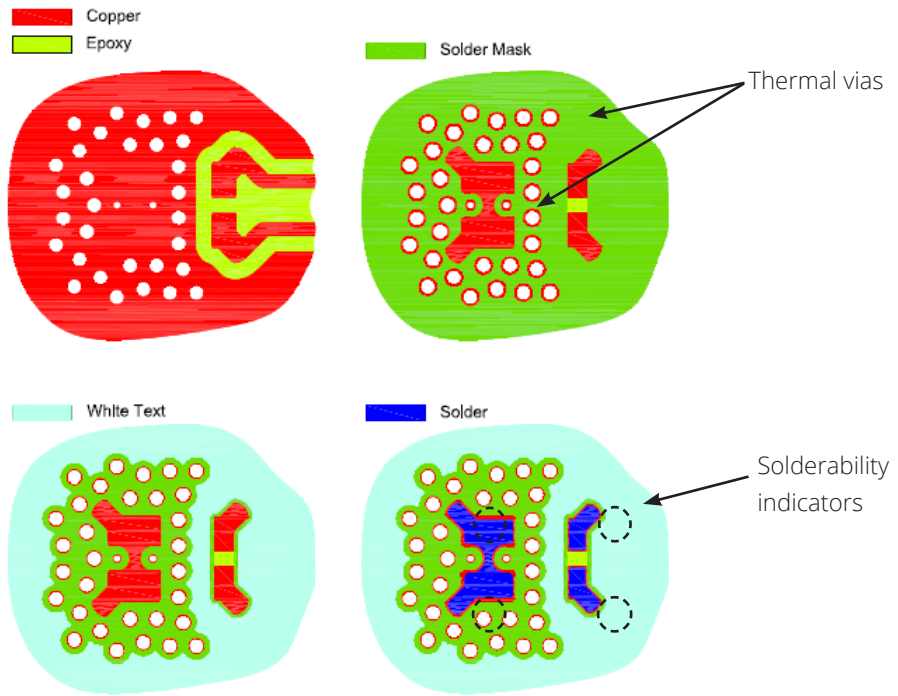

Figure 8. Recommended layout for a LUXEON LED with open via PTH board.

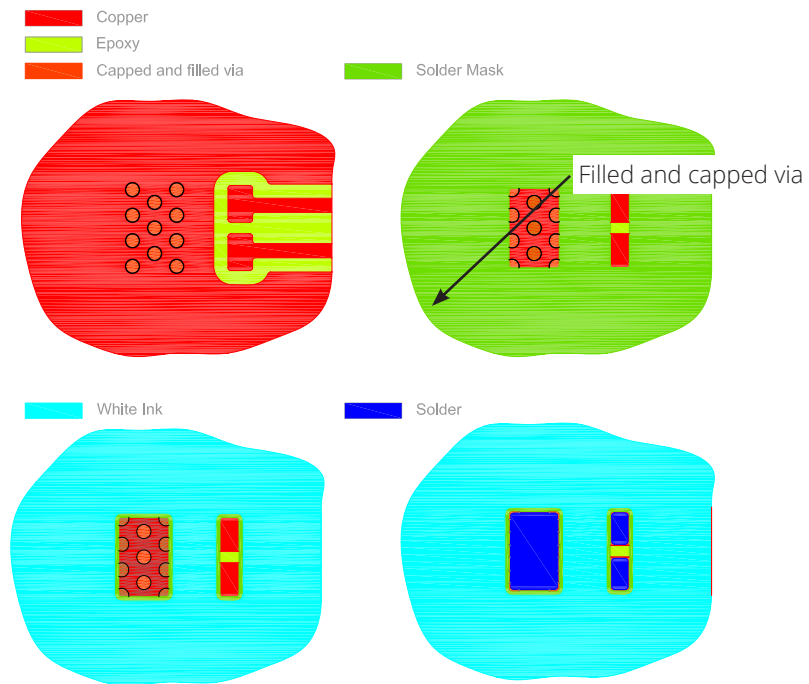

Figure 9. Recommended layout for a LUXEON LED with filled and capped vias.

## 2.3 Surface Finishing

Lumileds recommends using a high temperature organic solderability preservative (OSP) on the copper layer.

## 2.4 LUXEON LED Close Proximity Placement

Lumileds recommends a minimal edge to edge spacing of 0.3mm between LUXEON LEDs. If the edge to edge spacing is less, the components may drift together during the solder step. Also, the light output for each LUXEON LED may drop due to optical absorption by adjacent LED packages. For open via PTH design, close spacing of LUXEON LEDs may require the removal of the solderability indicators shown in Figure 8. Removal of the solderability indicators does not affect the placement accuracy.

# 3. FR4-Based Boards

## 3.1 Material Properties

FR4 is an industry standard PCB technology. Depending on the LED application, drive condition and the number of LEDs on the board, the choice for Tg (Glass Transition Temperature) and CTI (Comparative Tracking Index) value of the base material needs to be set. Most common FR4 material has Tg=130°C and CTI=175V. For high voltage applications, the trace clearances and CTI values may be increased accordingly.

## 3.2 Optimal Thermal Design

Thermal vias are the primary method of heat transportation to the heat sink at the PCB bottom. A thermal via is a plated through hole that can be open, plugged, filled or filled and capped.

Lumileds conducted a study on two thermal via designs aimed at reducing the thermal resistance. They are (a) open via PTH and (b) filled and capped via.

### Open via PTH design

A cross section of this design is shown in Figure 10. The final thermal resistance is determined by the number and density of vias, the copper plating thickness and PTH thickness. Figure 11 shows a design with a standard two layer board. Here the total copper plating is 70µm with the PTH plating thickness of 35µm. In total, 33 vias are placed outside the thermal landing pad. The placement of the two smaller thermal vias is to minimize voiding in the solder joint. For the recommended design, the measured thermal resistance for a 0.8mm thick FR4 PCB with these design features approaches 7K/W.

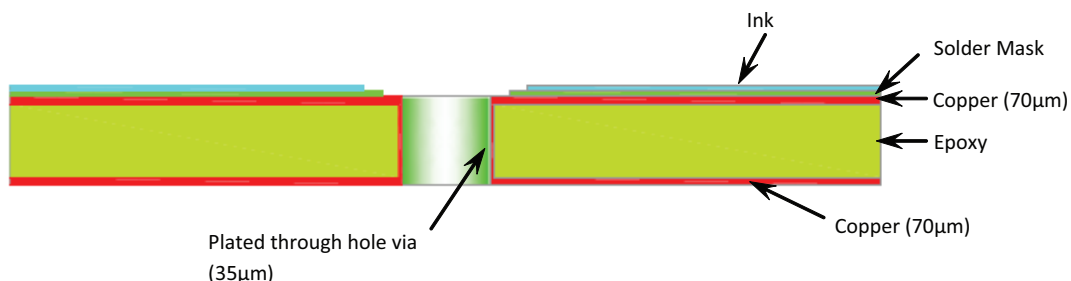

Figure 10. Cross section of FR4 based PCB with thermal vias to decrease the thermal resistance.

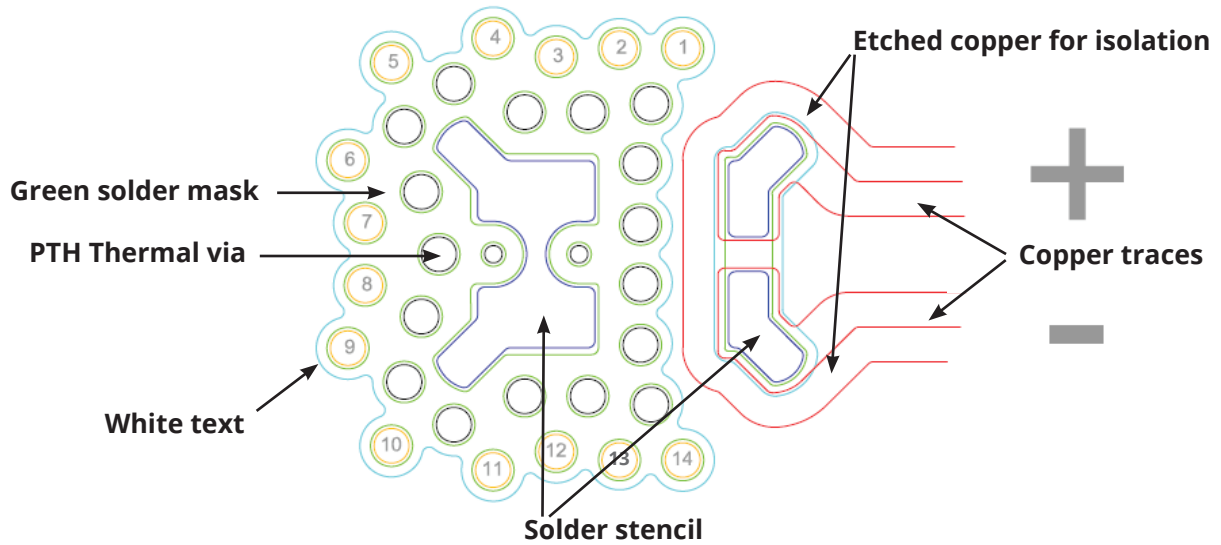

Figure 11. Outline of the recommended pad layout for a LUXEON LED (top view). See Figure 8 for more illustrations. There is 0.5mm spacing between the thermal and electrical pads.

### Filled and capped via design

A cross section of this design for a standard two layers board is shown in Figure 12. The final thermal resistance is determined by the number and density of vias, the copper plating thickness, PTH thickness and the plugging material used to fill the vias. Figure 13 shows the recommended layout for a two layer board. The thermal resistance for a 0.8mm thick FR4 PCB with these design features approaches 3K/W.

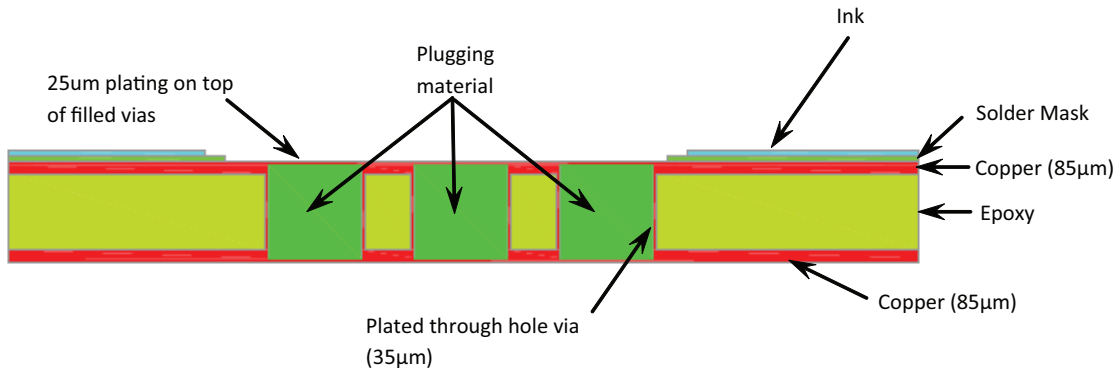

Figure 12. Cross section of FR4 based PCB with filled and capped thermal via for two layer board.

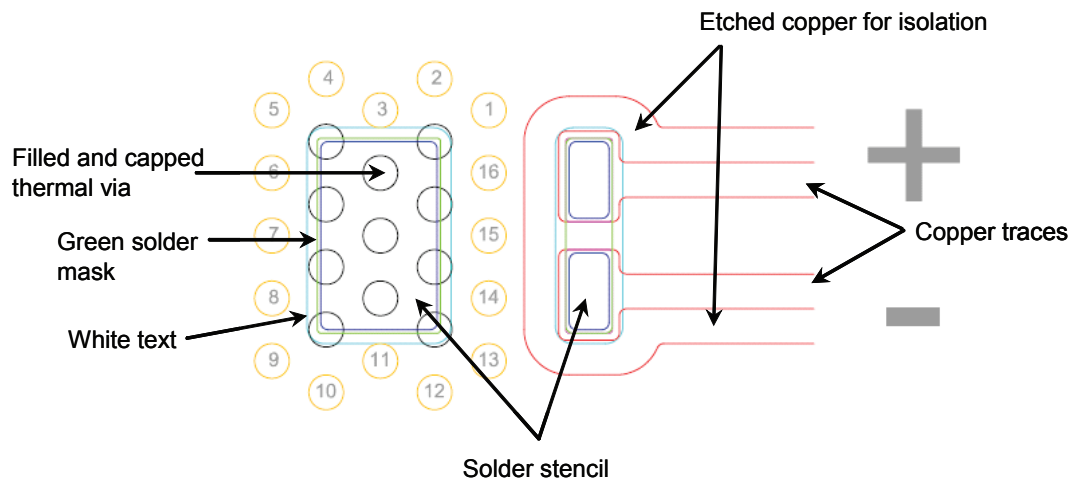

Figure 13. Outline of the recommended pad layout for a LUXEON LED on a PCB with filled and capped vias. See Figure 9 for alternate views.

A multilayer FR4 board with filled and capped via may be considered. See Figure 14 for a cross section of the multilayer board design.

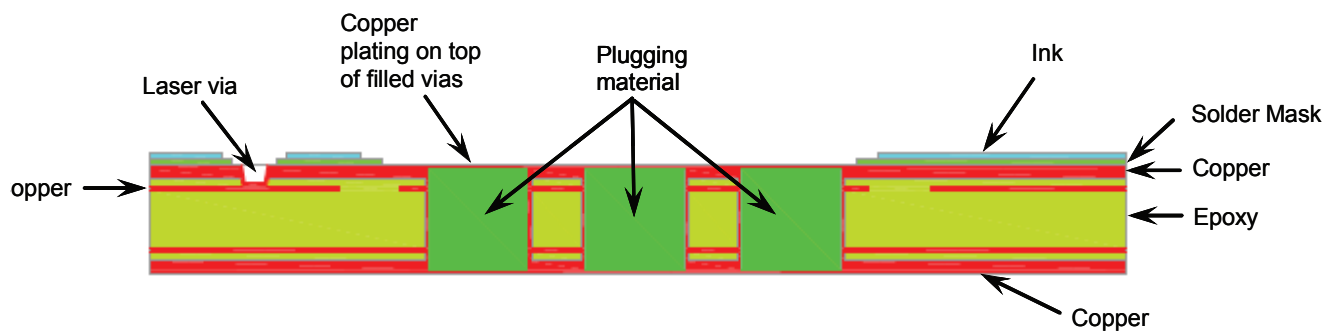

Figure 14. Cross section of filled and capped via multilayer board.

### 3.3 Thermal Via Design

For both the open via PTH and filled and capped via design, the finished hole diameter is 0.5mm. A smaller diameter will lead to an increased thermal resistance. The recommended distance between two holes is 0.4mm. This results in a minimal pitch of 0.9mm between the vias. Figure 15 indicates the typical dimensions. The position of the vias may differ from the preferred layout of Figure 11 and Figure 13, without significantly changing thermal properties.

For open via PTH design, the drill hole for the two smaller vias with a 35µm plating thickness is 0.32mm. The solder mask area around the vias is needed to avoid solder to flow through the vias to the backside. This would lead to a reduced heat sink contact of the PCB bottom surface. An opening in the solder mask of 0.05mm surrounds each via. The total minimal width of the solder mask around the via is 0.25mm. Figure 16 shows the resulting solder mask design of the thermal pad.

For filled and capped via design, each via is filled or plugged with an epoxy material. Standard industry practices recommend using a plugging material with a CTE (Coefficient of Thermal Expansion) and Tg to match the thermal characteristics of the PCB. Recommendations on qualification criteria for the plugging process are documented in IPC-4761 "Design Guide for Protection of Printed Board Via Structures." Use of thermally improved plugging material can further reduce the board thermal resistance, although the absolute improvement will be small.

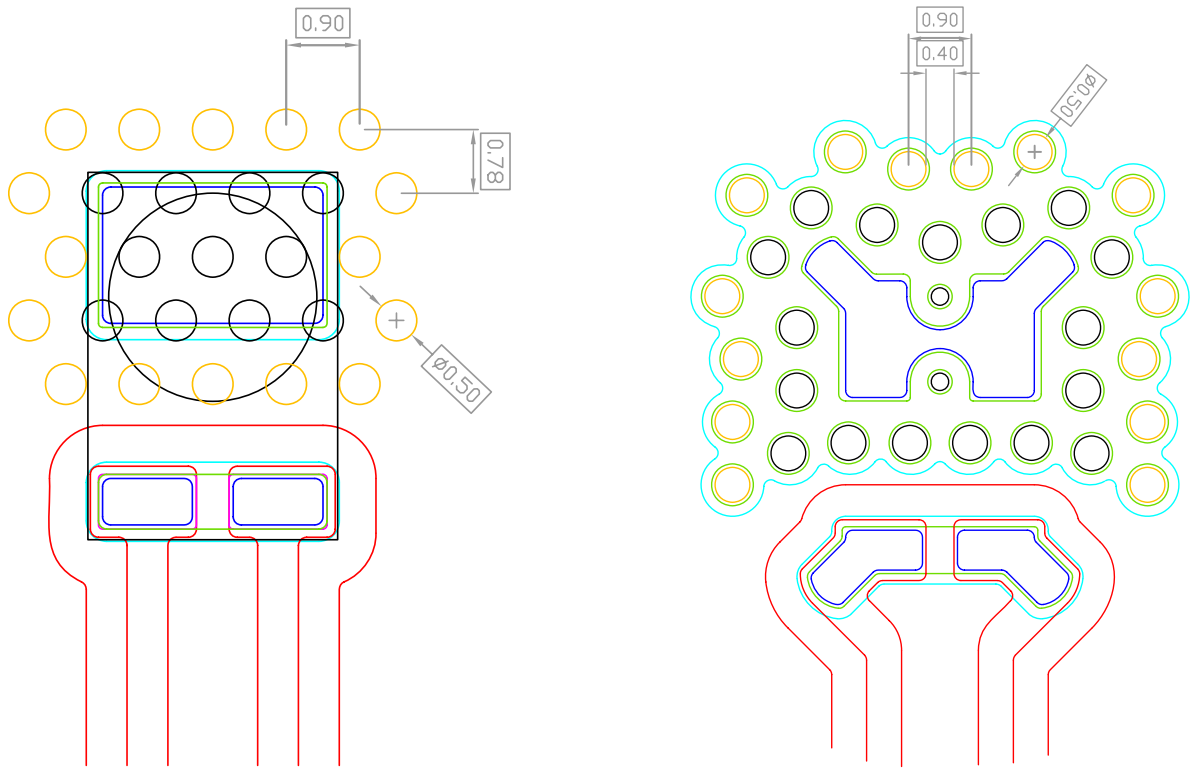

Figure 15. Recommended finished diameter and spacing dimensions for both open via PTH and filled and capped via design. All dimensions are in mm.

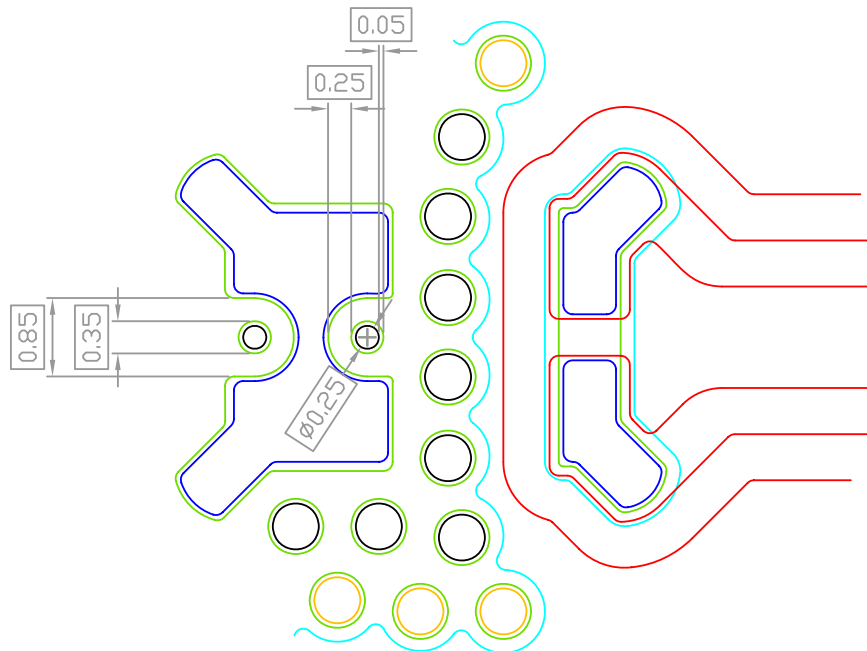
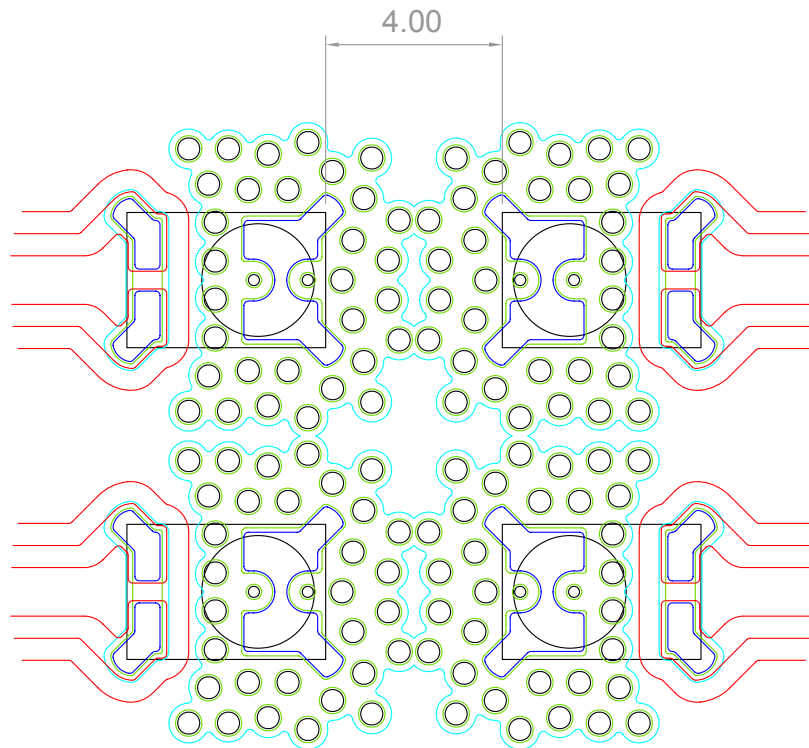

Figure 16. Solder mask design of thermal pad for open via PTH. All dimensions are in mm.

### 3.4 Component Spacing

For the open via PTH design, the minimal edge to edge spacing is 4mm to maintain the thermal properties, see Figure 17. Spacing below 4mm results in fewer vias between the components, thus increasing thermal resistance.



**Figure 17. Illustration of edge to edge spacing. The thermal resistance will increase dramatically if the spacing is less than 4mm edge to edge.**

For filled and capped vias with the above recommended design, the minimal edge to edge spacing is 0.3mm, see Figure 18. This board design yields higher component density while still achieving a low thermal resistance.

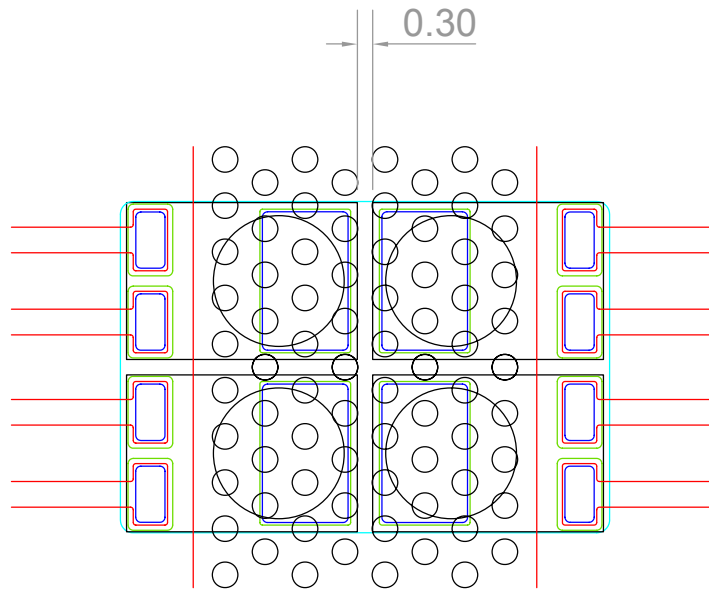

Figure 18. Illustration of edge to edge spacing for a filled and capped via design.

### 3.5 Thermal Resistance

The thermal resistance between the component case (body) and the back of the board/heatsink ( $R\theta_{c-hs}$ ) of the PCB depends on the size of Cu area around the thermal pad, the number of vias, the placement of vias, the Cu plating thicknesses, and the PCB thickness.

#### Effect of PCB thickness and plating thickness

Figure 19 shows simulated  $R\theta_{c-hs}$  values for open PTH and filled and capped via as a function of PCB thickness. A double layer FR4 board with various through hole plating thicknesses (20 $\mu$ m and 35 $\mu$ m) and total surface plating (50 $\mu$ m and 70 $\mu$ m for open PTH, 70 $\mu$ m and 85 $\mu$ m for filled and capped via) are studied. The open PTH via board design uses 33 vias and the filled and capped design uses 27 vias. Data is for a single LUXEON LED.

The thicker the PCB board, the higher is the thermal resistance. Thicker plating thickness for the thermal via will reduce the thermal resistance and vice versa.

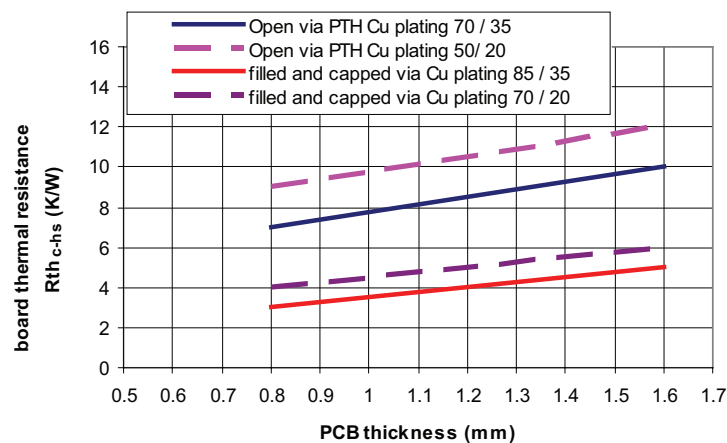

Figure 19.  $R\theta_{c-hs}$  values as function of PCB thickness for two layers FR4 board with different plating thicknesses.

## Impact of the thermal via count

For an open via PTH board, removal of the 14 outer vias increases the thermal resistance by approximately 1K/W. The 14 outer vias are labeled in Figure 11. Eliminating the two smaller vias in the thermal landing pad increases the  $R\theta_{c-hs}$  value by 1 K/W as well since the copper area around the thermal landing pad has a large contribution to the thermal spreading. The optimal copper area extends 3mm beyond the thermal pad. Any extension beyond 3mm will not significantly lower the thermal resistance. Elimination of both the outer vias and the copper area outside the thermal pad increases the thermal resistance to above 30K/W.

With filled and capped vias, the thermal resistance decreases from 4K/W to 3K/W when adding the additional vias around the 11 vias in the thermal landing pad as shown in Figure 18.

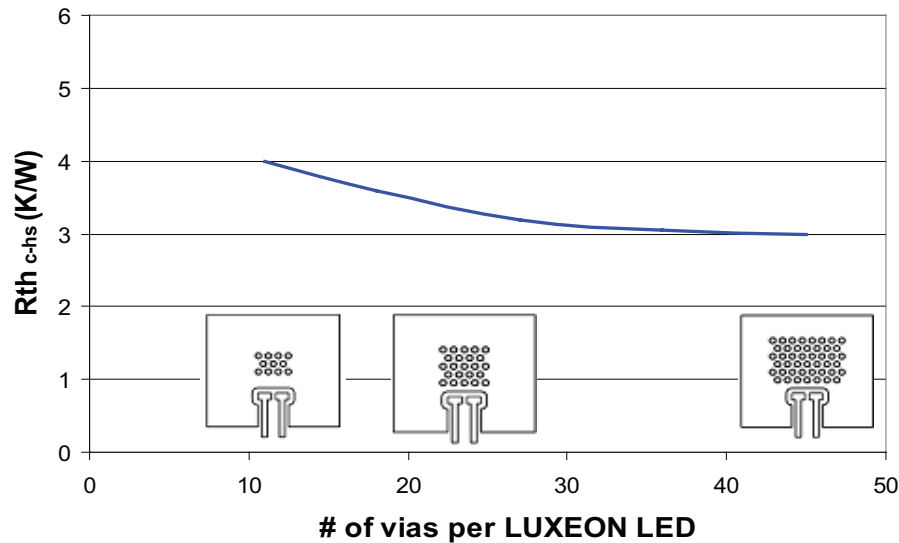

Figure 20. Simulation of the thermal resistance as a function of number of vias (filled and capped via).

## Effect of component density

For an open via PTH, bringing the components closer together than 4mm will lead to elimination of vias and decreases the copper area around the thermal pad. If the spacing is less than 2mm, the thermal resistance will increase dramatically. Figure 21 shows the simulated thermal resistance as a function of spacing. Figure 22 shows the reduction of vias when the spacing decreases from 4mm to 2mm. These simulation results correspond to a 0.8mm FR4 board thickness with 70 $\mu$ m of total copper plating and 35 $\mu$ m copper plating via.



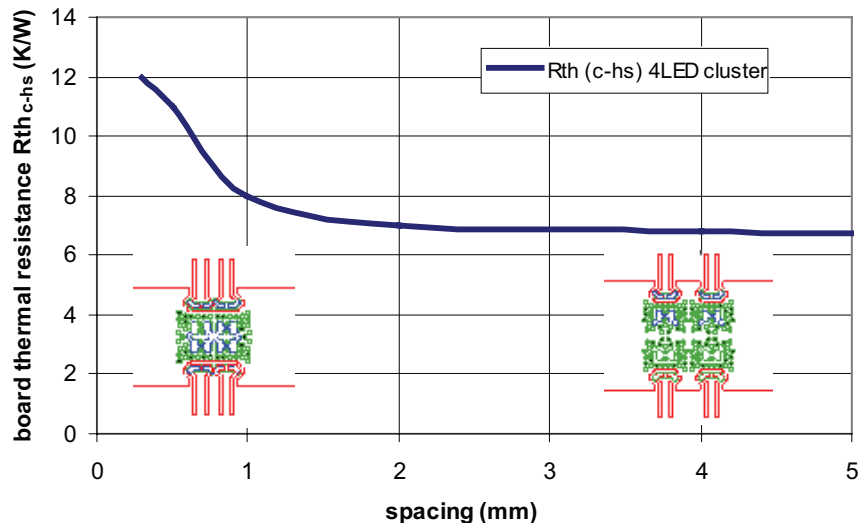

Figure 21. Simulated  $R_{\theta_{c-hs}}$  values for close spacing of LEDs for a two layer FR4 PCB.

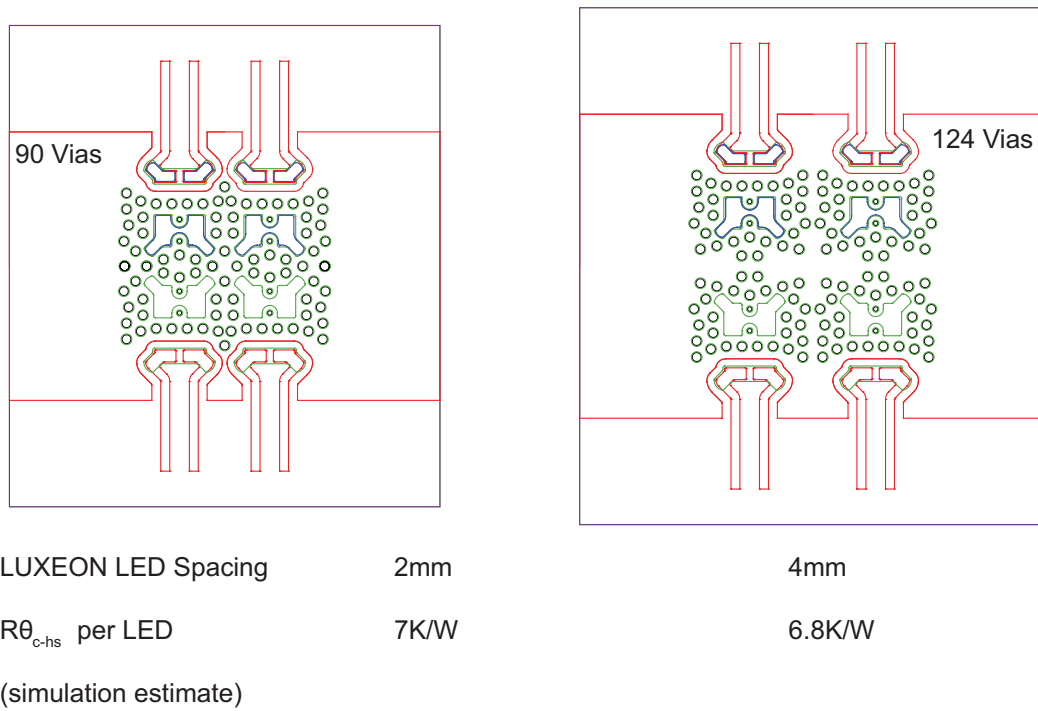

Figure 22. When the edge to edge spacing is reduced from 4 to 2mm, the number of vias decreases from 124 to 90. Thermal resistance values are simulated.

For filled and capped via, a low thermal resistance can be achieved with a minimum component spacing of 0.3mm for a 35µm/70µm (through-hole/total surface) copper plating thickness as shown in Figure 23 (blue line).

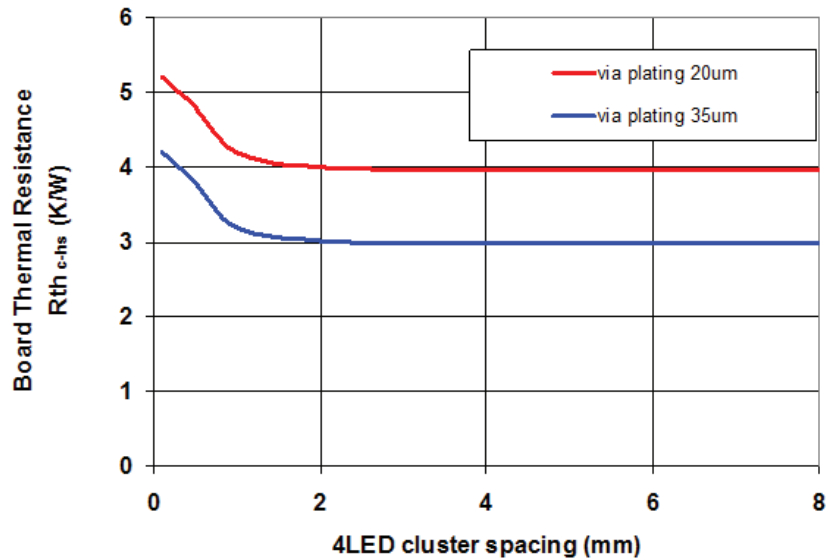

Figure 23.  $R_{th\ c-hs}$  values of the PCB for different LED spacing and different via plating thicknesses.

Figure 24 shows a comparison of the thermal resistance of various board technologies. MCPCB uses 35µm plating, open PTH via board uses 70/35µm copper and filled and capped via board uses 85/35µm copper. Note that the default number of vias is 33 for open PTH and 27 for filled and capped via for 8mm LED spacing. Fewer vias are employed when the LED spacing is reduced which increases the thermal resistance.

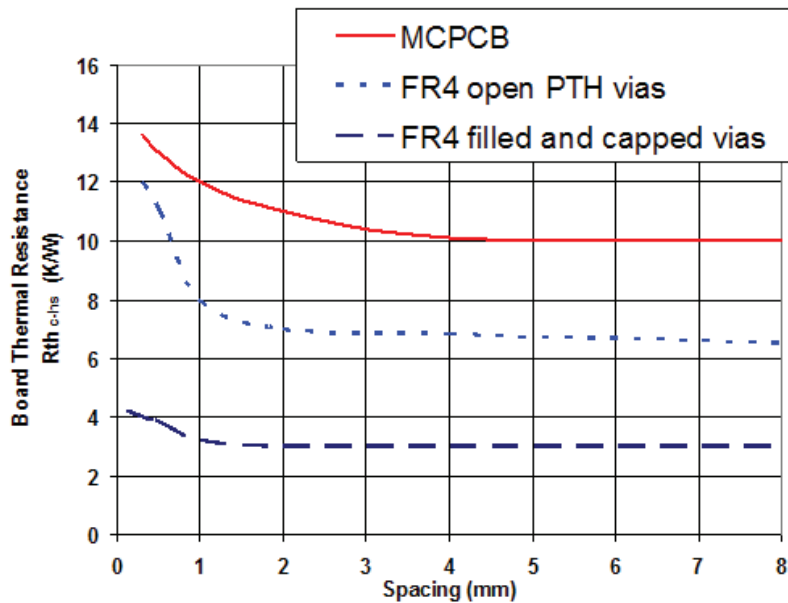

Figure 24. Comparison  $R_{th\ c-hs}$  of various board technologies as a function of LED spacing.

### 3.6 FR4 Board Handling

The substrate of a LUXEON LED is made of ceramic, a relatively brittle material. Even though this product has a small form factor and is unlikely to cause any problems, forces on the package should be kept to a minimum. In particular, excessive bending forces on the package may crack the ceramic substrate or break the solder joints.

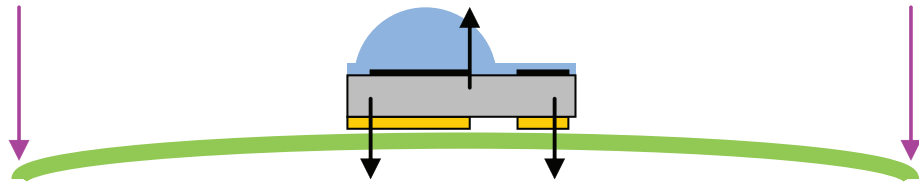

Figure 25. Excessive bending force on the PCB may crack the ceramic substrate of a LUXEON LED and/or damage the solder joints.

Figure 25 shows what forces may, inadvertently, be applied to a LUXEON LED when a flat assembled board is bent. This can happen, for example, when “punching-off” or “breaking-off” LED strips of a PCB panel (Figure 26).

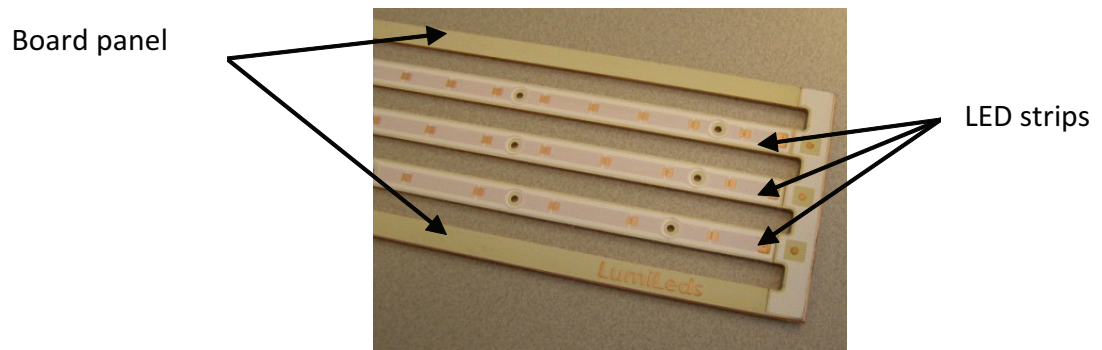

Figure 26. PCB panel consisting of several strips of LEDs.

A printed circuit board may warp after reflow when layers with different CTE (coefficient of thermal expansion) are applied to the top and bottom of the boards. If the PCB is subsequently secured to a flat surface, a vertical force is applied to the ceramic package (see Figure 27). If this force is large enough, the ceramic substrate package may break. To minimize the chance of cracking the ceramic package, orientate the package such that the long side of the package is perpendicular to the dominant warpage direction.

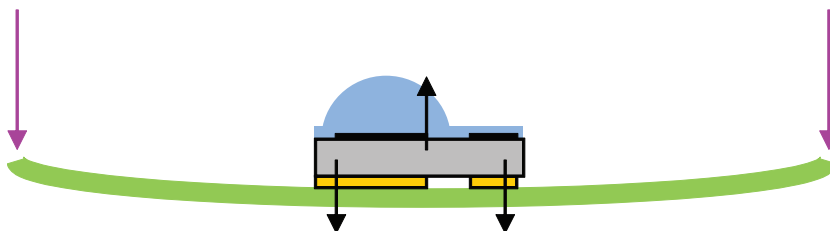

Figure 27. Securing a warped board to flat surface may cause excessive stress on the ceramic substrate.

Board warpage can be minimized by understanding how different CTE materials are stacked up. For example, when an FR4 board is sandwiched between two full copper sheets, adding thin isolation lines in the copper sheet to create copper islands can minimize board warpage as shown in Figure 28.

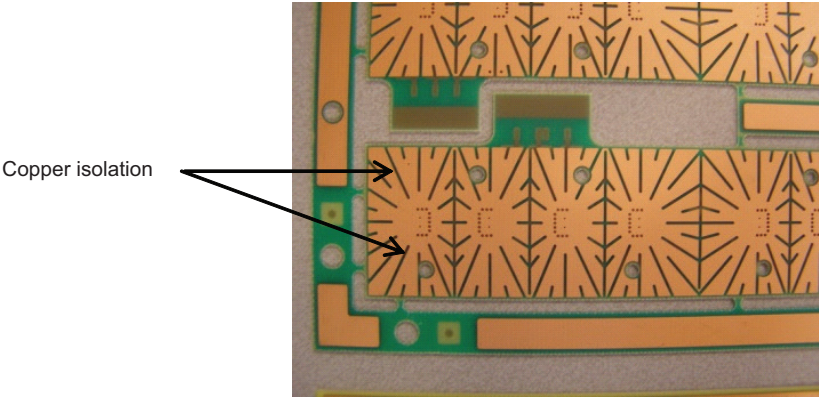

Figure 28. Copper islands can help reduce board warpage.

## 4. MCPCB Board design

The layout for the MCPCB design is similar to the FR4 layout in Figure 8 but without all the vias, see Figure 29.

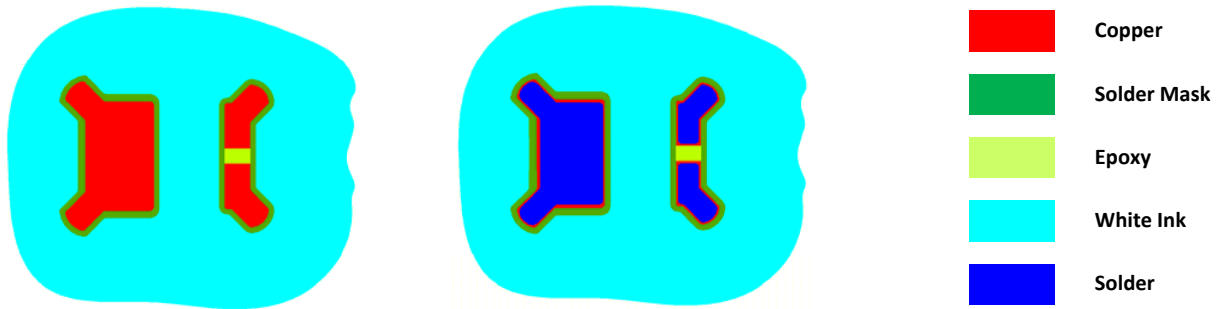

Figure 29. Recommended layout for a LUXEON LED on MCPCB. Note that this layout is similar to the FR4 layout in Figure 8 but without all the vias.

In order to minimize thermal resistance the area of copper connected to the thermal pad of a LUXEON LED must be maximized. Lumileds recommends extending the copper area for the thermal pad 3mm beyond the outline of a LUXEON LED.

A cross section of the MCPCB is shown below.

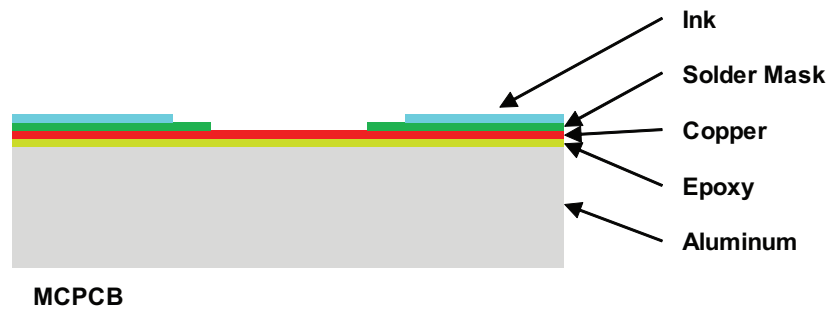

Figure 30. Cross section of MCPCB.

Table 1 summarizes thermal resistance values for typical and high thermal conductivity epoxies. Standard MCPCB design rules yield a board with 10K/W thermal resistance. Increasing the copper thickness and using a thinner dielectric with higher thermal conductivity lowers the thermal resistance dramatically.

In both cases the copper area extending outside the thermal pad is at least 3mm.

**Table 1.**

DIELECTRIC	MCPCB DESIGN PARAMETERS	
	TYPICAL EPOXY	HIGH CONDUCTIVITY EPOXY
Dielectric thermal conductivity [W/mK]	0.8	4
Al thickness [mm]	1.5	1.5
Copper thickness [ $\mu$ m]	30	70
Dielectric thickness [ $\mu$ m]	100	85
Total MCPCB thermal resistance for low density design [K/W]	10	5

The difference between the coefficients of thermal expansion (CTE) of a LUXEON LED and a MCPCB is larger than the difference between the CTE of a LUXEON LED and an FR4 PCB. Therefore, there is greater stress on the solder joint for a LUXEON LED on MCPCB. Studies by Lumileds suggest that dielectric epoxy materials have a strong impact on the solder joint reliability. Lumileds, therefore, recommends that customers contact their MCPCB vendors for suitable dielectric materials.

# 5. Assembly Process Recommendations and Parameters

## 5.1 Stencil Design

The recommended solder stencil thickness is 125µm. The area coverage of the solder paste is greater than 90%. This yields a solder joint thickness of approximately 50µm, using the lead-free solder. Figure 31 shows the recommended stencil design for the footprint with two small thermal vias and solderability indicators for open via PTH board. Figure 32 shows the recommended stencil design for filled and capped via board.

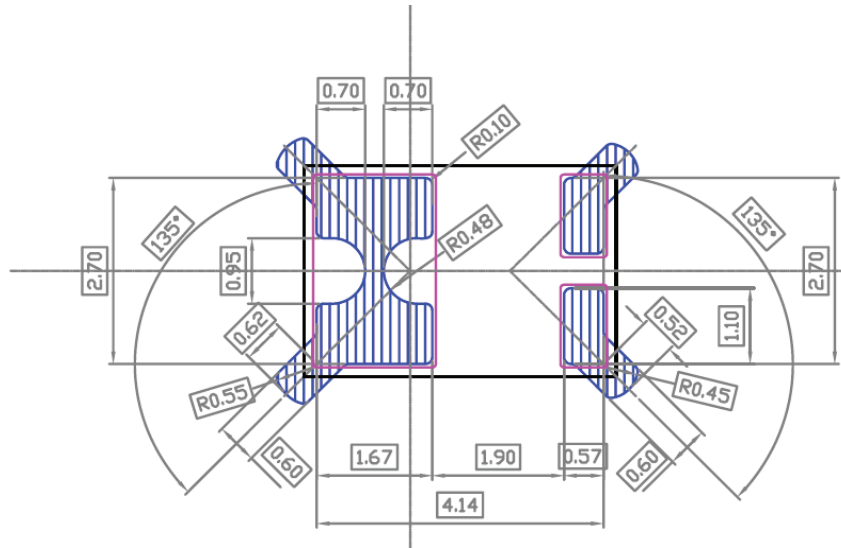

Figure 31. Solder stencil for footprint with two thermal vias and four solder ability indicators.

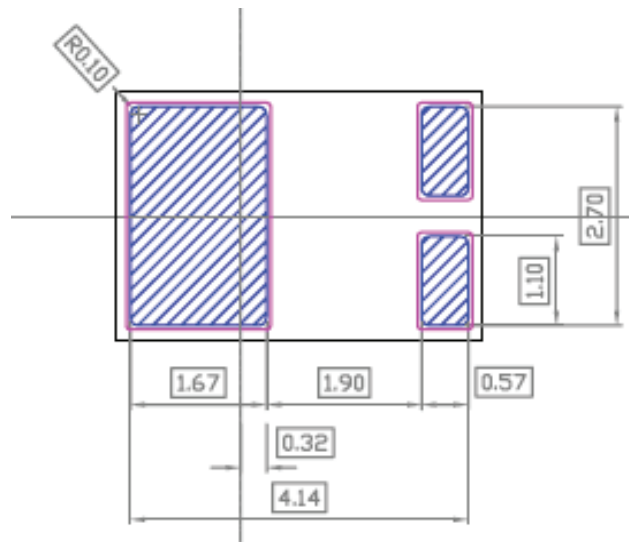

Figure 32. Solder stencil for filled and capped via.

## 5.2 Solder Paste

Lumileds recommends lead-free solder for a LUXEON LED. Lumileds successfully tested SAC 305 solder paste from Alpha Metals (OM338 grade 3 and OM 325 grade 4) with satisfactory results. However, since application environments vary widely, Lumileds recommends that customers perform their own solder paste evaluation in order to ensure it is suitable for the targeted application.

## 5.3 Pick and Place Nozzle

Automated pick and place equipment provides the best placement accuracy for LUXEON LEDs. Since LUXEON LEDs come in two different mechanical configurations (as explained in Section 1.1), Lumileds recommends different pick and place nozzles for each configuration.

Note that pick and place nozzles are customer specific and are typically machined to fit specific pick and place tools. Lumileds has successfully worked with Micro-Mechanics (<http://www.micro-mechanics.com/>) in the past to obtain dedicated pick-up nozzles.

### Pick and place for LUXEON LEDs (configuration A)

A generic nozzle for 0603 components with a pick-up area of 0.95mm x 1.75mm, or a Lumileds specific nozzle can be used for pick and place of LUXEON LEDs (configuration A). Neither nozzle makes any contact with the silicone lens of a LUXEON LED.

Figure 33 shows the typical pick-up area for a 0603 pick-up nozzle overlaid with the footprint of a LUXEON LED (configuration A). Since the outer dimension of 0603 pick-up nozzles may vary between tools and vendors, it's important to verify that the 0603 nozzle does not touch the silicone lens. Using the pattern recognition system of pick and place equipment, the position of the nozzle during pick up is manually programmed. For guidance, the bottom fiducial within the 0603 pick-up area can be used, as shown in Figure 33.

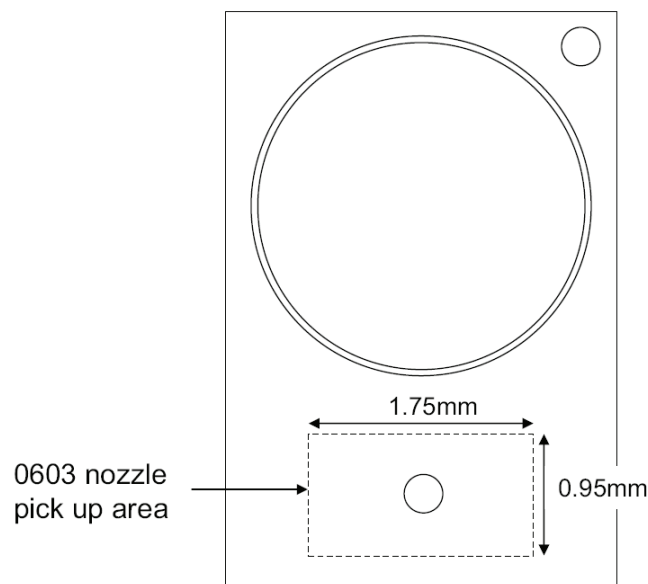

Figure 33. The typical pick up area of a 0603 nozzle, overlaid with the footprint of a LUXEON LED (configuration A).



To prevent the LED from sticking to the nozzle after placement, Lumileds uses the mold release spray SR3-500B from Solent Maintenance.

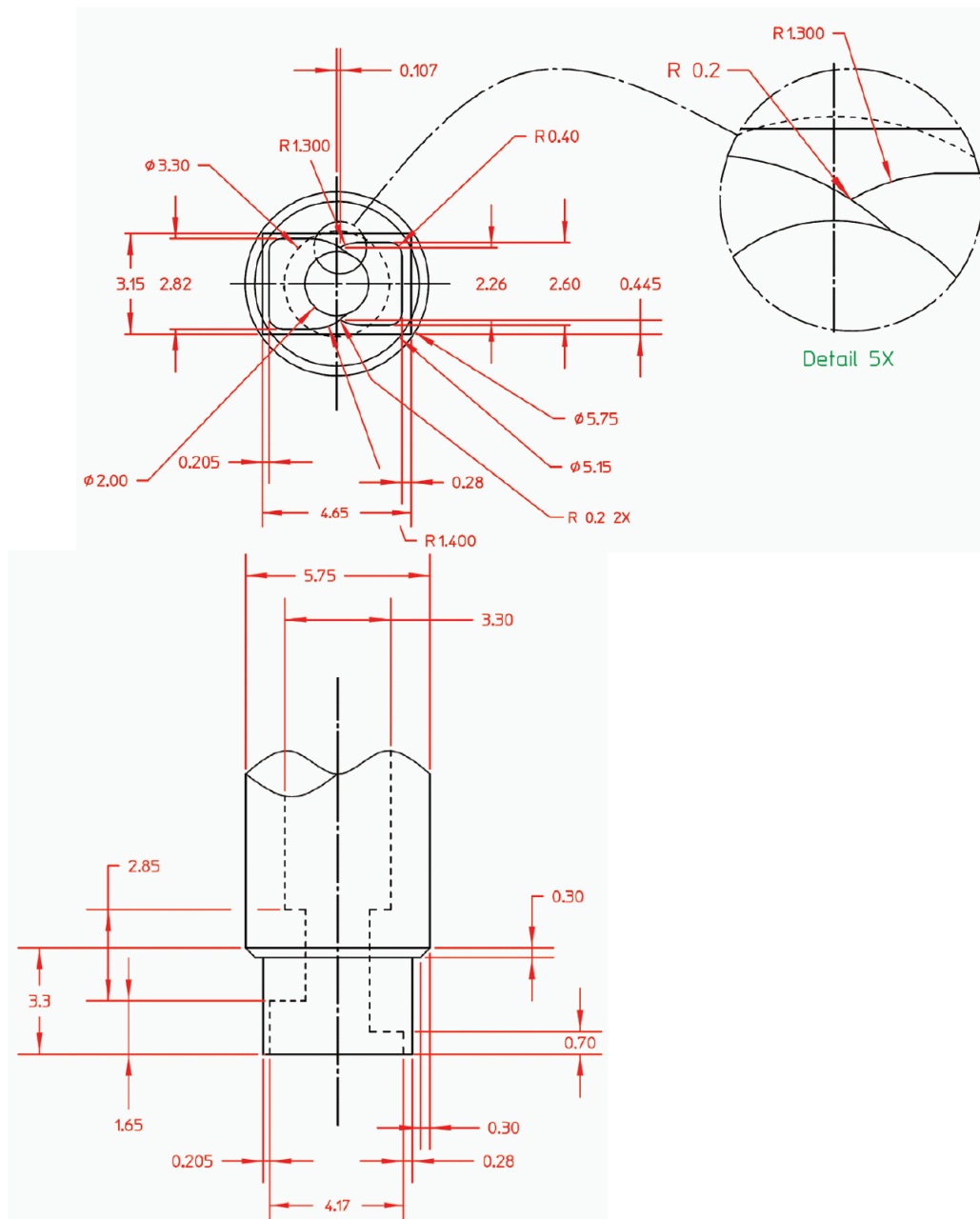

Figure 34. Dedicated pick-up nozzle design for a LUXEON LED (configuration A). The nozzle tolerances must account for the LED dimensions. All dimensions are in mm.

### Pick and place for LUXEON LEDs (configuration B)

A Lumileds specific nozzle can be used for pick and place of LUXEON LEDs (configuration B), see Figure 35. This nozzle picks up from the flat area around the silicone lens and does not make any contact with the silicone lens of a LUXEON LED.

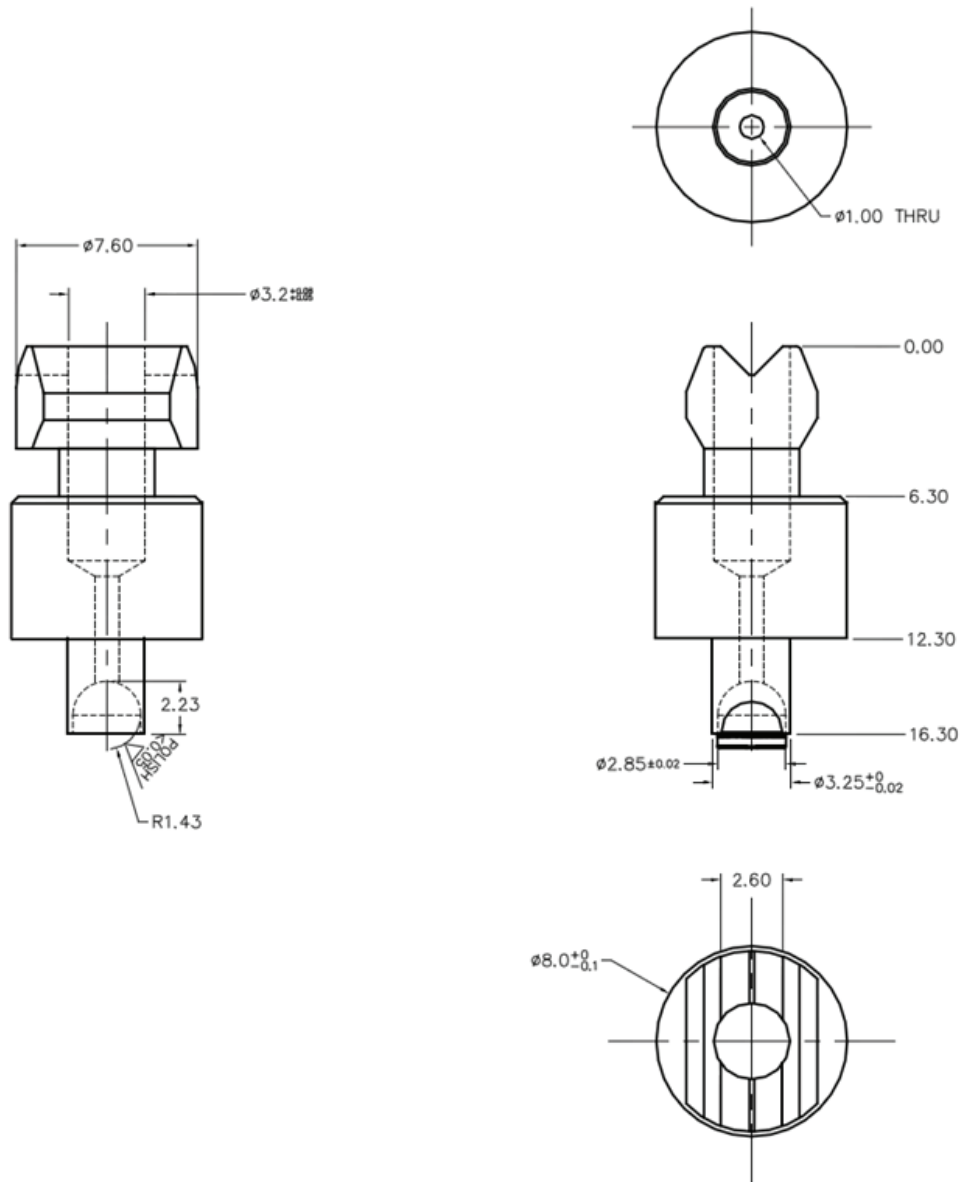

Figure 35. Dedicated pick-up nozzle design for a LUXEON LED (configuration B). This nozzle design, which clears the silicone lens of the LUXEON LED, picks up from the flat area around the silicone lens (see the middle drawing in the right column). All dimensions are in mm.

## 5.4 Pick and Place Machine Optimization

Table 2 below summarizes key pick and place parameters for the dedicated LUXEON LED nozzles based on Lumileds internal test results. Since pick and place settings vary between pick and place tools and vendors, Lumileds recommends that these parameters are used as a reference only.

Table 2.

	LUXEON LED (CONFIGURATION A)	LUXEON LED (CONFIGURATION B)
Pick up location referenced to top of the reel as shown in Figure 36 [mm]	-0.2	-1.6
Vacuum [kPa]	-20	-20
Stencil thickness [micrometer]	125	125
Over travel spring force during placement [N]	2	2
Material	Black anodized aluminum	Stainless steel

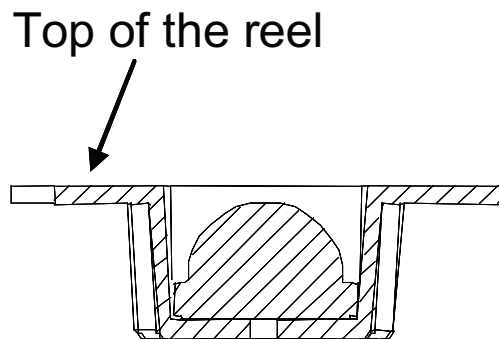
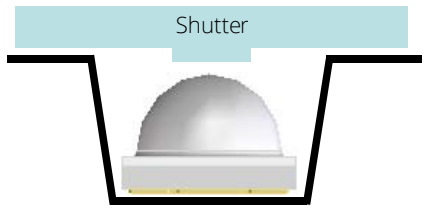
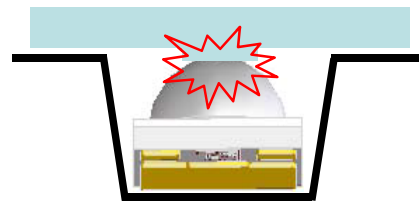

Figure 36. With the top of the reel being 0mm, the nozzle will over travel into the reel by 0.2mm and 1.6mm, respectively, for configuration A and B of the LUXEON LED.

Unlike other SMD electronic components, which generally have cubic shapes, a LUXEON LED has a silicone lens protrusion to enhance light extraction. When the cover tape of the reel is removed, there is a possibility for the silicone lens to touch a part of the sliding/guiding metal plate or the shutter of the feeder during indexing. This can lead to scratched or damaged lenses, see Figure 37.



After the cover tape is removed, the shutter guides the component through the feeder for pick up.



During indexing, the shutter moves back and forth and the component may vibrate. This may cause the silicone lens to come into contact with the shutter.

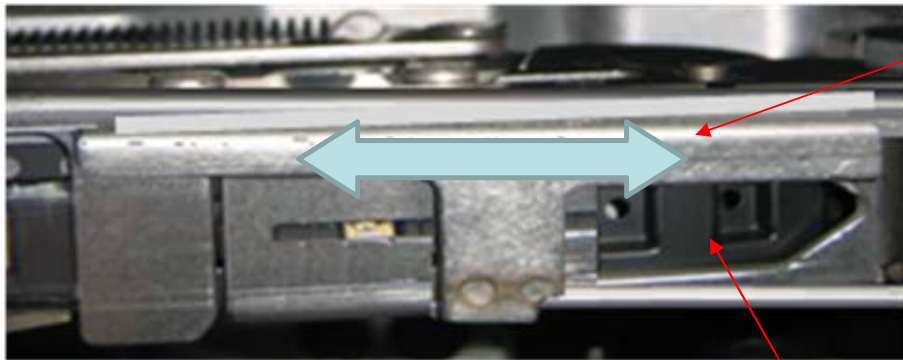

Shutter – slides back and forth during indexing

Pick up nozzle is located here

Figure 37. The silicone lens of a LUXEON LED may be damaged by the cover plate of the pick and place feeder.

In some pick and place machines a simple modification can be made to the pick and place feeder to achieve optimum yield. One recommendation to reduce damage to the silicone lens is to remove the shutter completely and shift the cover tape removal close to the pick-up nozzle. Figure 38 illustrates this recommendation.

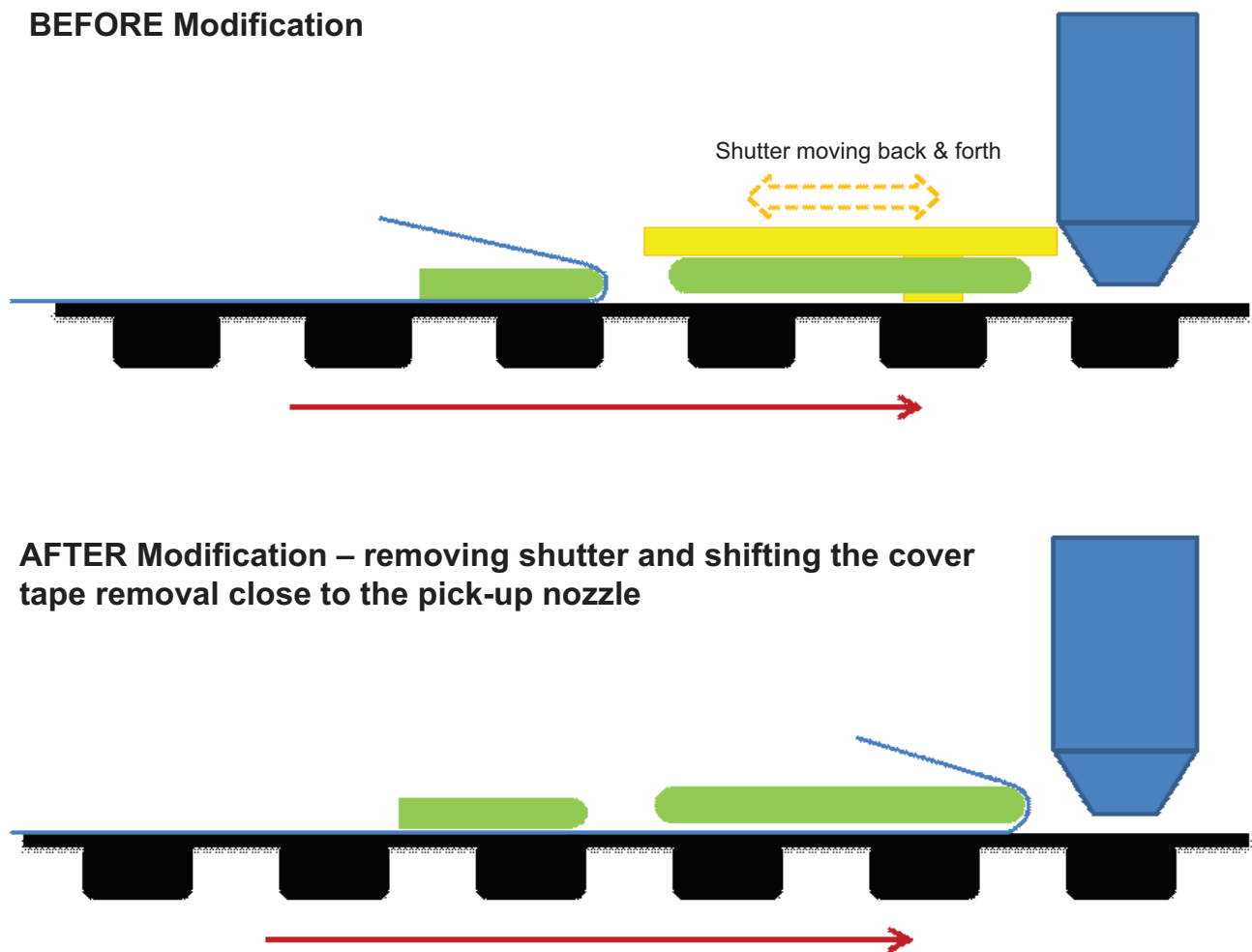

Figure 38. Minor modifications to the pick and place machine minimize the chance of damage to the silicone lens of the LUXEON LED.

In addition to making the above change, Lumileds recommends an electrical (motorized) feeder rather than a mechanical/pneumatic feeder because units can fall out of the tape pocket or become misaligned due to abrupt movements of the tape.

## 5.5 Placement Accuracy

In order to achieve the highest placement accuracy Lumileds recommends using an automated pick and place tool with a vision system that can recognize the bottom metallization of a LUXEON LED (3 pads). If available use the SOT32 profile from the component library, and modify the lead dimensions and pitch according to the dimensions in Figure 39. The recognition tolerance can be set to 30%. A lower percentage improves placement accuracy but may reduce recognition yield.

For high density placement (e.g. spacing between components below 0.5mm) Lumileds recommends using the outline dimensions of a LUXEON LED (see Figure 39) for recognition. Reducing the tolerance on the outline dimensions to 5% eliminates the risk of staggering components.

Lumileds recommends a minimal spacing of 0.3 mm between LUXEON LEDs. This avoids the risk of neighboring components touching each other after reflow. Note, though, that the light output for each LED may drop due to optical absorption between LED packages.

For manual placement, the fiducials on the top side assist in locating the optical center. Figure 2 serves as a guideline to find the optical center on the top side.

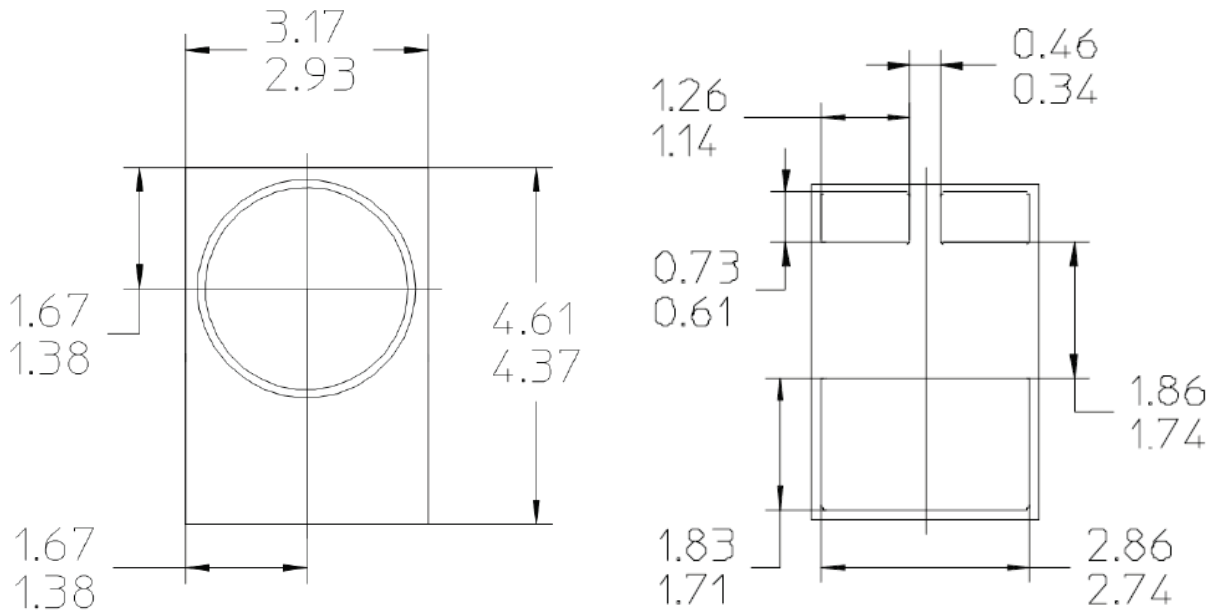

Figure 39. Mechanical dimensions of the LUXEON LED. All dimensions are in mm.

## 5.6 Reflow Profile

LUXEON LEDs are compatible with surface mount technology and lead-free reflow. This greatly simplifies the manufacturing process by eliminating the need for adhesives and epoxies. It has been said that the most important step in reflow soldering is the reflow itself. This occurs when the boards move through the oven and the solder paste melts forming the solder joints. To form good solder joints, the time and temperature profile throughout the reflow process must be well maintained.

A temperature profile consists of three primary phases (an example reflow profile is shown in Figure 40):

1. Preheat: the board enters the reflow oven and is warmed up to a temperature lower than the melting point of the solder alloy.
2. Reflow: the board is heated to a peak temperature above the melting point of the solder, but below the temperature that would damage the components or the board.
3. Cooling down: the board is cooled down rapidly, allowing the solder to freeze, before the board exits the oven.

As a point of reference, the melting temperature for SAC 305 is 217°C, and the minimum peak reflow temperature is 235°C.

Lumileds successfully utilized the reflow profile in Figure 40 for LUXEON LEDs on PCB.

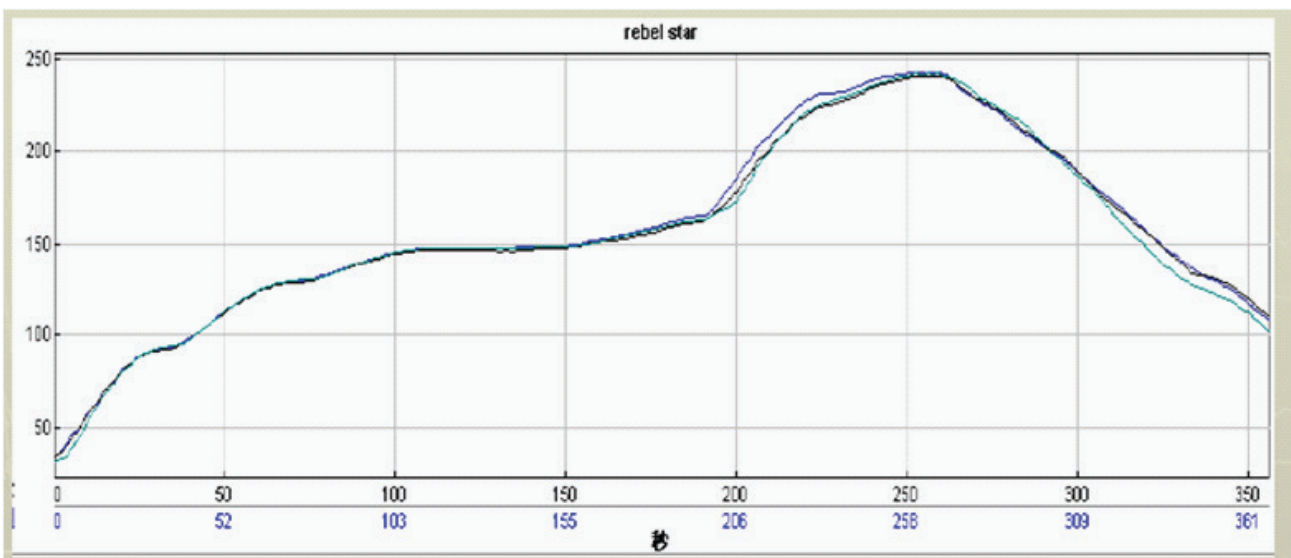

Figure 40. Reflow profile of LUXEON LEDs using SAC-305 solder paste.

## 5.7 Reflow Accuracy

Global fiducials on the PCB board (see Figure 41) can help calculate the reflow accuracy between the centers of the component to the nominal board position. Section 1.2 Optical Center explains how to find the theoretical optical center of the LUXEON LED. Lumileds has determined the placement accuracy after reflow to be well within 90µm in the x and y directions for the footprint of Figure 11. The placement accuracy is determined as follows: The PCB onto which the LUXEON LED is assembled must have fiducials to determine the origin. The position of the LUXEON LED is determined using the component fiducials. The difference between this measured value and the nominal placement position is the placement accuracy.

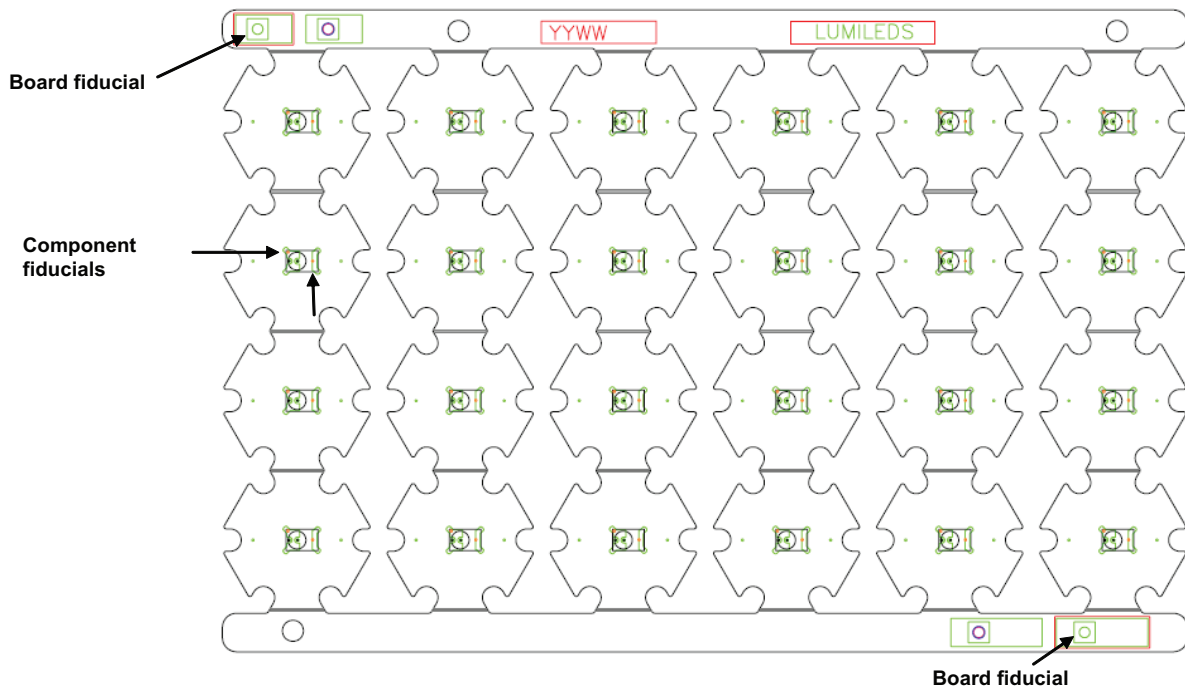

Figure 41. The board fiducials provide the origin of the board.  
The fiducials on a LUXEON LED determine the optical center of the LED.  
The difference between the measured coordinates of the optical center and the nominal position is the placement accuracy.



## 5.8 Void Inspection and Solderability Indicators

An in-line X-Ray machine can inspect for voids after reflow. Lumileds has determined that the two small thermal vias in the thermal pad footprint minimizes voiding by serving as an air vent during reflow.

A large percentage of voids in the thermal pad will increase of the thermal resistance. Figure 42 and Figure 43 show the impact of solder voiding on board thermal resistance ( $R_{\theta_{c-hs}}$ ) based on modeled data.

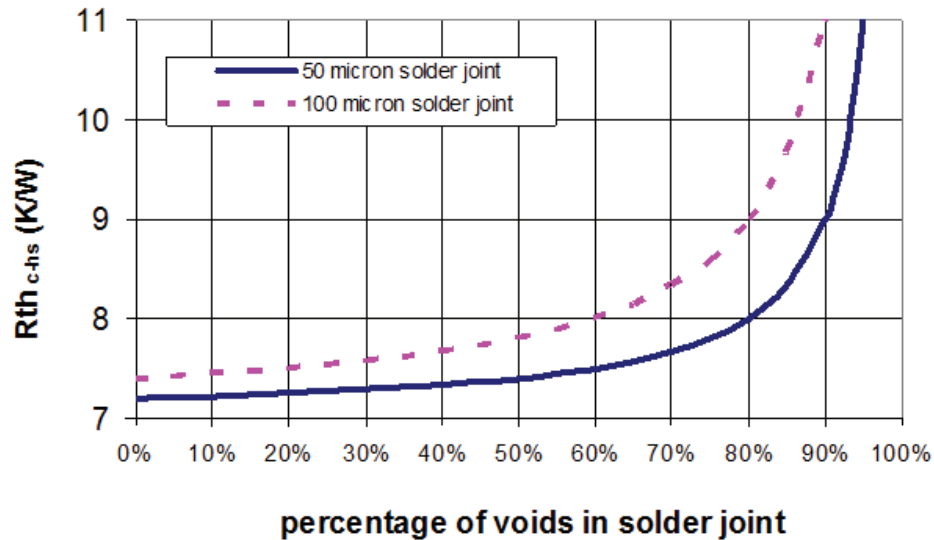

Figure 42. Impact of voiding in thermal land on thermal resistance for open via design.

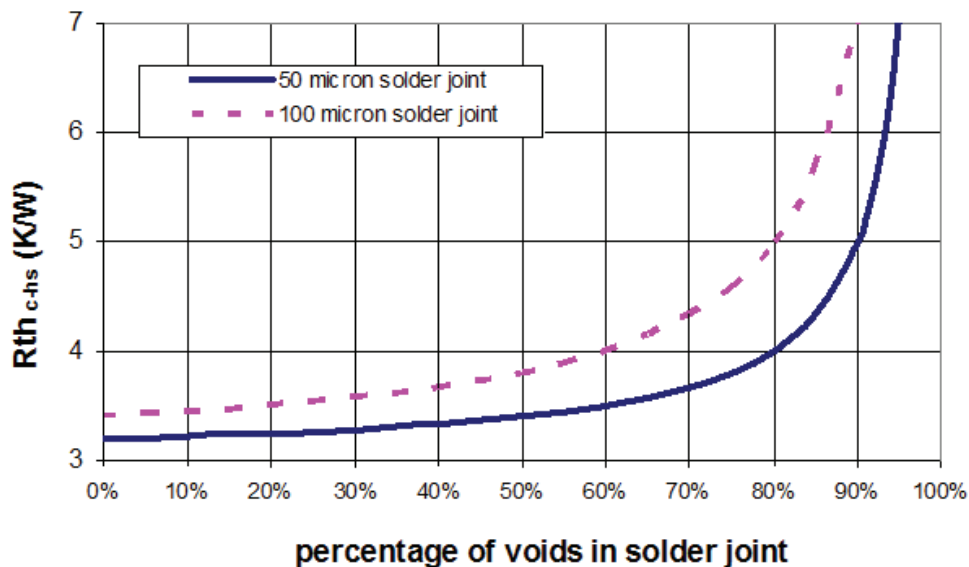

Figure 43. Impact of voiding in thermal land on thermal resistance for filled and capped via design.

For visual inspection of solder wetting, solderability indicators have been designed in the footprint, see Figure 44.

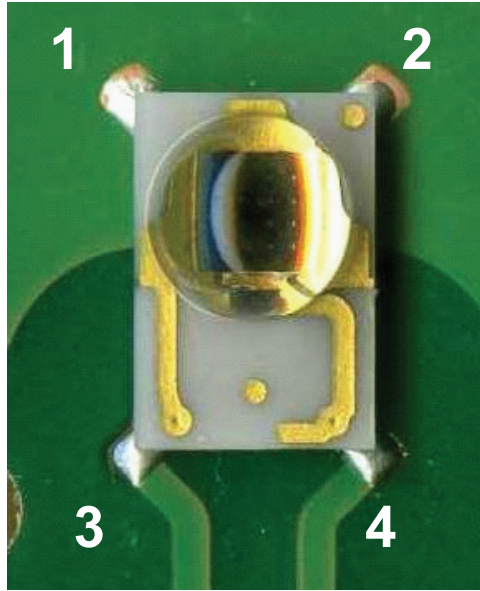

Figure 44. A LUXEON LED reflowed onto an FR4 PCB with four solderability indicators.

## 6. JEDEC Moisture Sensitivity Level

LUXEON LEDs have a JEDEC moisture sensitivity level of 1. This is the highest level offered in the industry and highest level within the JEDEC standard.

This provides the customer with ease of assembly. The customer no longer needs to be concerned about bake out times and floor life. No bake out time is required for a moisture sensitivity level of 1.

Moisture sensitivity level 1 allows the device to be reflowed three times under the specifications as described in the respective LUXEON LED datasheets. JEDEC has defined eight levels for moisture sensitivity, as shown in Table 3.

**Table 3. JEDEC Moisture Sensitivity Levels**

LEVEL	FLOOR LIFE		SOAK REQUIREMENTS			
			STANDARD		ACCELERATED EQUIVALENT <sup>1</sup>	
	TIME	CONDITIONS	TIME (HOURS)	CONDITIONS	TIME (HOURS)	CONDITIONS
1	Unlimited	≤30°C / 85% RH	168 +5/-0	85°C / 85% RH		
2	1 year	≤30°C / 60% RH	168 +5/-0	85°C / 60% RH		
2a	4 weeks	≤30°C / 60% RH	696 <sup>2</sup> +5/-0	30°C / 60% RH	120 +1/-0	60°C / 60% RH
3	168 hours	≤30°C / 60% RH	192 <sup>2</sup> +5/-0	30°C / 60% RH	40 +1/-0	60°C / 60% RH
4	72 hours	≤30°C / 60% RH	96 <sup>2</sup> +2/-0	30°C / 60% RH	20 +0.5/-0	60°C / 60% RH
5	48 hours	≤30°C / 60% RH	72 <sup>2</sup> +2/-0	30°C / 60% RH	15 +0.5/-0	60°C / 60% RH
5a	24 hours	≤30°C / 60% RH	48 <sup>2</sup> +2/-0	30°C / 60% RH	10 +0.5/-0	60°C / 60% RH
6	Time on Label (TOL)	≤30°C / 60% RH	TOL	30°C / 60% RH		

## 7. Product Packaging Considerations — Chemical Compatibility

LUXEON LEDs contain a silicone overcoat and silicone lens to protect the LED chip and extract the maximum amount of light. As with most silicones used in LED optics, care must be taken to prevent any incompatible chemicals from directly or indirectly reacting with the silicone.

The silicone overcoat in the LUXEON LED is gas permeable. Consequently, oxygen and volatile organic compound (VOC) gas molecules can diffuse into the silicone overcoat. VOCs may originate from adhesives, solder fluxes, conformal coating materials, potting materials and even some of the inks that are used to print the PCBs.

Some VOCs and chemicals react with silicone and produce discoloration and surface damage. Other VOCs do not chemically react with the silicone material directly but diffuse into the silicone and oxidize during the presence of heat or light. Regardless of the physical mechanism, both cases may affect the total LED light output. Since silicone permeability increases with temperature, more VOCs may diffuse into and/or evaporate out from the silicone.

Careful consideration must be given to whether LUXEON LEDs are enclosed in an “air tight” environment or not. In an “air tight” environment, some VOCs that were introduced during assembly may permeate and remain in the silicone lens. Under heat and “blue” light, the VOCs inside the silicone lens may partially oxidize and create a silicone discoloration, particularly on the surface of the LED where the flux energy is the highest. In an air rich or “open” air environment, VOCs have a chance to leave the area (driven by the normal air flow). Transferring the devices which were discolored in the enclosed environment back to “open” air may allow the oxidized VOCs to diffuse out of the silicone lens and may restore the original optical properties of the LED.

Determining suitable threshold limits for the presence of VOCs is very difficult since these limits depend on the type of enclosure used to house the LEDs and the operating temperatures. Also, some VOCs can photo-degrade over time.

Table 4 provides a list of commonly used chemicals that should be avoided as they may react with the silicone material. Note that Lumileds does not warrant that this list is exhaustive since it is impossible to determine all chemicals which may affect the performance of LUXEON LEDs.

**Table 4. List of commonly used chemicals that will damage the silicone lens of a LUXEON LED. Avoid using any of these chemicals in the housing that contains the LED package.**

CHEMICAL NAME	NORMALLY USED AS
Hydrochloric acid	acid
Sulfuric acid	acid
Nitric acid	acid
Acetic acid	acid
Sodium hydroxide	alkali
potassium hydroxide	alkali
Ammonia	alkali
MEK (Methyl Ethyl Ketone)	solvent
MIBK (Methyl Isobutyl Ketone)	solvent
Toluene	solvent
Xylene	solvent
Benzene	solvent
Gasoline	solvent
Mineral spirits	solvent
Dichloromethane	solvent
Tetrachlorometane	solvent
Castor oil	oil
Lard	oil
Linseed oil	oil
Petroleum	oil
Silicone oil	oil
Halogenated hydrocarbons (containing F, Cl, Br elements)	misc
Rosin flux	solder flux
Acrylic tape	adhesive

The chemicals in Table 4 are typically not directly used in the final products that are built around LUXEON LEDs. However, some of these chemicals may be used in intermediate manufacturing steps (e.g. cleaning agents). Consequently, trace amounts of these chemicals may remain on (sub)components, such as PCBs. Lumileds, therefore, recommends the following precautions when designing your application:

- When designing secondary lenses to be used over a single LED, provide a sufficiently large air-pocket and allow for “ventilation” of this air away from the immediate vicinity of the LED.
- Use mechanical means of attaching lenses and circuit boards as much as possible. When using adhesives, potting compounds and coatings, carefully analyze its material composition and do thorough testing of the entire fixture under High Temperature over Life (HTOL) conditions.

## About Lumileds

Lumileds is the global leader in light engine technology. The company develops, manufactures and distributes groundbreaking LEDs and automotive lighting products that shatter the status quo and help customers gain and maintain a competitive edge.

With a rich history of industry “firsts,” Lumileds is uniquely positioned to deliver lighting advancements well into the future by maintaining an unwavering focus on quality, innovation and reliability.

To learn more about our portfolio of light engines, visit [lumileds.com](http://lumileds.com).



©2016 Lumileds Holding B.V. All rights reserved.  
LUXEON is a registered trademark of the Lumileds Holding B.V.  
in the United States and other countries.

[lumileds.com](http://lumileds.com)

Neither Lumileds Holding B.V. nor its affiliates shall be liable for any kind of loss of data or any other damages, direct, indirect or consequential, resulting from the use of the provided information and data. Although Lumileds Holding B.V. and/or its affiliates have attempted to provide the most accurate information and data, the materials and services information and data are provided “as is,” and neither Lumileds Holding B.V. nor its affiliates warrants or guarantees the contents and correctness of the provided information and data. Lumileds Holding B.V. and its affiliates reserve the right to make changes without notice. You as user agree to this disclaimer and user agreement with the download or use of the provided materials, information and data.