



LUXEON CoB Core Pro

Perfect for high-end retail and hospitality



Retail and hospitality lighting needs are crystal clear: very high efficacy and excellent quality of light that makes colors pop and encourages customers to engage with displays and products. LUXEON CoB Core Pro delivers the light and efficacy along with long-life and color stability for high value installations.

FEATURES AND BENEFITS

- Best in class efficacy and superior color quality
- Multiple LES sizes and flux output that fit different applications and requirements
- Superior thermal resistance enabling the use of smaller heatsinks and prolonged product life span
- Supported by a comprehensive optical, mechanical, and electrical ecosystem

PRIMARY APPLICATIONS

- Spotlights
- Track Lights
- Downlights
- Low Bay

LUXEON CoB Core Pro product performance at specified test current, $T_j=85^\circ\text{C}$.

LES ^[4] (mm)	NOMINAL CCT	MINIMUM CRI ^[1, 2, 3]	LUMINOUS FLUX ^[1] (lm)		TYPICAL LUMINOUS EFFICACY (lm/W)	TEST CURRENT (mA)	ENERGY EFFICIENCY CLASS ^[5]	PART NUMBER
			MINIMUM	TYPICAL				
9	3000K	90	729	810	117	200	F	L2C5-30901202X09B0
9	3000K	90	1210	1344	130	300	E	L2C5-30901203X09B0
13	3000K	90	2462	2735	130	600	E	L2C5-30901205X13B0
15	3000K	90	3676	4084	130	900	E	L2C5-30901208X15B0
15	3000K	90	3780	4200	134	900	E	L2C5-30901208X15B1
15	3000K	90	3879	4310	141	900	E	L2C5-30901210X15B0
19	3000K	90	4959	5510	132	1200	E	L2C5-30901211X19B0

Notes :

1. Lumileds maintains a tolerance of ± 2 on CRI and $\pm 6.5\%$ on luminous flux measurements.
2. Typical CRI is approximately 2 points higher than the minimum CRI specified, but this is not guaranteed.
3. R9 value of 90CRI products is >50 .
4. Light Emitting Surface (LES) is the inner diameter (phosphor area) inside the dam.
5. Energy efficiency class as specified in Commission Delegated Regulation (EU) 2019/2015. The available range of energy efficiency classes is A-G.

Mechanical Dimensions.

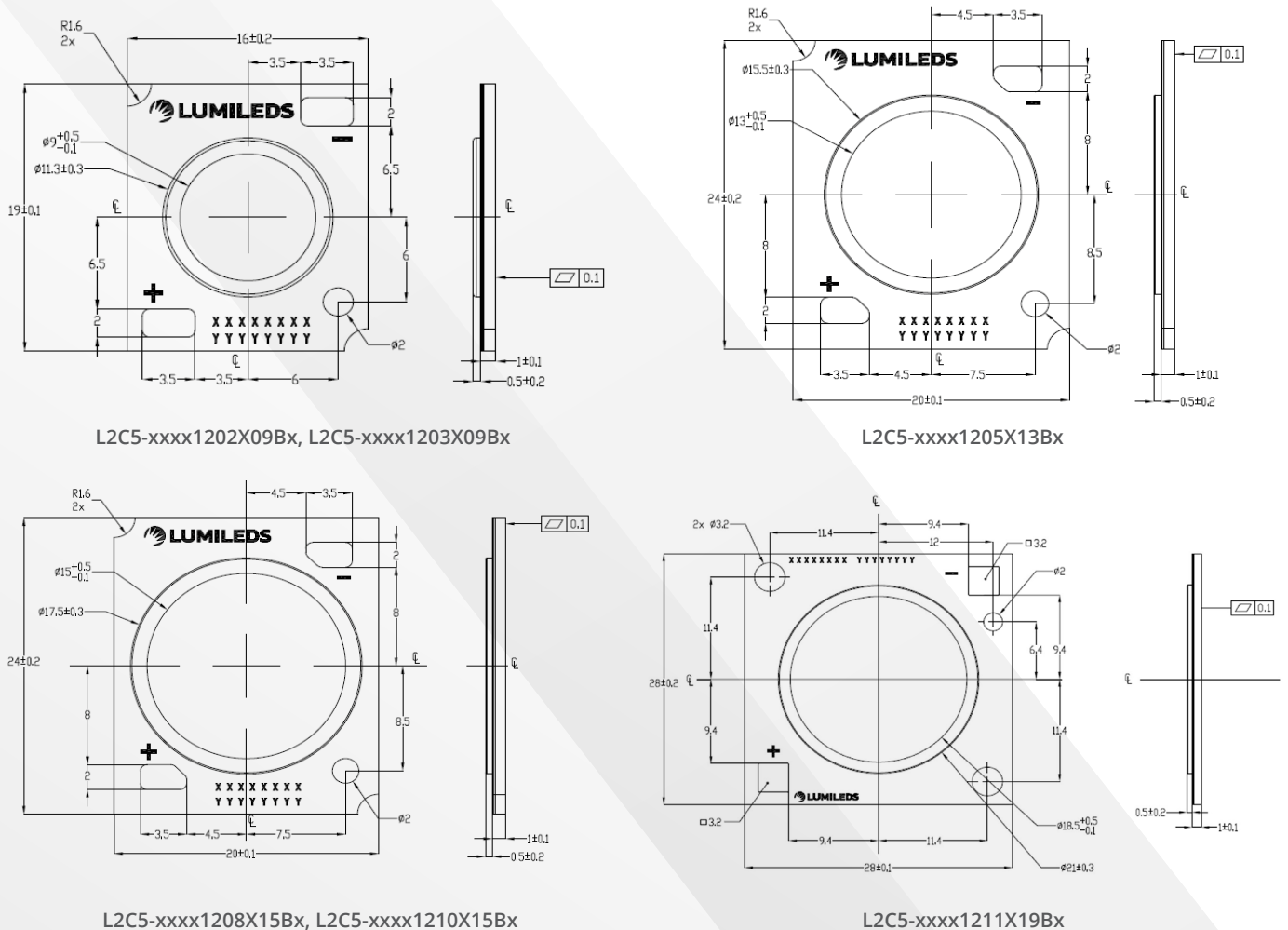

Notes:

1. Drawings are not to scale.
2. All dimensions are in millimeters.

©2022 Lumileds Holding B.V. All rights reserved. LUXEON is a registered trademark of the Lumileds Holding B.V. in the United States and other countries.

lumileds.com

Neither Lumileds Holding B.V. nor its affiliates shall be liable for any kind of loss of data or any other damages, direct, indirect or consequential, resulting from the use of the provided information and data. Although Lumileds Holding B.V. and/or its affiliates have attempted to provide the most accurate information and data, the materials and services information and data are provided "as is," and neither Lumileds Holding B.V. nor its affiliates warrants or guarantees the contents and correctness of the provided information and data. Lumileds Holding B.V. and its affiliates reserve the right to make changes without notice. You as user agree to this disclaimer and user agreement with the download or use of the provided materials, information and data. A listing of Lumileds product/patent coverage may be accessed at lumileds.com/patents.