

# LUXEON 3030 Line

## Assembly and Handling Information



### Introduction

This application brief addresses the recommended assembly and handling guidelines for LUXEON 3030 emitters. These emitters deliver high efficacy and quality of light for distributed light source applications in a compact 3.0mm x 3.0mm package. Proper assembly, handling, and thermal management, as outlined in this application brief, ensure high optical output and reliability of these emitters.

### Scope

The assembly and handling guidelines in this application brief apply to the following LUXEON products:

PRODUCTS
LUXEON 3030 2D
LUXEON 3030 HE Plus
LUXEON 3030 HV

In the remainder of this document the term LUXEON emitter or LUXEON 3030 refers to any product in the LUXEON series listed above.

# Table of Contents

Introduction .....	1
Scope .....	1
<b>1. Component .....</b>	<b>3</b>
1.1 Description .....	3
1.2 Optical Center .....	3
1.3 Handling Precautions .....	3
1.4 Cleaning .....	3
1.5 Electrical Isolation .....	4
1.6 Mechanical Files .....	4
<b>2. PCB Design Guidelines for the LUXEON Emitter .....</b>	<b>4</b>
2.1 PCB Footprint and Land Pattern .....	4
2.2 Surface Finishing .....	4
2.3 Minimum Spacing .....	4
<b>3. Thermal Management .....</b>	<b>5</b>
<b>4. Thermal Measurement Guidelines .....</b>	<b>7</b>
<b>5. Assembly Process Guidelines .....</b>	<b>8</b>
5.1 Stencil Design .....	8
5.2 Solder Paste .....	8
5.3 Solder Reflow Profile .....	8
5.4 Pick and Place .....	8
5.5 Electrostatic Discharge Protection .....	9
5.6 JEDEC Moisture Sensitivity .....	9
<b>6. Packaging Considerations—Chemical Compatibility .....</b>	<b>10</b>
About Lumileds .....	12

# 1. Component

## 1.1 Description

The LUXEON emitter (Figure 1) is an EMC (epoxy molding compound) molded, no-lead, surface mount package consisting of an anode and a cathode. A small circle, or a chamfer, on the corner of the package marks the cathode side of the emitter package. Majority of the heat is being dissipated through the larger pad (cathode). The LUXEON emitter does not include any transient voltage suppressor (TVS) chip to protect the emitter against electrostatic discharges (ESD). Appropriate precautions should therefore be taken when handling this device (see Section 5.5).

## 1.2 Optical Center

The optical center coincides with the mechanical center of the LUXEON emitter. Optical rayset data for the LUXEON emitter are available at [lumileds.com](http://lumileds.com).

## 1.3 Handling Precautions

The LUXEON emitter is designed to maximize light output and reliability. However, improper handling of the device may damage the silicone encapsulation and affect the overall performance and reliability. In order to minimize the risk of damage to the silicone encapsulation during handling, the LUXEON emitter should only be picked up from the side of the package (Figure 2).

## 1.4 Cleaning

The LUXEON emitter should not be exposed to dust and debris. Excessive dust and debris may cause a drastic decrease in optical output. In the event that a LUXEON emitter requires cleaning, first try a gentle swabbing using a lint-free swab. If needed, a lint-free swab and isopropyl alcohol (IPA) can be used to gently remove dirt from the silicone coating. Do not use other solvents as they may adversely react with the package of the LUXEON emitter. For more information regarding chemical compatibility, see Section 6.

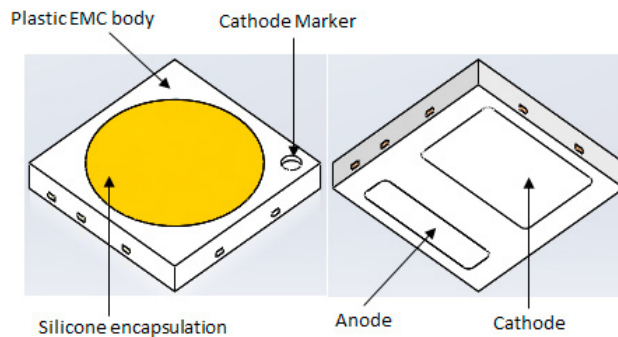

Figure 1. Package rendering of a representative LUXEON 3030 emitter.

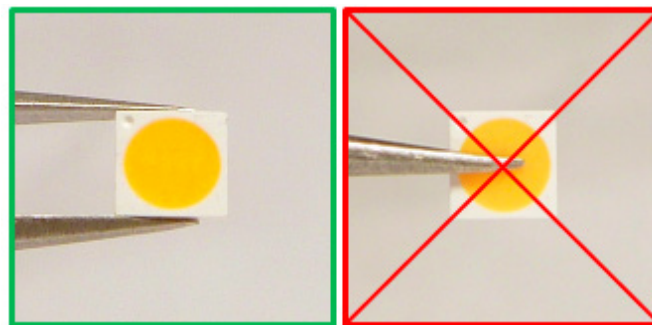

Figure 2. Correct handling (left) and incorrect handling (right) of LUXEON emitters.

## 1.5 Electrical Isolation

The LUXEON emitter contains two electrode pads on the package. It is important to keep sufficient distance between the LUXEON emitter package and any other objects or neighboring LUXEON emitters to prevent any accidental shorts.

In order to avoid any electrical shocks, flashover and/or damage to the LUXEON emitter, each design needs to comply with the appropriate standards of safety and isolation distances, known as clearance and creepage distances, respectively (e.g. IEC60950, clause 2.10.4).

## 1.6 Mechanical Files

Mechanical drawings for the LUXEON emitter are available at [lumileds.com](http://lumileds.com).

# 2. PCB Design Guidelines for the LUXEON Emitter

The LUXEON emitter is designed to be soldered onto a Printed Circuit Board (PCB). To ensure optimal operation, the PCB should be designed to minimize the overall thermal resistance between the LED package and the heat sink.

## 2.1 PCB Footprint and Land Pattern

The recommended PCB footprint design for the LUXEON emitter is shown in Figure 3. In order to ensure proper heat dissipation from the emitter electrodes to the PCB, it is best to extend the top copper layer of the PCB beyond the perimeter of the LUXEON emitter by at least 4mm (see Section 3).

## 2.2 Surface Finishing

Lumileds recommends using a high temperature organic solderability preservative (OSP) or electroless nickel immersion gold (ENIG) plating on the exposed copper pads.

## 2.3 Minimum Spacing

Lumileds recommends a minimum edge to edge spacing between LUXEON emitters of 0.5mm. Placing multiple LUXEON emitters too close to each other may adversely impact the ability of the PCB to dissipate the heat from the emitters.

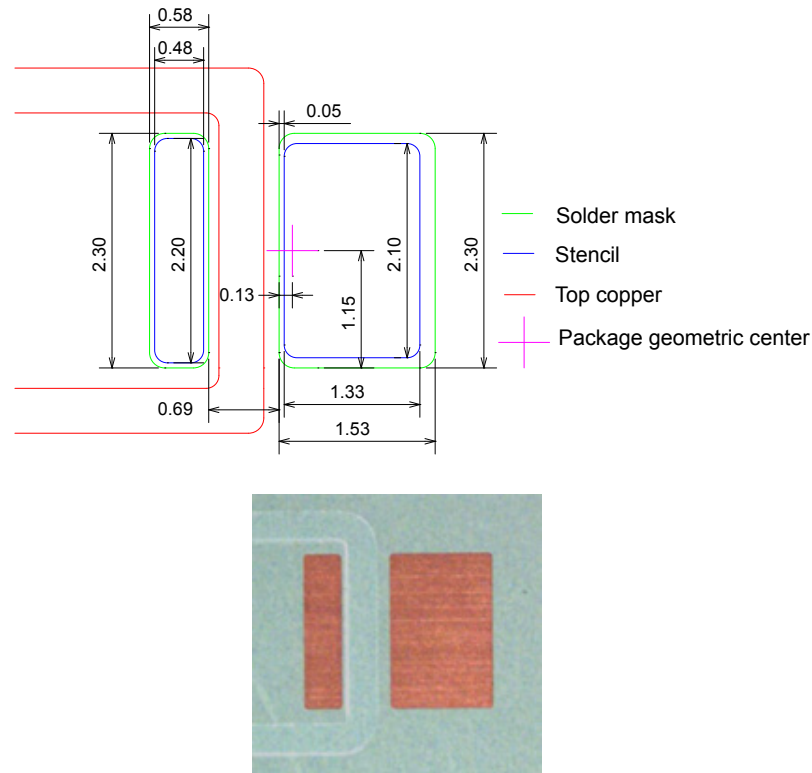

Figure 3. Recommended PCB footprint design for the LUXEON emitter (top). In order to ensure proper heat dissipation from the package electrodes to the PCB, it is best to extend the top copper layer of the PCB several millimeters beyond the package of the LUXEON emitter. See Section 3 for more information on the copper layout. All dimensions are in mm. Bottom picture shows the actual FR4 PCB footprint layout.

### 3. Thermal Management

The overall thermal resistance between a LUXEON emitter and the heat sink is strongly affected by the design and material of the PCB on which the emitter is soldered. Metal Core PCBs have been historically used in the LED industry for their low thermal resistance and rigidity. However, MCPCBs may not always offer the most economical solution. Multi-layer epoxy FR4 PCBs are commonly used in the electronics industry and can, if properly designed, yield an appropriate low-cost solution for various LED applications.

Lumileds investigated the thermal performance of LUXEON emitters on a 1.0mm thick FR4 PCB with a top copper plating of 35µm (single sided copper layer PCB). In order to quantify the impact of the top copper metallization design layout on the overall thermal resistance between junction and heat sink, two designs with varying copper trace layout around the anode and cathode were evaluated as shown in Table 1. The two designs are:

- a. A – Minimum top copper corresponds to copper trace which extends beyond the outline of the LUXEON emitter package by 0.25mm which corresponds to half of the minimum recommended package to package spacing of 0.5mm. This configuration is representative of worst case condition for application where multiple LEDs are placed in close proximity to each other.
- b. B – Maximize top copper around the cathode as much as possible. This is the ideal layout for FR4 PCB since the primary heat flow of the LUXEON emitter is through the cathode pad as described in section 1.1.

As general guidelines, increasing the top copper thickness and increasing the copper area around the cathode will reduce the FR4 board thermal resistance. Adding a bottom copper layer to the FR4 (double sided copper clad PCB) does not reduce the FR4 thermal resistance since the FR4 material itself is a poor thermal conductor.

Table 1. Typical thermal resistance values for FR4 PCBs with varying top copper trace pattern (solid red area). Design B yields the lowest board thermal resistance.

DESIGN	TYPICAL $R_{\theta_{j-BOTTOM PCB}}$ [K/W]	TYPICAL $R_{\theta_{j-S}}$ [K/W]
<p><b>A</b> (mimimum copper pattern, 0.25mm around package outline)</p> 	74	18
<p><b>B</b> (maximize copper around cathode pad)</p> 	32	12

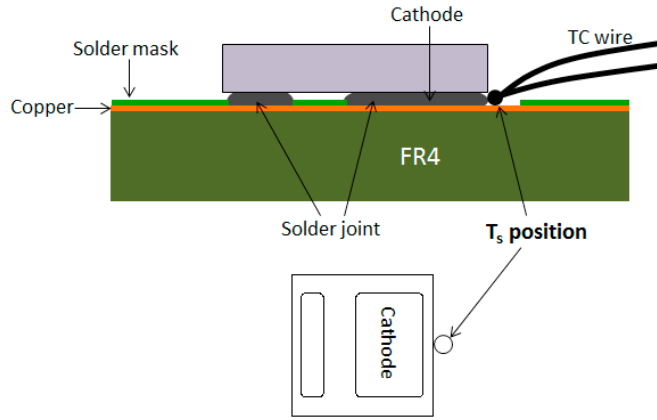

Figure 4. The recommended temperature measurement point  $T_s$  is located on the cathode copper layer of the PCB, closest to the package. The picture above shows where to place the welding tip of the TC wire prior to dispensing any thermal conductive epoxy to secure the TC wire.

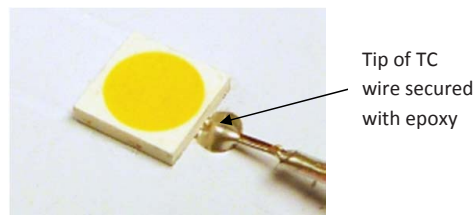

Figure 5. Photo showing actual placement of TC wire secured with thermal conductive epoxy. The thermal epoxy volume should be kept to minimum as shown.

## 4. Thermal Measurement Guidelines

The typical thermal resistance  $R\theta_{j-case}$  between the junction and the solder pads of the LUXEON emitter is provided in the datasheet. With this information, the junction temperature  $T_j$  can be determined according to the following equation:

$$T_j = T_{thermal\ pad} + R\theta_{j-thermal\ pad} \cdot P_{electrical}$$

In this equation  $T_{case}$  is the temperature at the bottom of the solder pads of the LUXEON emitter and  $P_{electrical}$  is the electrical power going into the emitter. In typical applications it may be difficult, though, to measure the temperature  $T_{case}$  directly. Therefore, a practical way to determine the junction temperature of the LUXEON emitter is by measuring the temperature  $T_s$  of a predetermined sensor pad on the PCB with a thermocouple.

The recommended location of the sensor pad is right next to the cathode of the LUXEON emitter on the PCB, as shown in Figure 4 and Figure 5. To ensure accurate reading, the thermocouple (TC) tip must make direct contact to the copper of the PCB onto which the LUXEON emitter cathode pad is soldered, i.e. any solder mask or other masking layer must be first removed before mounting the thermocouple onto the PCB. The tip of the TC wire where two dissimilar metals are welded should be placed as close as possible to the LUXEON emitter package on the exposed cathode copper layer as shown in Figure 4. The thermal resistance  $R\theta_{j-s}$  between the sensor pad and the LUXEON emitter junction was experimentally determined on FR4 PCBs for the two different designs (see Table 1). The junction temperature can then be calculated as follows:

$$T_j = T_s + R\theta_{j-s} \cdot P_{electrical}$$

It is recommended to secure the tip of TC wire to the exposed copper area with a good thermal conductive epoxy such as Artic Silver™ thermal adhesive. Note that the Artic Silver™ epoxy is not formulated to conduct electricity. During dispensing of epoxy, avoid flooding the TC wire with too much epoxy but sufficient enough to secure the TC wire for measurement. Putting more epoxy than needed may change the thermal behavior of the surrounding area.

## 5. Assembly Process Guidelines

### 5.1 Stencil Design

The recommended solder stencil thickness is 127µm or 5mils.

### 5.2 Solder Paste

Lumileds recommends lead-free solder for the LUXEON emitter such as SAC 305 solder paste from Alpha Metals (SAC305-CVP390-M20 type 3). However, since application environments vary widely, Lumileds recommends that customers perform their own solder paste evaluation in order to ensure it is suitable for the targeted application.

### 5.3 Solder Reflow Profile

The LUXEON emitter is compatible with standard surface-mount and lead-free reflow technologies. This greatly simplifies the manufacturing process by eliminating the need for adhesives and epoxies. The reflow step itself is the most critical step in the reflow soldering process and occurs when the boards move through the oven and the solder paste melts, forming the solder joints. To form good solder joints, the time and temperature profile throughout the reflow process must be well maintained.

A temperature profile consists of three primary phases:

1. Preheat: the board enters the reflow oven and is warmed up to a temperature lower than the melting point of the solder alloy.
2. Reflow: the board is heated to a peak temperature above the melting point of the solder, but below the temperature that would damage the components or the board.
3. Cool down: the board is cooled down rapidly, allowing the solder to freeze, before the board exits the oven.

As a point of reference, the melting temperature for SAC 305 is 217°C, and the minimum peak reflow temperature is 235°C.

### 5.4 Pick and Place

The LUXEON emitter is packaged and shipped in tape-and-reel which is compatible with standard automated pick-and-place equipment to ensure the best placement accuracy. Note that pick and place nozzles are customer specific and are typically machined to fit specific pick and place tools. Lumileds advises customer to take the following general pick and place guidelines into account:

- a. The nozzle tip should be clean and free of any particles since they may interact with the top surface of the silicone encapsulation of the LUXEON emitter package.
- b. During setup and the first initial production runs, it is a good practice to inspect the top surface of the LUXEON emitters under a microscope to ensure that the emitters are not accidentally damaged by the pick and place nozzle.



## 5.5 Electrostatic Discharge Protection

The LUXEON emitter does not include any transient voltage suppressor (TVS) chip to protect against electrostatic discharges (ESD). Therefore, Lumileds recommends observing the following precautions when handling the LUXEON emitter:

During manual handling always use a conductive wrist band or ankle straps when positioned on a grounded conductive mat.

All equipment, machinery, work tables, and storage racks that may get in contact with the LUXEON emitter should be properly grounded.

Use an ion blower to neutralize the static discharge that may build up on the surface and lens of the plastic housing of the LUXEON emitter during storage and handling.

LUXEON emitters which are damaged by ESD may not light up at low currents and/or may exhibit abnormal performance characteristics such as a high reverse leakage current, and a low forward voltage (leaky diode). It is also important to take note that ESD can also cause latent failure, i.e. failure or symptoms as described above may not show up immediately but until after use. Hence continuous ESD protection is needed during assembly.

## 5.6 JEDEC Moisture Sensitivity

LUXEON 3030 MSL (JEDEC moisture sensitivity level) is rated as level 3. Proper storage, handling and/or baking must be adhered to prevent damage to the LUXEON emitter during reflow.

Table 2. Moisture sensitivity levels.

MSL LEVEL	FLOOR LIFE		SOAK REQUIREMENTS STANDARD	
	TIME	CONDITIONS	TIME	CONDITIONS
3	168 Hours	≤30°C / 60% RH (Relative Humidity)	192 +5 / -0 Hours	30°C / 60% RH

Table 3. Storage and baking conditions. Note that if any of the temperature, relative humidity, humidity indicator card or the period is not met, baking is required. For more information, see IPC/JEDEC J-STD-033D.

OPERATION	PACKING BAG STATUS	TEMPERATURE	RELATIVE HUMIDITY (RH)	HUMIDITY INDICATOR CARD	PERIOD
Storage	As received	≤30°C (non-condensing atmospheric environment)	≤90%	n/a	Within 1 year of shipment date
	After opening bag	≤30°C	≤60%	If 10% color spot is no longer blue	168 Hours
Baking Process (Drying)		60°C ±5°C			4 hours baking
	For bare LED packages not in the reel	OR Refer to IPC/JEDEC J-STD-033D, Table 4.1 and product datasheet for max storage temperature	≤5%	n/a	OR Refer to IPC/JEDEC J-STD-033D, Table 4.1
	For LED packages still in the reel	60°C ±5°C	≤5%	n/a	4 hours baking

## 6. Packaging Considerations—Chemical Compatibility

The LUXEON emitter package contains a silicone overcoat to protect the LED chip and extract the maximum amount of light. As with most silicones used in LED optics, care must be taken to prevent any incompatible chemicals from directly or indirectly reacting with the silicone.

The silicone overcoat used in the LUXEON emitter is gas permeable. Consequently, oxygen and volatile organic compound (VOC) gas molecules can diffuse into the silicone overcoat. VOCs may originate from adhesives, solder fluxes, conformal coating materials, potting materials and even some of the inks that are used to print the PCBs.

Some VOCs and chemicals react with silicone and produce discoloration and surface damage. Other VOCs do not chemically react with the silicone material directly but diffuse into the silicone and oxidize during the presence of heat or light. Regardless of the physical mechanism, both cases may affect the total LED light output. Since silicone permeability increases with temperature, more VOCs may diffuse into and/or evaporate out from the silicone.

Careful consideration must be given to whether LUXEON emitters are enclosed in an “air tight” environment or not. In an “air tight” environment, some VOCs that were introduced during assembly may permeate and remain in the silicone. Under heat and “blue” light, VOCs captured inside the silicone may partially oxidize and create a silicone discoloration, particularly on the surface of the LED where the flux energy is the highest. In an air rich or “open” air environment, VOCs have a chance to leave the area (driven by the normal air flow). Transferring the devices which were discolored in the enclosed environment back to “open” air may allow the oxidized VOCs to diffuse out of the silicone and may restore the original optical properties of the LED.

Determining suitable threshold limits for the presence of VOCs is very difficult since these limits depend on the type of enclosure used to house the LEDs and the operating temperatures. Also, some VOCs can photo-degrade over time.

Table 4 provides a list of commonly used chemicals that should be avoided as they may react with the silicone material. Note that Lumileds does not warrant that this list is exhaustive since it is impossible to determine all chemicals that may affect LED performance.

The chemicals in Table 4 are typically not directly used in the final products that are built around LUXEON emitters. However, some of these chemicals may be used in intermediate manufacturing steps (e.g. cleaning agents).

Consequently, trace amounts of these chemicals may remain on (sub) components, such as heat sinks. Lumileds, therefore, recommends the following precautions when designing your application:

- When designing secondary lenses to be used over an LED, provide a sufficiently large air-pocket and allow for “ventilation” of this air away from the immediate vicinity of the LED.
- Use mechanical means of attaching lenses and circuit boards as much as possible. When using adhesives, potting compounds and coatings, carefully analyze its material composition and do thorough testing of the entire fixture under High Temperature over Life (HTOL) conditions.

**Table 4. List of commonly used chemicals that will damage the silicone of the LUXEON emitter. Avoid using any of these chemicals in the housing that contains the LED package.**

CHEMICAL NAME	NORMALLY USED AS
Hydrochloric Acid	Acid
Sulfuric Acid	Acid
Nitric Acid	Acid
Acetic Acid	Acid
Sodium Hydroxide	Alkali
Potassium Hydroxide	Alkali
Ammonia	Alkali
MEK (Methyl Ethyl Ketone)	Solvent
MIBK (Methyl Isobutyl Ketone)	Solvent
Toluene	Solvent
Xylene	Solvent
Benzene	Solvent
Gasoline	Solvent
Mineral Spirits	Solvent
Dichloromethane	Solvent
Tetracholorometane	Solvent
Castor Oil	Oil
Lard	Oil
Linseed Oil	Oil
Petroleum	Oil
Silicone Oil	Oil
Halogenated Hydrocarbons (containing F, Cl, Br elements)	Misc
Rosin Flux	Solder Flux <sup>[1]</sup>
Acrylic Tape	Adhesive

**Notes for Table 4:**

1. Other than the use of no-clean solder paste qualified by customer, avoid secondary solder flux, for example when manually soldering wires close to LUXEON emitter. The solder flux should not spit onto the LUXEON emitter surface or leave excessive secondary solder flux residue onto the PCB when operating LEDs in an air tight enclosure or poorly ventilated enclosure.

## About Lumileds

Companies developing automotive, mobile, IoT and illumination lighting applications need a partner who can collaborate with them to push the boundaries of light. With over 100 years of inventions and industry firsts, Lumileds is a global lighting solutions company that helps customers around the world deliver differentiated solutions to gain and maintain a competitive edge. As the inventor of Xenon technology, a pioneer in halogen lighting and the leader in high performance LEDs, Lumileds builds innovation, quality and reliability into its technology, products and every customer engagement. Together with its customers, Lumileds is making the world better, safer, more beautiful—with light.

To learn more about our lighting solutions, visit [lumileds.com](http://lumileds.com).



©2019 Lumileds Holding B.V. All rights reserved.  
LUXEON is a registered trademark of the Lumileds Holding B.V. in the United States and other countries.

[lumileds.com](http://lumileds.com)

Neither Lumileds Holding B.V. nor its affiliates shall be liable for any kind of loss of data or any other damages, direct, indirect or consequential, resulting from the use of the provided information and data. Although Lumileds Holding B.V. and/or its affiliates have attempted to provide the most accurate information and data, the materials and services information and data are provided "as is," and neither Lumileds Holding B.V. nor its affiliates warrants or guarantees the contents and correctness of the provided information and data. Lumileds Holding B.V. and its affiliates reserve the right to make changes without notice. You as user agree to this disclaimer and user agreement with the download or use of the provided materials, information and data. A listing of Lumileds product/patent coverage may be accessed at [lumileds.com/patents](http://lumileds.com/patents).