

LUXEON XR-HL2X

High performance LED modules with extreme efficacy for robust lighting designs

LUXEON XR-HL2X is a standard integrated module compatible with off-the-shelf drivers, optics, and heat sinks. These versatile building blocks feature 8, 12 or 16 LUXEON HL2X LEDs on a MCPCB substrate for thermal efficiency and mechanical robustness. This approach simplifies system integration and accelerates time-to-market.



FEATURES AND BENEFITS

Efficacy and Luminous flux of up to 194lm/W typ and 2900lm available

CCT/CRI Options:3000K, 4000K (70 CRI)

Board level color control of ≤ 5 SDCM

MCPCB for efficient heat dissipation and mechanical robustness

UL 8750, ENEC, CE, UKCA compliance

5-year limited guarantee

PRIMARY APPLICATIONS

High Bay

Low Bay

Sport Lights

Outdoor Area Lights

Roadway Lights

Table of Contents

General Product Information	2
Product Test Conditions	2
Part Number Nomenclature	2
Lumen Maintenance	2
Environmental Compliance	2
Performance Characteristics	3
Product Selection Guide	3
Electrical Characteristics	3
Board Level Color Control	3
Absolute Maximum Ratings	4
Application Information	4
Recommended Wire	4
Characteristic Curves	5
Spectral Power Distribution Characteristics	5
Light Output Characteristics	5
Efficacy Characteristics	6
Mechanical Dimensions	8
Packaging Information	11

General Product Information

Product Test Conditions

LUXEON XR-HL2X modules are tested using a 20ms monopulse (MP) at 350mA and a case temperature, T_c , of 80°C.

Part Number Nomenclature

Part numbers for LUXEON XR-HL2X follow the convention below:

L 2 H 2 – **A A B B 0 C C M D D 0 1 0**

Where:

- A A** – designates nominal ANSI CCT (30=3000K, 40=4000K)
- B B** – designates minimum CRI (70=70CRI)
- C C** – designates number of emitters (08=8 emitters, 12=12 emitters, 16=16 emitters)
- D D** – designates internal Lumileds program code.
- 1 0** – designates internal Lumileds program code.

Therefore, a LUXEON XR-HL2X 3000K 70CRI with 16 emitters, will have the following part number:

L 2 H 2 – **3 0 7 0 0 1 6 M L U 0 1 0**

Lumen Maintenance

Please contact your local Sales Representative or Lumileds Technical Solutions Manager for more information about the long-term performance of this product.

Environmental Compliance

Lumileds LLC is committed to providing environmentally friendly products to the solid-state lighting market. LUXEON XR-HL2X is compliant to the European Union directives on the restriction of hazardous substances in electronic equipment, namely the RoHS Directive 2011/65/EU and REACH Regulation (EC) 1907/2006. Lumileds LLC will not intentionally add the following restricted materials to its products: lead, mercury, cadmium, hexavalent chromium, polybrominated biphenyls (PBB) or polybrominated diphenyl ethers (PBDE).

Performance Characteristics

Product Selection Guide

Table 1. Product performance of LUXEON XR-HL2X at 350mA, $T_c=80^\circ\text{C}$.

NOMINAL CCT	MINIMUM CRI ^[1, 2]	LUMINOUS FLUX ^[1] (lm)		TYPICAL LUMINOUS EFFICACY (lm/W)	ENERGY EFFICIENCY CLASS	PART NUMBER
		MINIMUM	TYPICAL			
3000K	70	1375	1413	186	D	L2H2-3070008MLU010
4000K	70	1435	1469	194	D	L2H2-4070008MLU010
3000K	70	2062	2120	186	D	L2H2-3070012MLU010
4000K	70	2152	2203	194	D	L2H2-4070012MLU010
3000K	70	2750	2827	186	D	L2H2-3070016MLU010
4000K	70	2869	2938	194	D	L2H2-4070016MLU010

Notes for Table 1:

- Lumileds maintains a tolerance of ± 2 on CRI and $\pm 7\%$ on luminous flux measurements.
- Typical CRI is approximately 2 points higher than the minimum CRI specified, but this is not guaranteed.

Electrical Characteristics

Table 2. Electrical characteristics for LUXEON XR-HL2X at 350mA, $T_c=80^\circ\text{C}$.

PART NUMBER	FORWARD VOLTAGE ^[1] (V_f)		
	MINIMUM	TYPICAL	MAXIMUM
L2H2-xxxx008MLU010	20.5	21.7	23.3
L2H2-xxxx012MLU010	30.7	32.5	34.9
L2H2-xxxx016MLU010	41.0	43.4	46.6

Notes for Table 2:

- Lumileds maintains a tolerance of $\pm 0.1\text{V}$ on forward voltage measurements.

Board Level Color Control

Table 3. Electrical characteristics for LUXEON XR-HL2X at 350mA, $T_c=80^\circ\text{C}$.

PART NUMBER	COLOR CONTROL
L2H2-xxxxxxxMLU010	5SDCM

Absolute Maximum Ratings

Table 4. Absolute maximum ratings for LUXEON XR-HL2X.

PARAMETER	MAXIMUM PERFORMANCE
DC Forward Current ^[1, 2]	2500mA
Peak Pulsed Forward Current ^[1, 3]	2500mA
Maximum Working Voltage ^[4]	250V
LED Junction Temperature ^[1] (DC & Pulse)	125°C
ESD Sensitivity	Class 3B (>=8000V)
Operating Case Temperature at T _c point ^[1]	-40°C to 85°C
Storage Temperature	-40°C to 125°C
Reverse Voltage (V _{reverse})	LUXEON LEDs are not designed to be driven in reverse bias

Notes for Table 4:

- Proper current derating must be observed to maintain the junction temperature below the maximum allowable junction temperature.
- Residual periodic variations due to power conversion from alternating current (AC) to direct current (DC), also called "ripple", are acceptable if the following conditions are met:
 - The frequency of the ripple current is 100Hz or higher
 - The average current for each cycle does not exceed the maximum allowable DC forward current
 - The maximum amplitude of the ripple does not exceed the maximum peak pulsed forward current
- At 10% duty cycle with pulse width of 10ms.
- Basic insulation between live parts on the LED module and mounting surface or touchable parts when mounted in a luminaire for SELV and other than SELV operation according to IEC 62031.

Application Information

Table 5. Approbation for LUXEON XR-HL2X.

ITEM	COMPLIANT TO
Test and Certification	CE
	UKCA
	ENEC
	UL8750 (UL file no. E335118)
Declaration	RoHS
	REACH

Recommended Wire

Table 6. Recommended Wire for LUXEON XR-HL2X.^[1]

RECOMMENDED WIRE	STRIP LENGTH
AWG 24-18	7mm to 9mm

Characteristic Curves

Spectral Power Distribution Characteristics

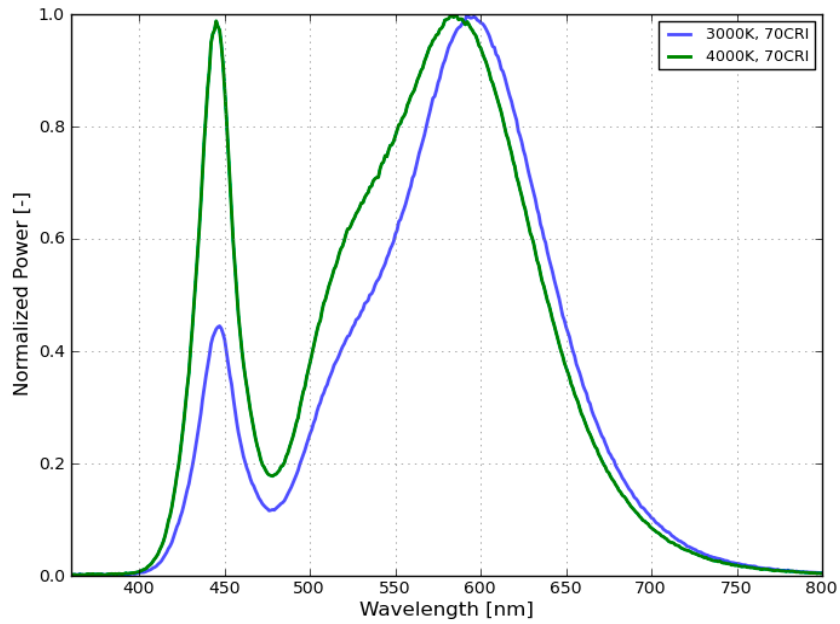

Figure 1. Typical normalized power vs. wavelength for 70CRI LUXEON XR-HL2X at 350mA, $T_c=80^\circ\text{C}$.

Light Output Characteristics

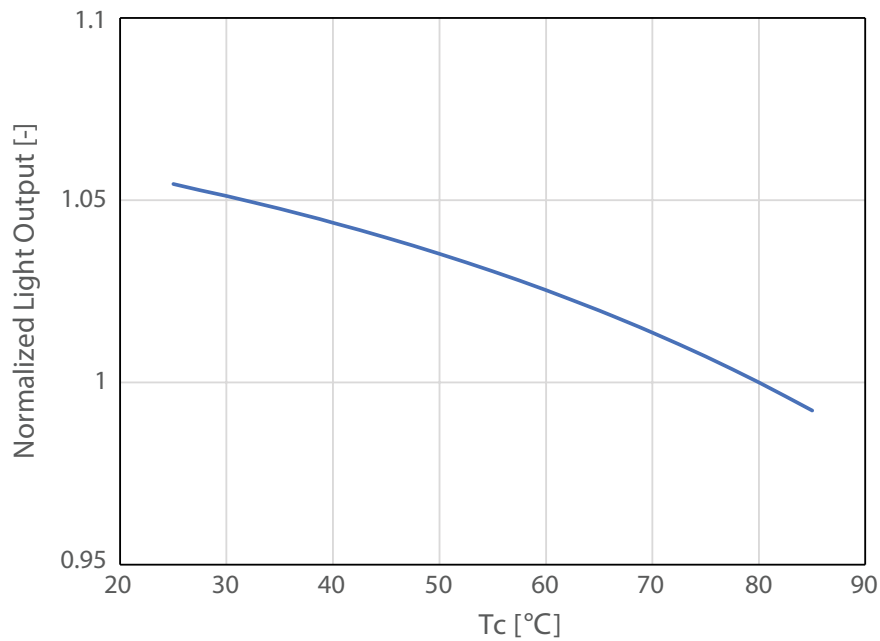

Figure 2. Typical normalized light output vs. T_c temperature for LUXEON XR-HL2X at 350mA.

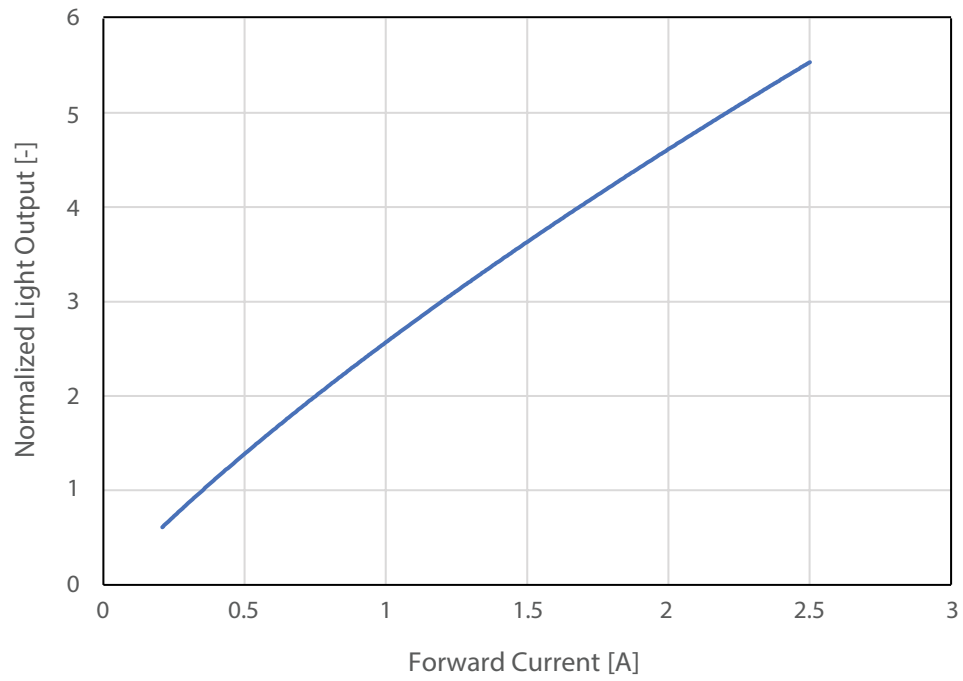

Figure 3. Typical normalized light output vs. forward current for LUXEON XR-HL2X at $T_c=80^\circ\text{C}$.

Efficacy Characteristics

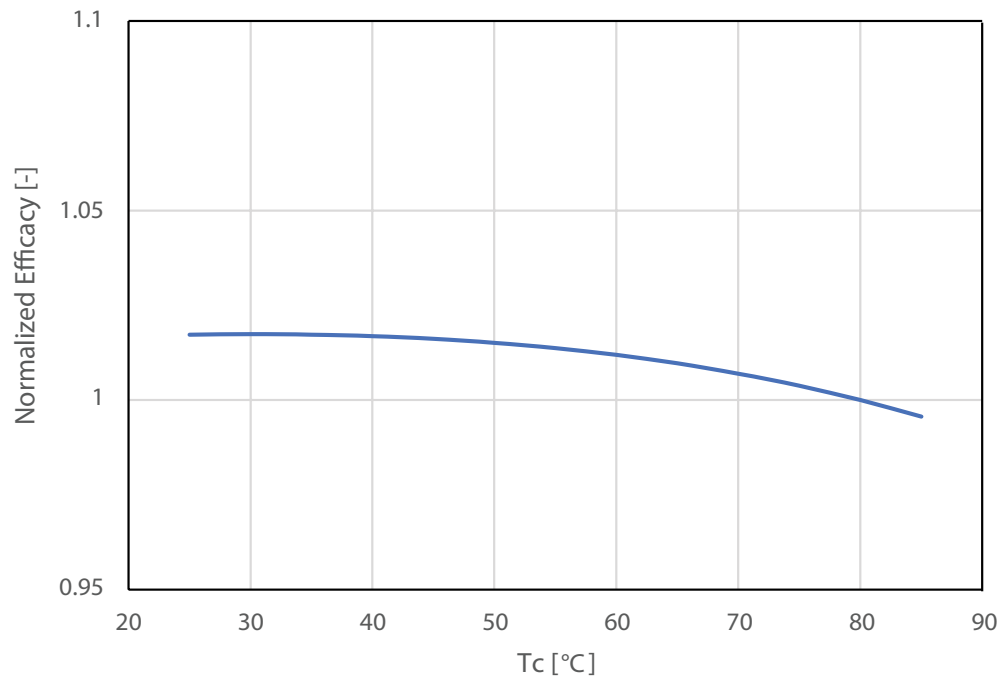

Figure 4. Typical normalized efficacy vs. T_c temperature for LUXEON XR-HL2X at 350mA.

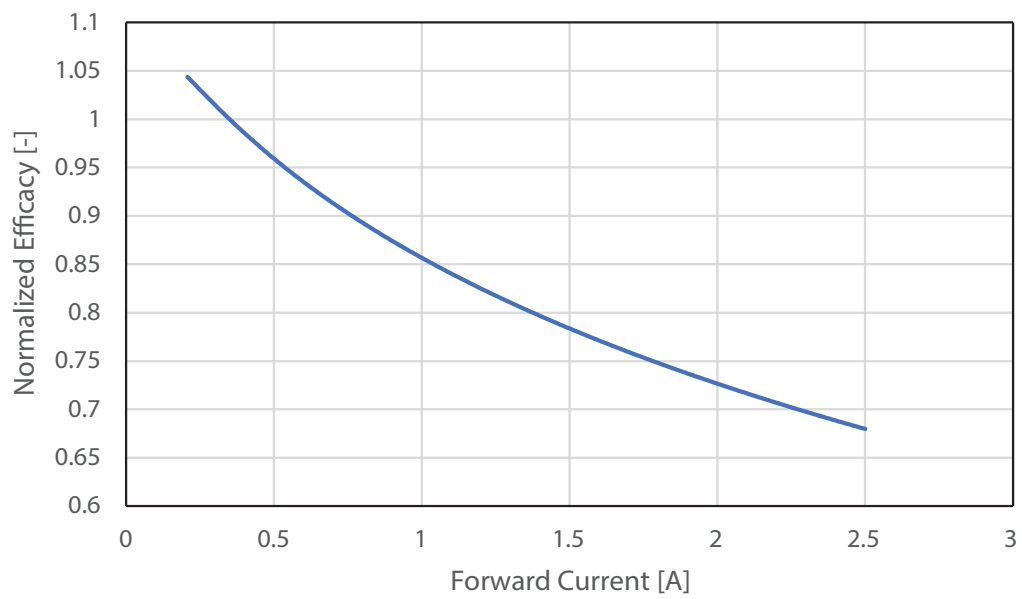

Figure 5. Typical normalized efficacy vs. forward current for LUXEON XR-HL2X at $T_c=80^{\circ}\text{C}$.

Mechanical Dimensions

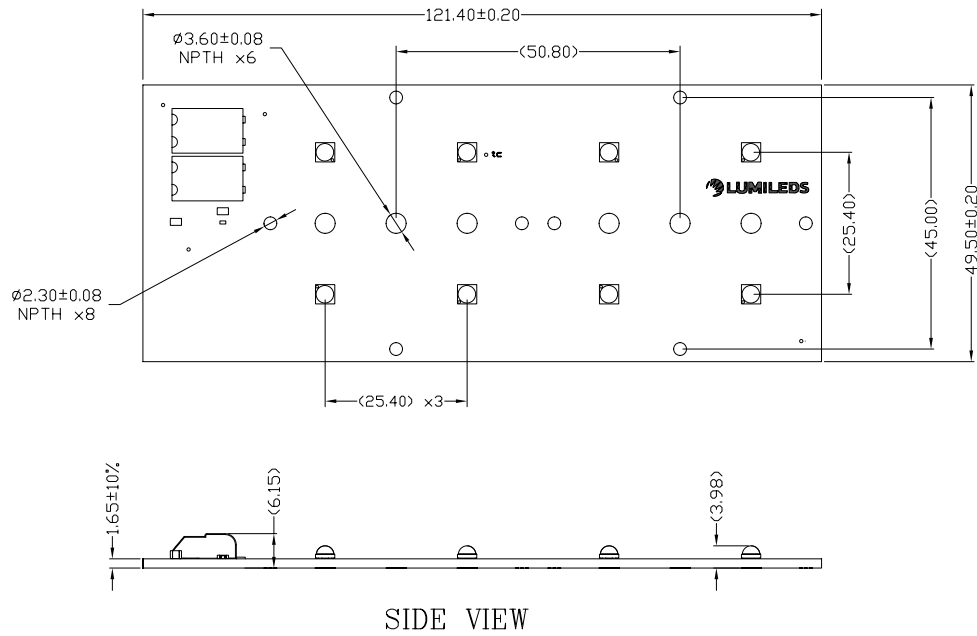

Figure 6. Mechanical dimensions for L2H2-xxxx008MLU010.

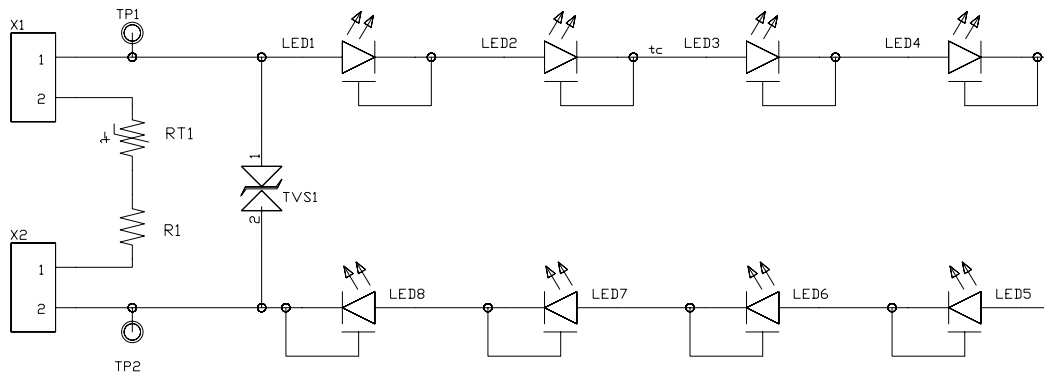

Figure 7. Electric circuit diagram for L2H2-xxxx008MLU010.

Notes for Figures 6 & 7:

1. Drawings are not to scale.
2. All dimensions are in millimeters.
3. In this document, tc is equivalent to Tc (tc or Tc is typically used in current IEC/EN or UL standards).

Table 7. Bill of Materials for L2H2-xxxx008MLU010.

COMPONENT	QUANTITY
LED: LUXEON HL2X	8
PCB: MCPCB	1
2-pole Connectors	2
Diode	1
Resistor 2k Ω	1
Thermistor 15k Ω	1

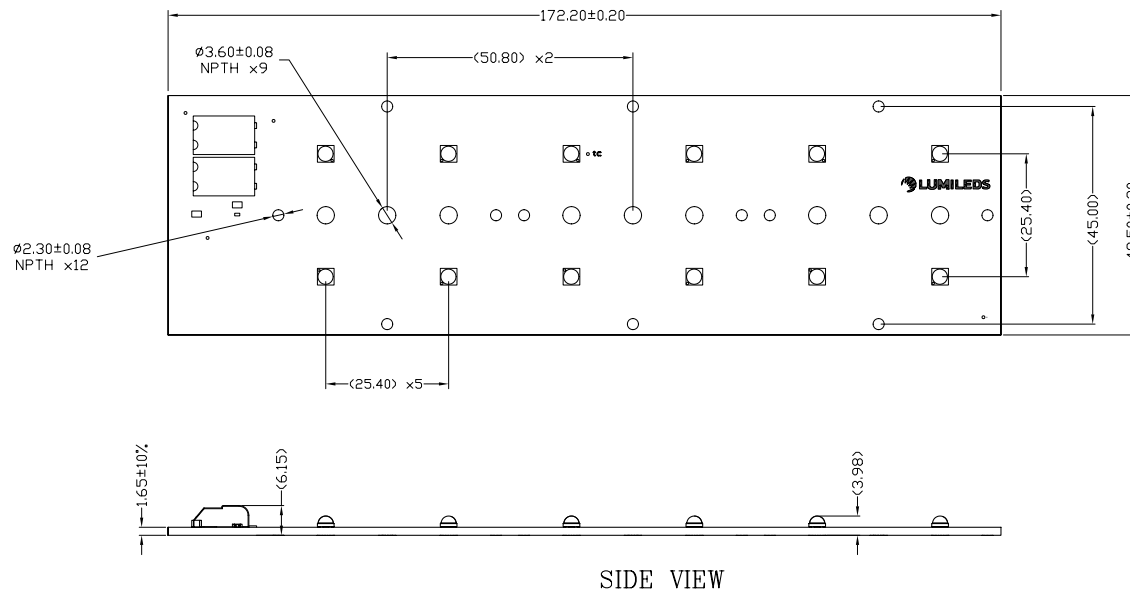

Figure 8. Mechanical dimensions for L2H2-xxxx012MLU010.

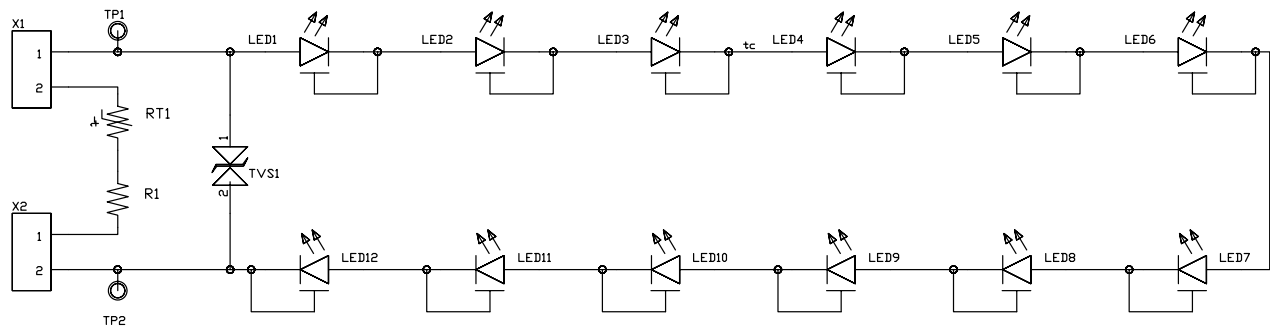

Figure 9. Electric circuit diagram for L2H2-xxxx012MLU010.

Notes for Figures 8 & 9:

1. Drawings are not to scale.
2. All dimensions are in millimeters.
3. In this document, tc is equivalent to Tc (tc or Tc is typically used in current IEC/EN or UL standards).

Table 8. Bill of Materials for L2H2-xxxx012MLU010.

COMPONENT	QUANTITY
LED: LUXEON HL2X	12
PCB: MCPCB	1
2-pole Connectors	2
Diode	1
Resistor 2kΩ	1
Thermistor 15kΩ	1

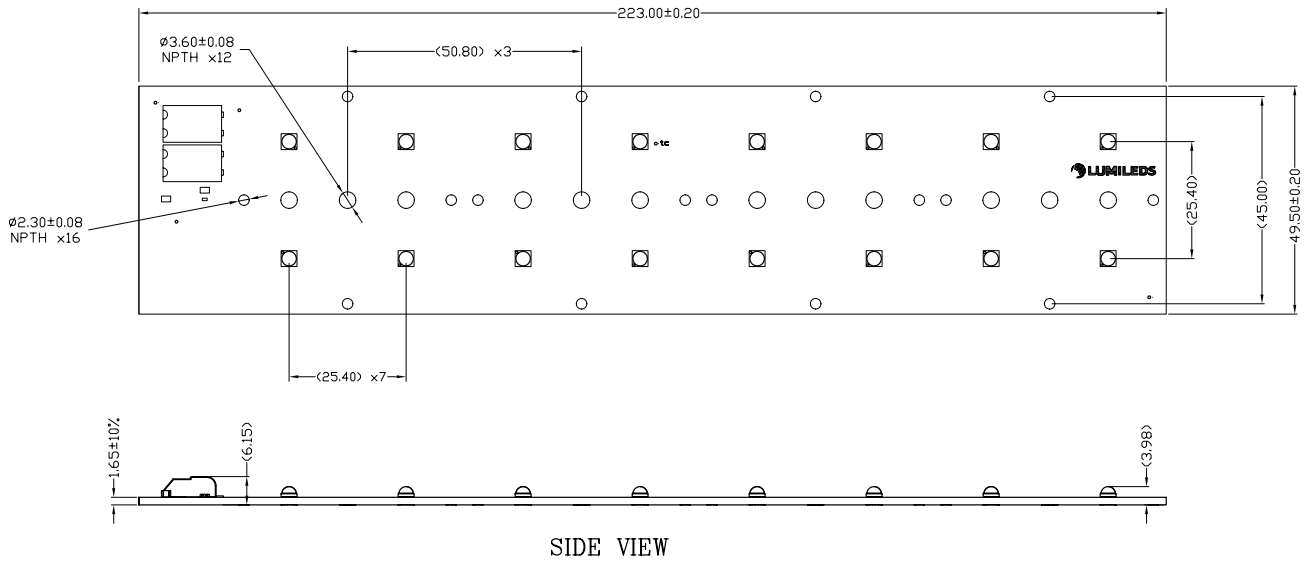

Figure 10. Mechanical dimensions for L2H2-xxxx016MLU010.

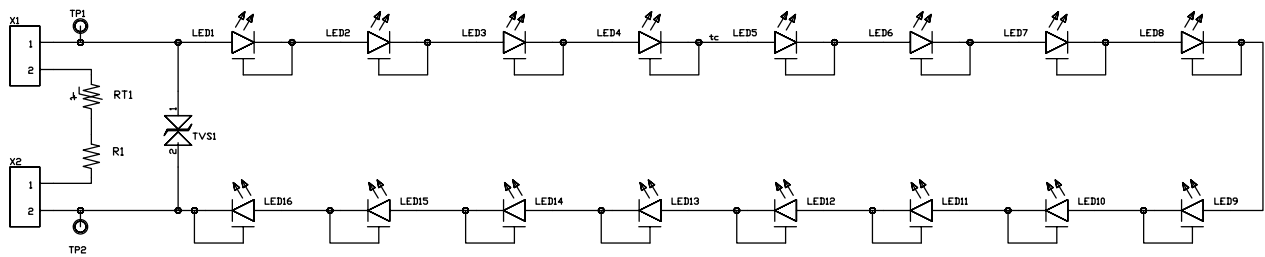

Figure 11. Electric circuit diagram for L2H2-xxxx016MLU010.

Notes for Figures 10 & 11:

1. Drawings are not to scale.
2. All dimensions are in millimeters.
3. In this document, tc is equivalent to Tc (tc or Tc is typically used in current IEC/EN or UL standards).

Table 9. Bill of Materials for L2H2-xxxx016MLU010.

COMPONENT	QUANTITY
LED: LUXEON HL2X	16
PCB: MCPCB	1
2-pole Connectors	2
Diode	1
Resistor 2kΩ	1
Thermistor 15kΩ	1

Packaging Information

Table 10. Packing information for XR-HL2X.

PART NUMBER	QUANTITY PER TRAY	TRAY QUANTITY PER BOX	STANDARD PACKING INCREMENT, SPI	SHIPPING BOX DIMENSION, L x W x H (mm)
L2H2-xxxx008MLU010	20	5	80	390 x 382 x 100
L2H2-xxxx012MLU010	20	5	80	390 x 382 x 100
L2H2-xxxx016MLU010	20	5	80	587 x 387 x 100

About Lumileds

Companies developing automotive, mobile, IoT and illumination lighting applications need a partner who can collaborate with them to push the boundaries of light. With over 100 years of inventions and industry firsts, Lumileds is a global lighting solutions company that helps customers around the world deliver differentiated solutions to gain and maintain a competitive edge. As the inventor of Xenon technology, a pioneer in halogen lighting and the leader in high performance LEDs, Lumileds builds innovation, quality and reliability into its technology, products and every customer engagement. Together with its customers, Lumileds is making the world better, safer, more beautiful—with light.

To learn more about our lighting solutions, visit lumileds.com.



©2023 Lumileds Holding B.V. All rights reserved.
LUXEON is a registered trademark of the Lumileds Holding B.V. in the United States and other countries.

lumileds.com

Neither Lumileds Holding B.V. nor its affiliates shall be liable for any kind of loss of data or any other damages, direct, indirect or consequential, resulting from the use of the provided information and data. Although Lumileds Holding B.V. and/or its affiliates have attempted to provide the most accurate information and data, the materials and services information and data are provided “as is,” and neither Lumileds Holding B.V. nor its affiliates warrants or guarantees the contents and correctness of the provided information and data. Lumileds Holding B.V. and its affiliates reserve the right to make changes without notice. You as user agree to this disclaimer and user agreement with the download or use of the provided materials, information and data. A listing of Lumileds product/patent coverage may be accessed at lumileds.com/patents.