

LUXEON FX2-L Plus Cool White

Automotive Forward Lighting Source

LUXEON FX2-L Plus Cool White LEDs are designed to support low and high beam, daytime running lamps and front fog applications. The Lumileds automotive binning structure meets both SAE and ECE color specifications and is hot binned at 85°C, consistent with actual automotive operational environments. All LUXEON FX2-L Plus LEDs are AEC-Q102 qualified.

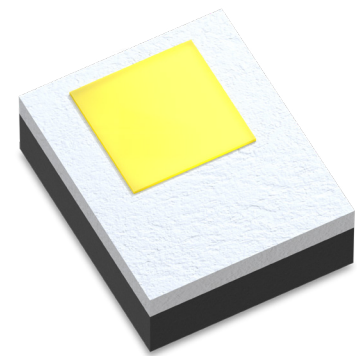
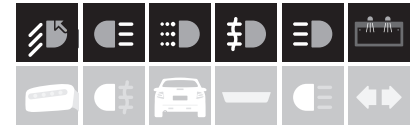

FEATURES AND BENEFITS

High drive current capability for increased flux performance

Compact, robust design with thermal solder pad enables best thermal performance on a wide variety of PCB types

Advanced CSP technology provides leading performance in a cost effective package

Hot binned at 85°C MP to match closer to operating conditions

IEC/PAS 62707-1 White LED

PRIMARY APPLICATIONS

Daytime Running Lights

Low and High Beam

ADB (Adaptive Driving Beam)

AFS (Advanced Front Lighting Systems)

Cornering Lights

Fog Lights

License plate and Back up Lights

Reverse

Table of Contents

General Product Information	2
Product Test and Binning Conditions	2
Part Number Nomenclature	2
Environmental Compliance	2
Performance Characteristics	3
Product Selection Guide	3
Optical Characteristics	3
Electrical and Thermal Characteristics	3
Absolute Ratings	4
Characteristic Curves	5
Spectral Power Distribution Characteristics	5
Light Output Characteristics	5
Forward Current and Forward Voltage Characteristics	6
Color Shift Characteristics	8
Radiation Pattern Characteristics	9
Operating Limits Characteristics	10
Permissible Pulse Handling Characteristics	11
Product Bin and Labeling Definitions	12
Decoding Product Bin Labeling	12
Luminous Flux Bins	12
Color Codes	13
Color Bin Definitions	14
Forward Voltage Bins	16
Mechanical Dimensions	17
Package Weight	17
JEDEC Moisture Sensitivity	17
Packaging Information	18
Pocket Tape Dimensions	18
Reel Dimensions	18
Product Labeling	19

General Product Information

LUXEON FX2-L Plus Cool White emitters are high-power Lumiramic© Phosphor converted InGaN emitters mounted on an AlN package. All LUXEON FX2-L Plus Cool-White emitters contain a TVS chip for ESD protection

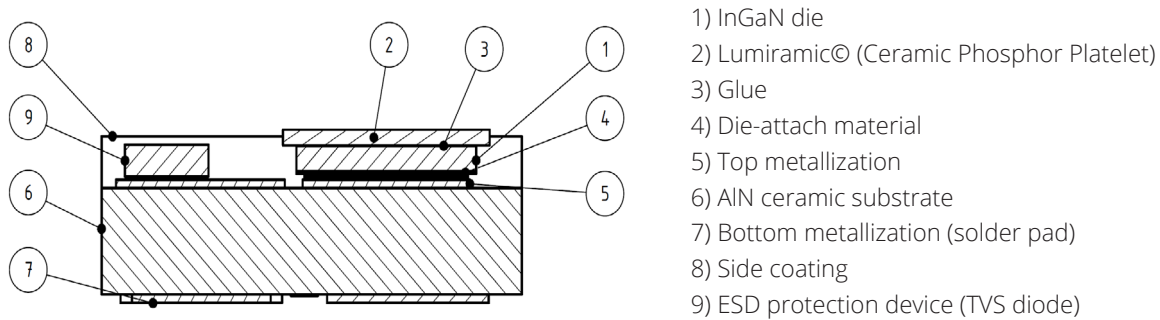

Figure 1. Schematic cross section LUXEON FX2-L Plus Cool-White

Product Test and Binning Conditions

Monopulse (MP) testing for LUXEON FX2-L Plus Cool-White is done with a pulse of 1 ms. The binning conditions for LUXEON FX2-L Plus Cool-White are MP testing at 1000 mA at a temperature of 85 °C.

Part Number Nomenclature

Part numbers for LUXEON FX2-L Plus Cool White follow the convention below:

A 1 F 2 – **B B B B** C D E **F G G G G H**

Where:

- B B B B** – designates color temperature or wavelength (5850 for cool white)
- C** – designates Lumiramic size (F = 1150 um)
- D** – designates form factor (3 = 3PAD)
- E** – designates product generation
- F** – designates future product offerings (default = 0)
- G G G G** – designates minimum luminous flux (example: 0380 = 380 lumens)
- H** – designates options code for distribution (default = 0)

Therefore, the following part number is used for a LUXEON FX2-L Plus Cool White with a minimum luminous flux of 380 lumens:

A 1 F 2 – **5 8 5 0** F 3 C **0 0 3 8 0 0**

Environmental Compliance

Lumileds LLC is committed to providing environmentally friendly products to the solid-state lighting market. LUXEON FX2-L Plus Cool White is compliant to the European Union directives on the restriction of hazardous substances in electronic equipment, namely the RoHS Directive 2011/65/EU and REACH Regulation (EC) 1907/2006. Lumileds LLC will not intentionally add the following restricted materials to its products: lead, mercury, cadmium, hexavalent chromium, polybrominated biphenyls (PBB) or polybrominated diphenyl ethers (PBDE).

Performance Characteristics

Product Selection Guide

Table 1. Product performance and optical characteristics of LUXEON FX2-L Plus Cool-White at MP binning conditions

MINIMUM LUMINOUS FLUX ^[1] (lm)	PART NUMBER
360	A1F2-5850F3C003600
370	A1F2-5850F3C003700
380	A1F2-5850F3C003800
390	A1F2-5850F3C003900

Notes for Table 1:

- Lumileds maintains a tolerance of $\pm 6.5\%$ on luminous flux measurements.

Optical Characteristics

Table 2. Optical characteristics for LUXEON FX2-L Plus Cool-White at MP binning conditions and far-field optical characteristics

PART NUMBER	CORRELATED COLOR TEMPERATURE ^[1] (K)		TYPICAL TOTAL INCLUDED ANGLE ^[2] $2\theta_{0.90V}$	TYPICAL VIEWING ANGLE ^[3] $2\theta_{1/2}$
	MINIMUM	MAXIMUM		
A1F2-5850F3Cxxxxxx	5180	6680	140°	120°

Notes for Table 2:

- Total angle at which 90% of total luminous flux is captured.
- $2\theta_{1/2}$ denotes the viewing angle, with $\theta_{1/2}$ being the off-axis angle from the LED centerline where the luminous intensity is $1/2$ of the peak value..

Electrical and Thermal Characteristics

Table 3. Electrical and thermal characteristics for LUXEON FX2-L Plus Cool-White. Electrical characteristics at MP binning condition, thermal characteristics at binning current and 25°C stage temperature.

PART NUMBER	FORWARD VOLTAGE (V_f) ^[1] [V]			THERMAL RESISTANCE— JUNCTION TO CASE (K/W)			
	MIN.	TYP.	MAX.	$R\theta_{j-c,el}$ ^[2]		$R\theta_{j-c,real}$ ^[3]	
				TYPICAL	MAXIMUM	TYPICAL	MAXIMUM
A1F2-5850F3Cxxxxxx	2.90	3.11	3.35	3.3	4.0	5.6	6.7

Notes for Table 3:

- Lumileds maintains a tolerance of $\pm 0.06V$ on forward voltage measurements.
- Ratio between temperature difference (junction to case) and electrical input power (references JESD51-51, JESD51-14).
- Ratio between temperature difference (junction to case) and dissipated heat, i.e. emitted light taken into account (references JESD51-51, JESD51-14).

Absolute Ratings

Table 4. Absolute ratings for LUXEON FX2-L Plus Cool White

PARAMETER	PERFORMANCE
Minimum DC Forward Current	50 mA
Maximum DC Forward Current ^[1]	1500 mA
Maximum Peak Pulsed Forward Current ^[1]	2500 mA
Maximum Emitter Junction Temperature ^[1] (DC & Pulse)	150 °C
Maximum Emitter Junction Temperature ^[1, 2] (DC & Pulse), short term	180 °C
ESD Sensitivity ^[3]	HBM ±8kV CDM ±2kV
Operating Case Temperature ^[1]	-40 °C to 135 °C
Emitter Storage Temperature	-40 °C to 135 °C
SMD Process Classification Temperature	260 °C
Allowable Reflow Cycles	3
Reverse Voltage (Vreverse)	Not designed to be driven in reverse bias

Notes for Table 4:

1. Proper current derating must be observed to maintain junction temperature below the maximum allowable temperature.
2. Short time operations of less than 200 hours.
3. Measured using human body model (per ANSI/ANSI/ESDA/JEDEC JS-001-2010), charged device model (AEC Q101-005 rev_A).

Characteristic Curves

Spectral Power Distribution Characteristics

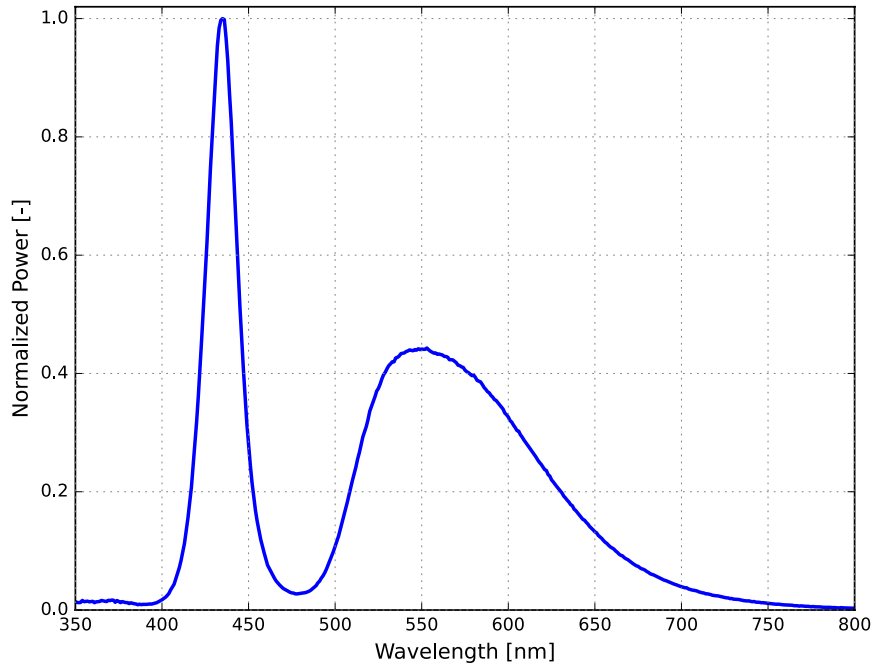

Figure 2. Typical normalized power vs. wavelength for LUXEON FX2-L Plus Cool-White at MP binning conditions

Light Output Characteristics

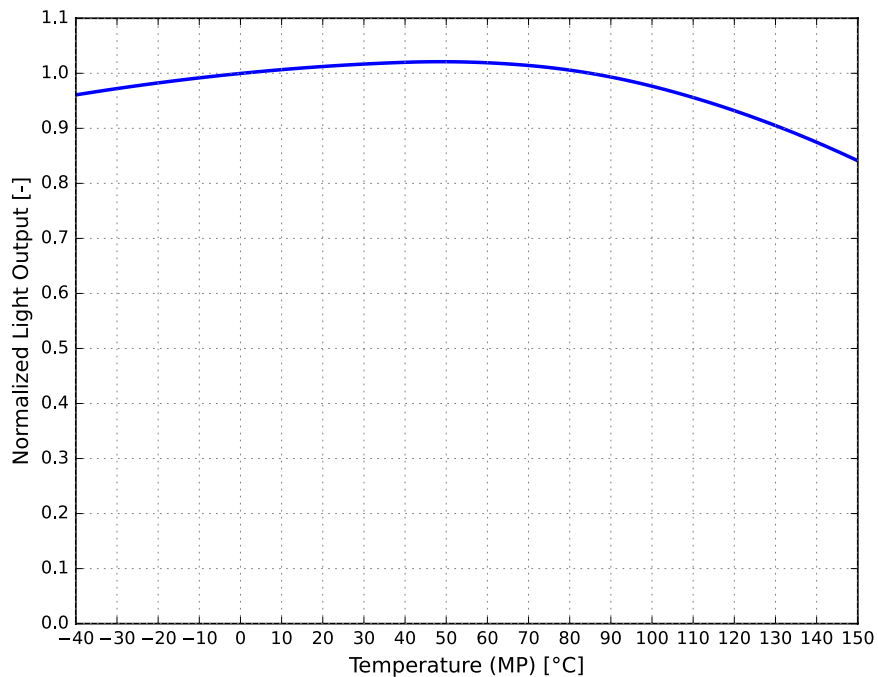

Figure 3. Typical normalized light output vs. temperature for LUXEON FX2-L Plus Cool-White at MP binning current

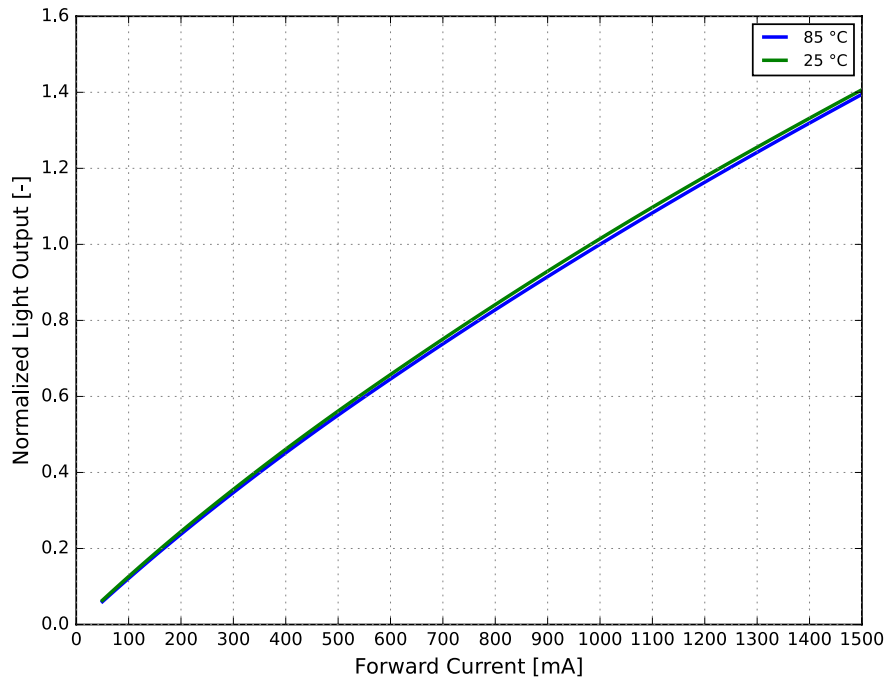

Figure 4. Typical normalized light output vs. forward current for LUXEON FX2-L Plus Cool-White at MP binning temperature and at room temperature

Forward Current and Forward Voltage Characteristics

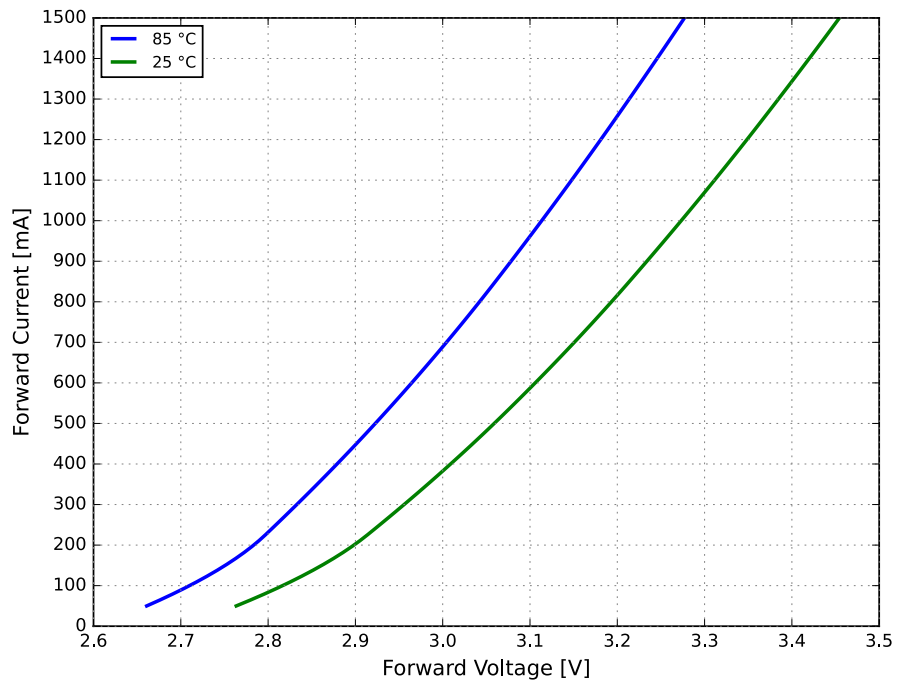

Figure 5. Typical forward current vs. forward voltage for LUXEON FX2-L Plus Cool-White at MP binning temperature and at room temperature.

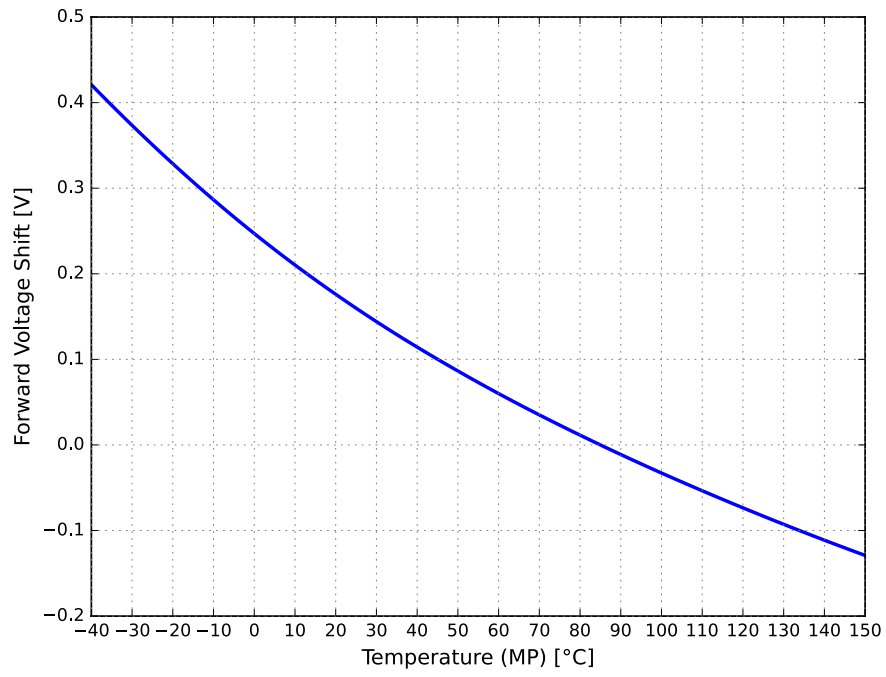

Figure 6. Typical forward voltage shift vs. temperature for LUXEON FX2-L Plus Cool-White at MP binning current

Color Shift Characteristics

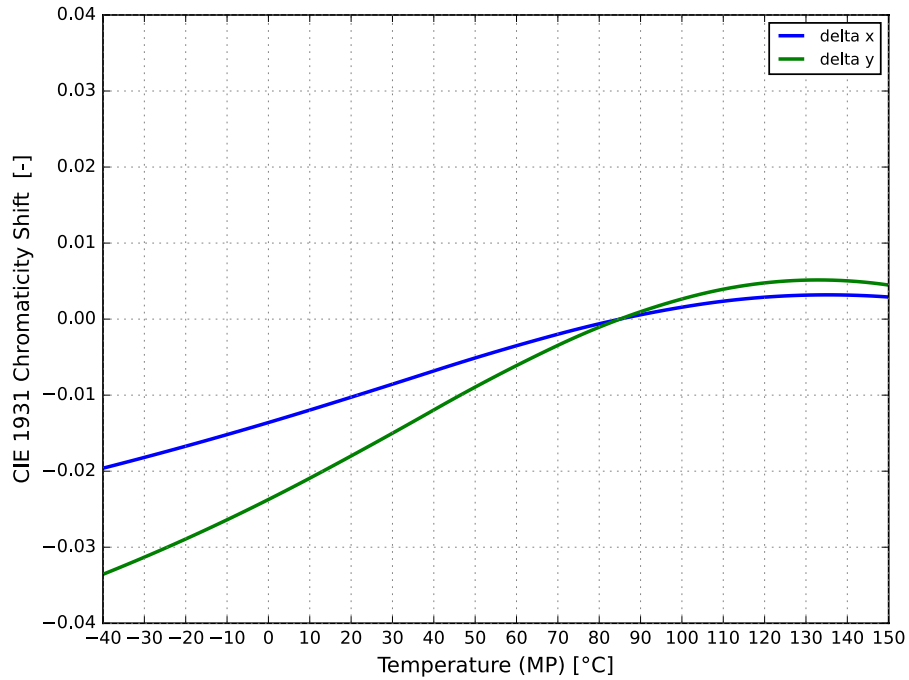

Figure 7. Typical color shift in CIE 1931 x, y coordinates vs. temperature for LUXEON FX2-L Plus Cool-White at MP binning current

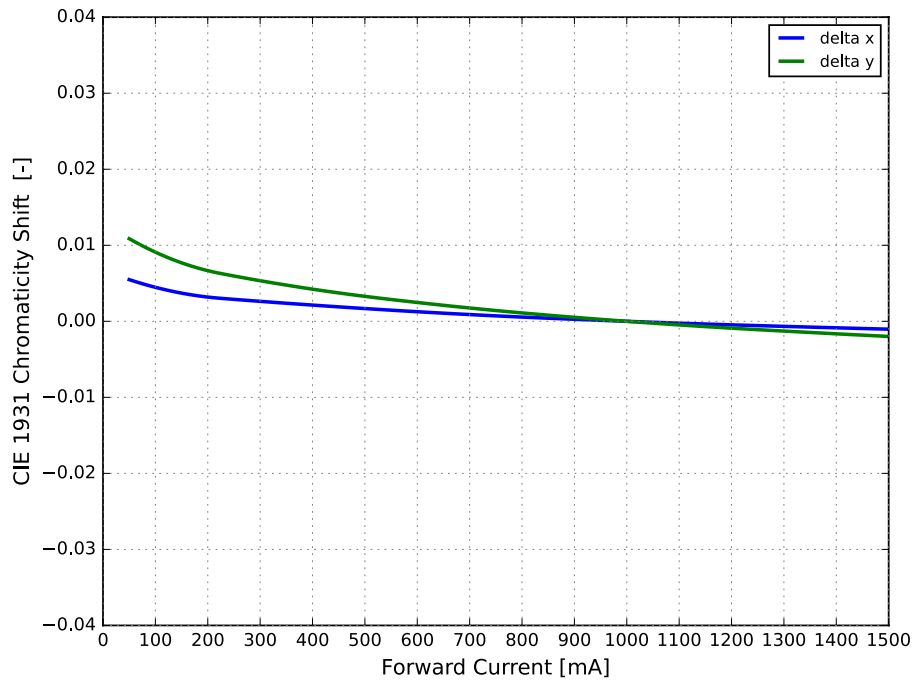

Figure 8. Typical color shift in CIE 1931 x, y coordinates vs. forward current for LUXEON FX2-L Plus Cool-White at MP binning temperature

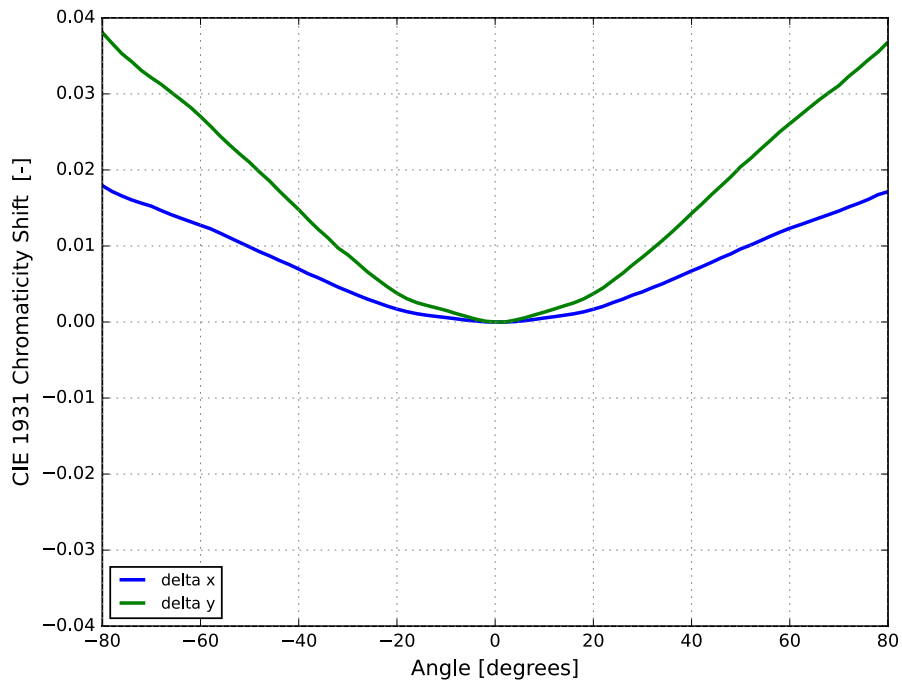

Figure 9. Typical color shift over angle for LUXEON FX2-L Plus Cool-White

Radiation Pattern Characteristics

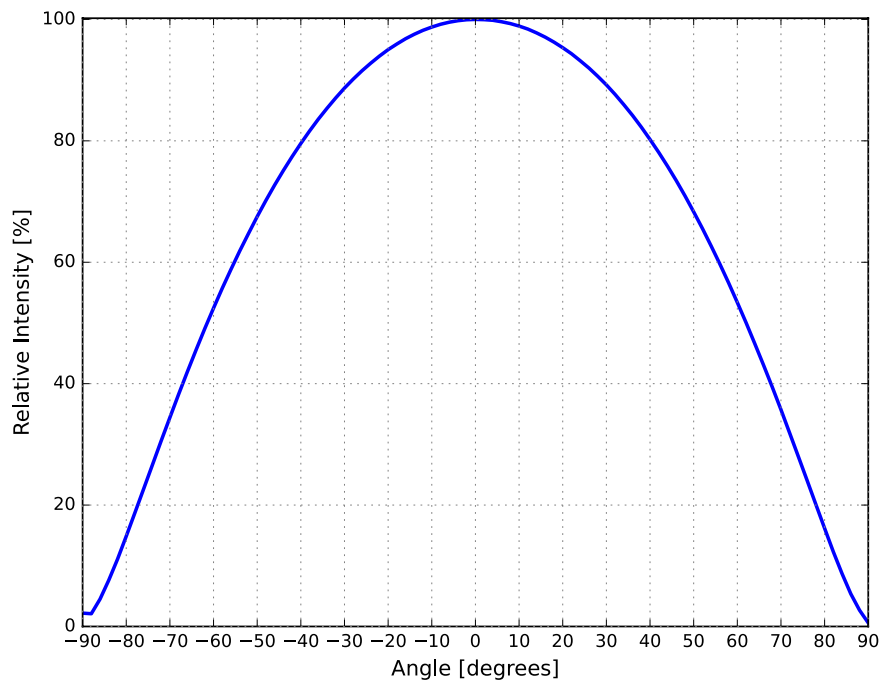

Figure 10. Typical Radiation Pattern for LUXEON FX2-L Plus Cool-White

Operating Limits Characteristics

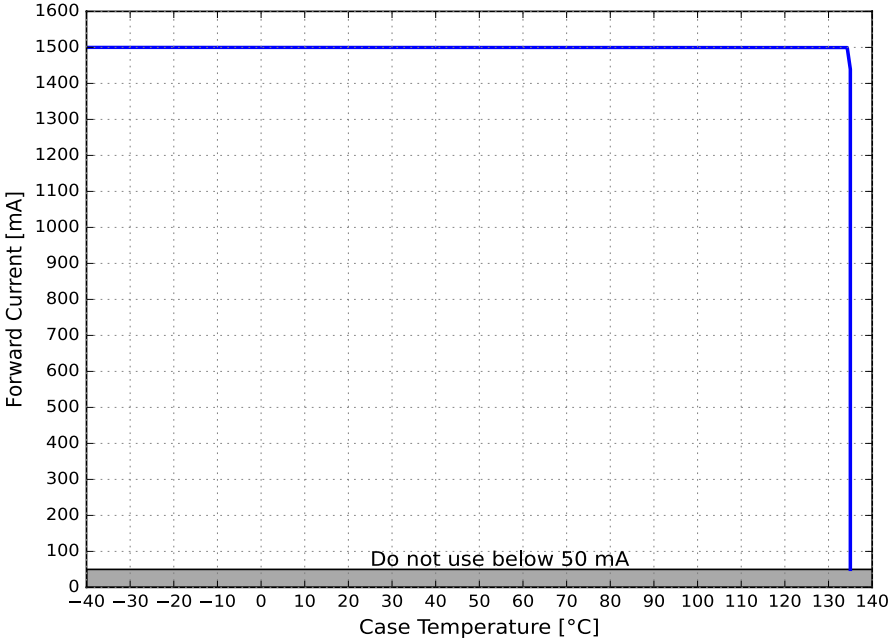

Figure 11. Maximum forward current vs. case temperature for LUXEON FX2-L Plus Cool-White

Permissible Pulse Handling Characteristics

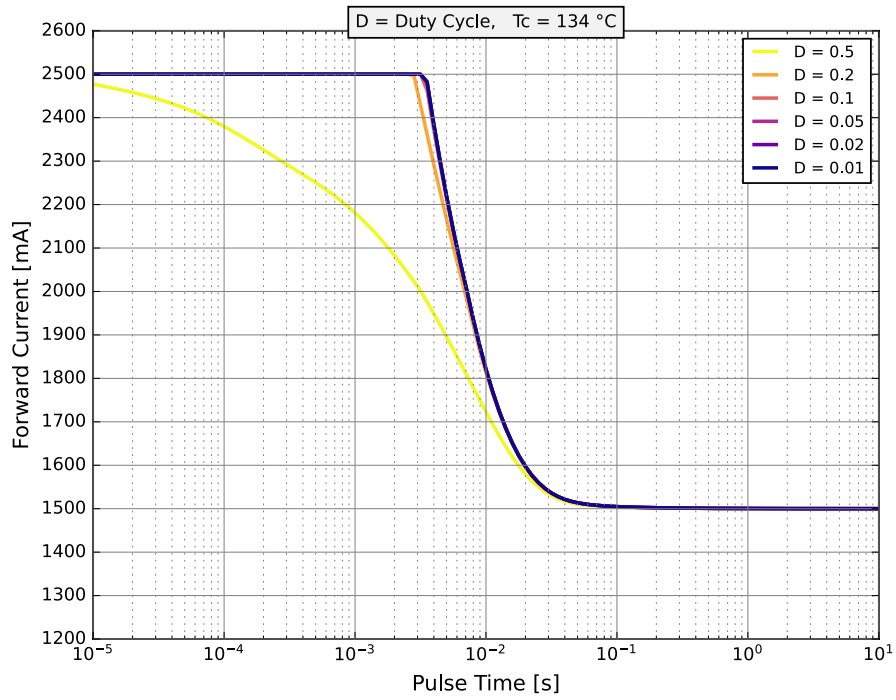

Figure 12a. Pulse handling capability for LUXEON FX2-L Plus Cool-White at highest case temperature, where maximum DC current can be applied

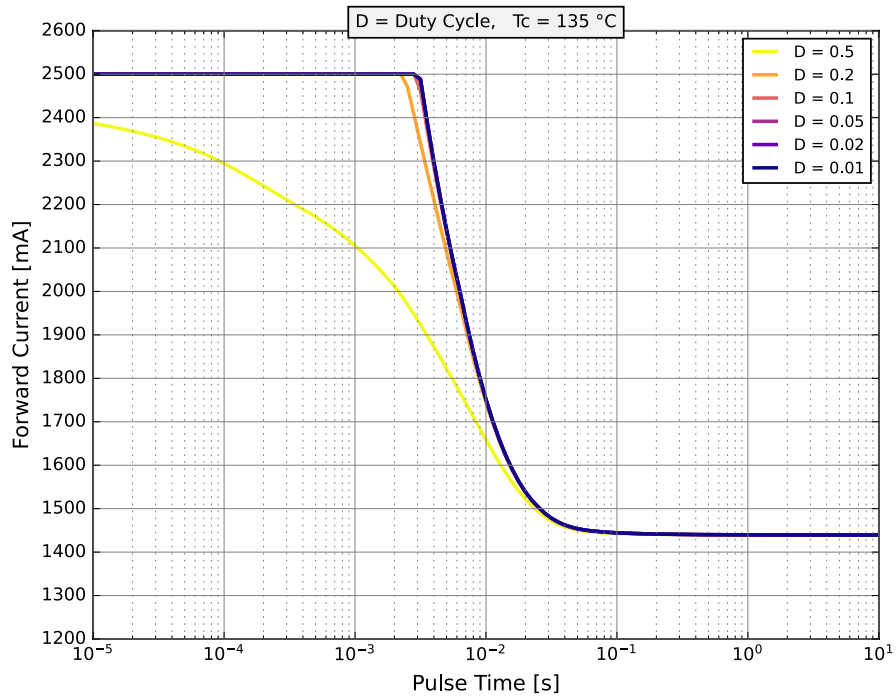

Figure 12b. Pulse handling capability for LUXEON FX2-L Plus Cool-White at maximum case temperature

Product Bin and Labeling Definitions

Decoding Product Bin Labeling

In the manufacturing of semiconductor products, there are variations in performance around the average values given in the technical datasheet. For this reason, Lumileds bins components for luminous flux or radiometric power, color point, peak or dominant wavelength and forward voltage

LUXEON FX2-L Plus Cool White LEDs are labeled using a 4-digit alphanumeric CAT code following the format below.

A B C D

Where:

- A** – designates luminous flux bin (example: Q = 370 to 380 lumens) per die
- B C** – designates color bin (example: HC)
- D** – designates forward voltage bin (example: B = 2.90 V to 3.20 V)

Therefore, a LUXEON FX2-L Plus Cool White with a lumen range of 370 to 380, color code HC and a forward voltage of 2.90 V to 3.20 V has the following CAT code:

Q H C B

Luminous Flux Bins

Table 5 lists the standard luminous flux bins for LUXEON FX2-L Plus Cool-White emitters. Although several bins are outlined, product availability in a particular bin varies by production run and by product performance

Table 5. Luminous flux bin definitions for LUXEON FX2-L Plus Cool-White at MP binning conditions

BIN	LUMINOUS FLUX ⁽¹⁾ (lm)	
	MINIMUM	MAXIMUM
N	350	360
P	360	370
Q	370	380
R	380	390
S	390	400
T	400	410
U	410	420

Notes for Table 5:

1. Lumileds maintains a tolerance of $\pm 6.5\%$ on luminous flux measurements.

Color Codes

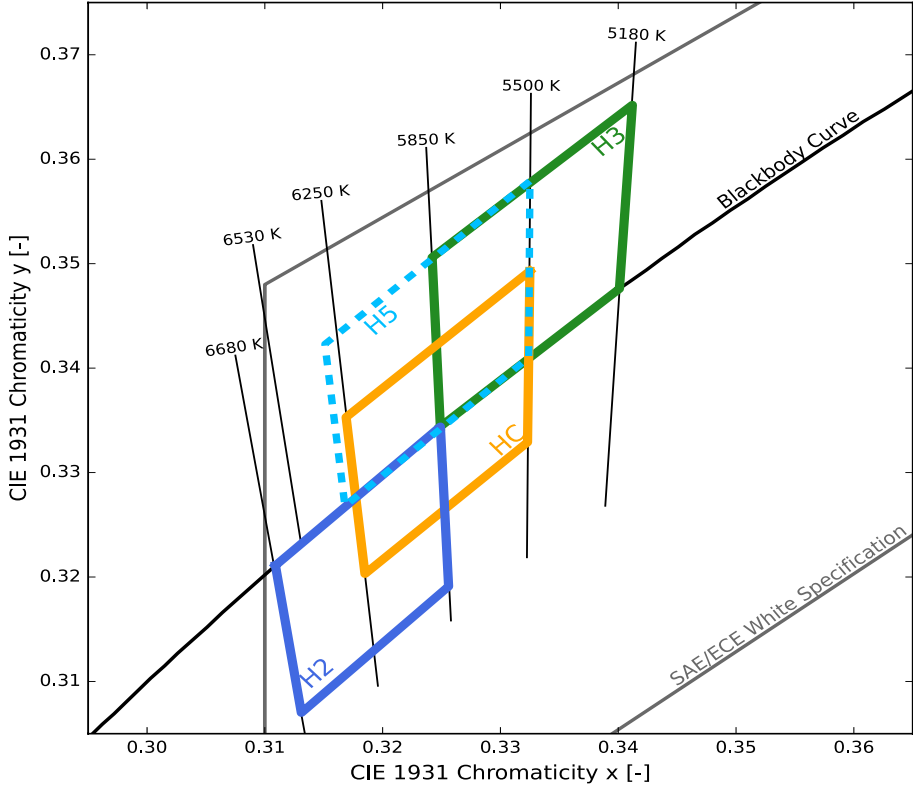

Figure 13. Color bin structure for LUXEON FX2-L Plus Cool-White

Color Bin Definitions

Table 6. Color bin definitions for LUXEON FX2-L Plus Cool-White at MP binning conditions

COLOR BIN	x ^[1, 2]	y ^[1, 2]	6-DIGIT IEC CODE	TYPICAL CCT (K)
HC	0.3325	0.3493	ebyD66	5850K
	0.3169	0.3353		
	0.3185	0.3203		
	0.3323	0.3329		
H5	0.3325	0.3579	NA	5900K
	0.3151	0.3423		
	0.3168	0.3268		
	0.3324	0.3410		
H2	0.3109	0.3211	ebvG66	6250K
	0.3131	0.3070		
	0.3256	0.3191		
	0.3249	0.3344		
H3	0.3249	0.3344	fcbA66	5500K
	0.3401	0.3476		
	0.3412	0.3652		
	0.3242	0.3506		

Notes for Table 6:

- LUXEON FX2-L Plus emitters are tested and binned by x and y coordinates.
- Lumileds maintains a tester tolerance of ±0.005 on x and y coordinates.

Table 7. Optional color bin definitions for LUXEON FX2-L Plus Cool-White at MP binning conditions

CODE	x ^[1, 2]	y ^[1, 2]	6-DIGIT IEC CODE	TYPICAL CCT (K)	CODE	x ^[1, 2]	y ^[1, 2]	6-DIGIT IEC CODE	TYPICAL CCT (K)
2B	0.3120	0.3139	ebvG33	6460K	1B	0.3120	0.3306	fbwA23	6390K
	0.3185	0.3203				0.3169	0.3353		
	0.3192	0.3131				0.3177	0.3277		
2D	0.3131	0.3070	ebyG33	6050K	1D	0.3131	0.3232	fbyA33	6050K
	0.3185	0.3203				0.3169	0.3353		
	0.3253	0.3266				0.3246	0.3424		
	0.3256	0.3191				0.3249	0.3344		
4B	0.3192	0.3131	ecbG33	5680K	3B	0.3177	0.3277	fcbA33	5680K
	0.3253	0.3266				0.3246	0.3424		
	0.3323	0.3329				0.3325	0.3493		
	0.3323	0.3251				0.3324	0.341		
4D	0.3256	0.3191	eceG33	5350K	3D	0.3249	0.3344	fceA33	5350K
	0.3323	0.3329				0.3325	0.3493		
	0.3396	0.3392				0.3406	0.3562		
	0.3392	0.3310				0.3401	0.3476		
2A	0.3323	0.3251	ebvD33	6460K	1A	0.3324	0.341	fbwD23	6390K
	0.3109	0.3211				0.3109	0.3382		
	0.3177	0.3277				0.3161	0.3432		
	0.3185	0.3203				0.3169	0.3353		
2C	0.3120	0.3139	ebyD33	6050K	1C	0.312	0.3306	fbyD33	6050K
	0.3177	0.3277				0.3161	0.3432		
	0.3249	0.3344				0.3242	0.3506		
	0.3253	0.3266				0.3246	0.3424		
4A	0.3185	0.3203	ecbD33	5680K	3A	0.3169	0.3353	fcbD33	5680K
	0.3249	0.3344				0.3242	0.3506		
	0.3324	0.3410				0.3325	0.3579		
	0.3323	0.3329				0.3325	0.3493		
4C	0.3253	0.3266	eceD33	5350K	3C	0.3246	0.3424	fceD33	5350K
	0.3324	0.3410				0.3325	0.3579		
	0.3401	0.3476				0.3412	0.3652		
	0.3396	0.3392				0.3406	0.3562		
	0.3323	0.3329				0.3325	0.3493		

Notes for Table 7:

1. Lumileds maintains a tolerance of ±0.005 on (x,y) color coordinates.
2. CIE 1931 x and y coordinate frame.

Forward Voltage Bins

Forward voltage distribution of Lumileds LEDs is very narrow, nevertheless for some applications the restriction of forward voltage is beneficial. On request individual bins are available according to table 8.

Table 8. Forward voltage bin definitions for LUXEON FX2-L Plus Cool-White at MP binning conditions

BIN	FORWARD VOLTAGE ⁽¹⁾ (V _f)	
	MINIMUM	MAXIMUM
B	2.90	3.20
C	3.20	3.35

Notes for Table 8:

1. Lumileds maintains a tolerance of $\pm 0.06V$ on forward voltage measurements.

Mechanical Dimensions

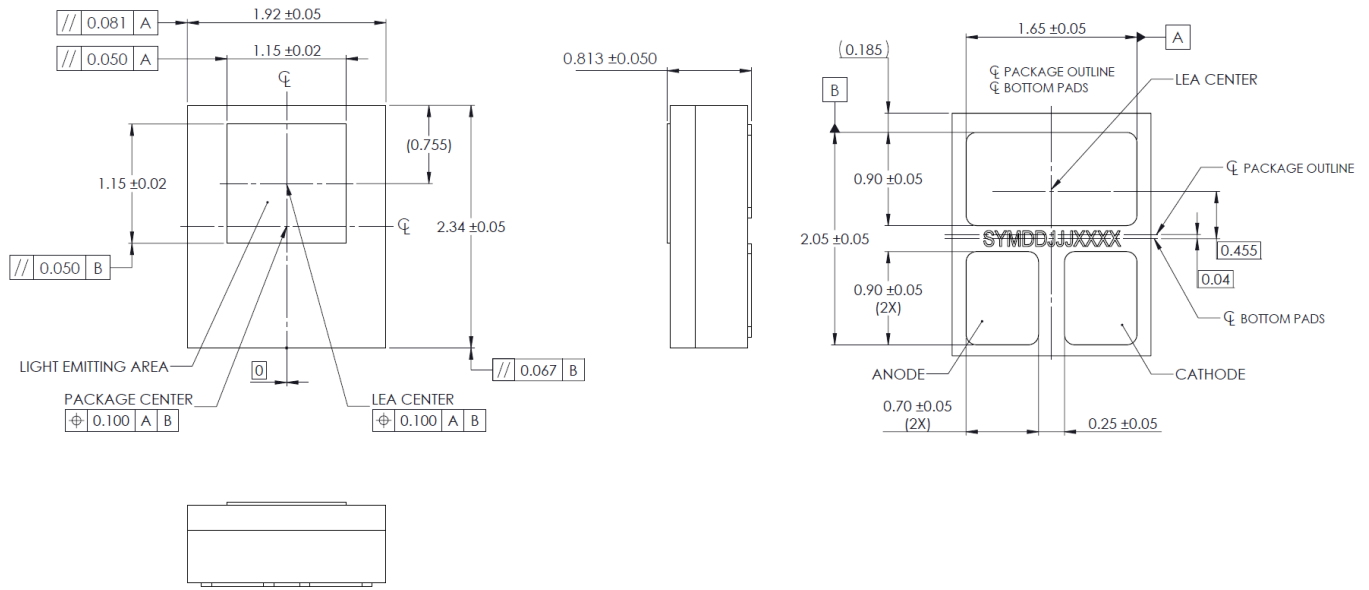

Figure 14: Mechanical Dimensions for LUXEON FX2-L Plus Cool-White

Notes for Figure 14:

1. Drawings are not to scale.
2. All dimensions are in millimeters.

Package Weight

Table 9. Approximate weight of LUXEON FX2-L Plus Cool-White

PART NUMBER	PACKAGE WEIGHT [MG]
A1F2-5850F3Cxxxxxx	12.8

JEDEC Moisture Sensitivity

Table 10. Moisture sensitivity levels for LUXEON FX2-L Plus Cool-White

LEVEL	FLOOR LIFE		STANDARD SOAK REQUIREMENTS	
	TIME	CONDITIONS	TIME	CONDITIONS
1	Unlimited	≤30 °C / 85% RH	168 Hours +5 / -0	85 °C / 85% RH

Packaging Information

Pocket Tape Dimensions

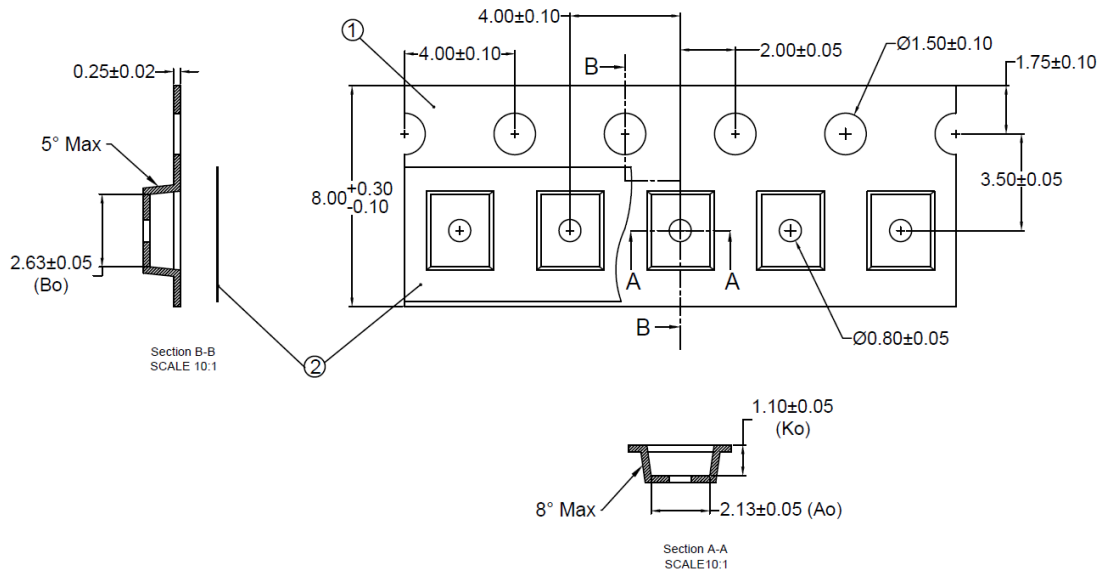

- ① Carrier Tape
- ② Cover Tape

Figure 15. Pocket tape dimensions for LUXEON FX2-L Plus Cool-White

Notes for Figure 15:

1. Drawings are not to scale.
2. Ao is the width of pocket Ko is the depth of pocket. Bo is the height of pocket
3. All dimensions are in millimeters.

Reel Dimensions

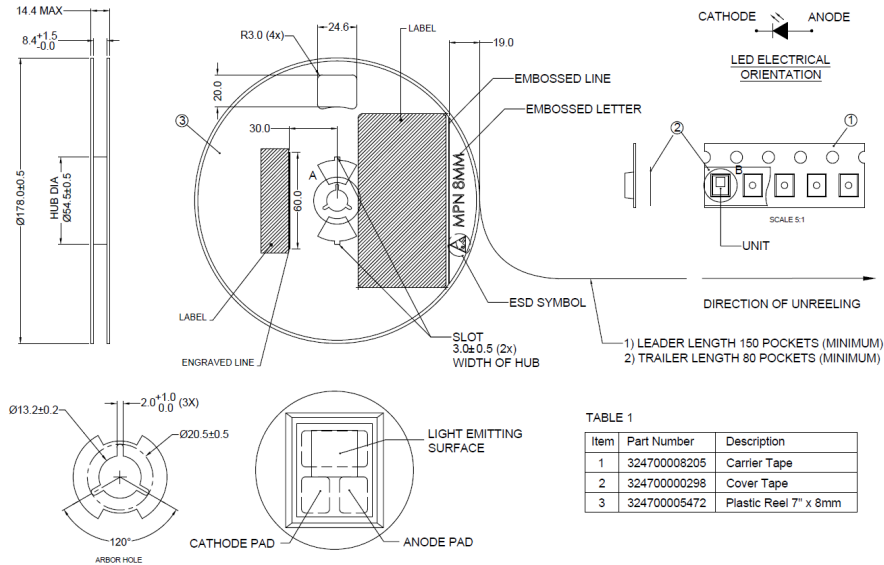

Item	Part Number	Description
1	324700008205	Carrier Tape
2	324700000298	Cover Tape
3	324700005472	Plastic Reel 7" x 8mm

Figure 16. Reel dimensions for LUXEON FX2-L Plus Cool-White

Notes for Figure 16:

1. Drawings are not to scale.
2. All dimensions are in millimeters.

Product Labeling

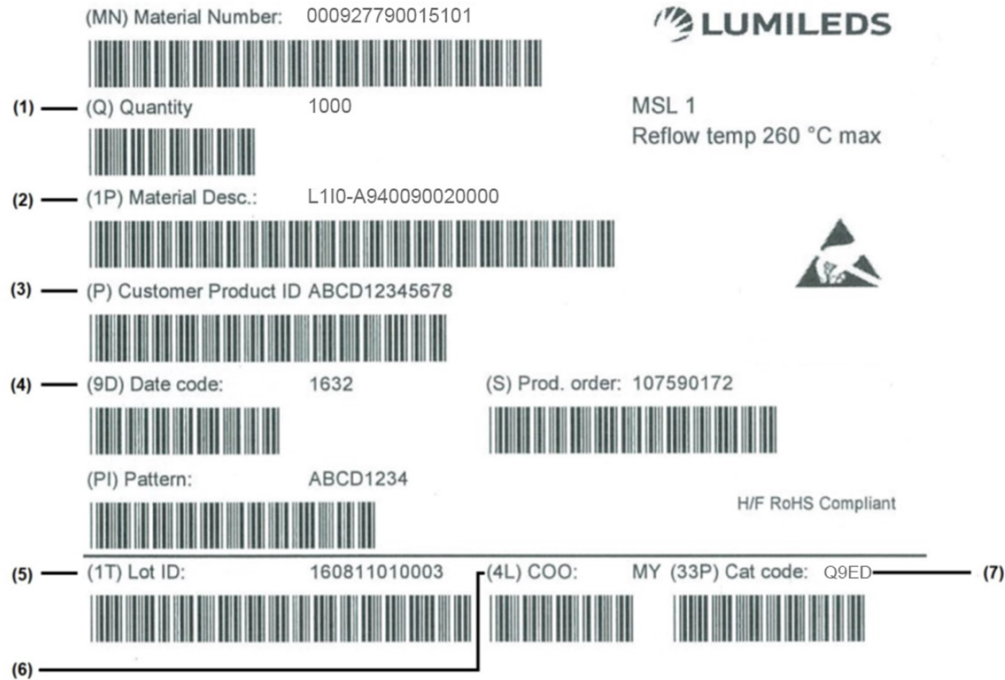

Figure 17. Example of a product label for LUXEON FX2-L Plus Cool White

Notes for Figure 17 – Box Label descriptions for customer use:

Field labels not described are for Lumileds internal use only.

1. Total number of LED emitters in a shipment box.
2. Lumileds part number
3. Customer part number for custom requests only.
4. LED test date in YYWW format.
5. Unique product lot identification number. This number is required for traceability purposes.
6. Country code of origin of manufacturing of part (e.g. MY for Malaysia, CN for China) according to ISO 3166-1 alpha-2 document.
7. Product bin 4-digit alphanumeric CAT code.

About Lumileds

Companies developing automotive, mobile, IoT and illumination lighting applications need a partner who can collaborate with them to push the boundaries of light. With over 100 years of inventions and industry firsts, Lumileds is a global lighting solutions company that helps customers around the world deliver differentiated solutions to gain and maintain a competitive edge. As the inventor of Xenon technology, a pioneer in halogen lighting and the leader in high performance LEDs, Lumileds builds innovation, quality and reliability into its technology, products and every customer engagement. Together with its customers, Lumileds is making the world better, safer, more beautiful—with light.

To learn more about our lighting solutions, visit lumileds.com.



©2023 Lumileds Holding B.V. All rights reserved.
LUXEON is a registered trademark of the Lumileds Holding B.V. in the United States and other countries.
lumileds.com

Neither Lumileds Holding B.V. nor its affiliates shall be liable for any kind of loss of data or any other damages, direct, indirect or consequential, resulting from the use of the provided information and data. Although Lumileds Holding B.V. and/or its affiliates have attempted to provide the most accurate information and data, the materials and services information and data are provided “as is,” and neither Lumileds Holding B.V. nor its affiliates warrants or guarantees the contents and correctness of the provided information and data. Lumileds Holding B.V. and its affiliates reserve the right to make changes without notice. You as user agree to this disclaimer and user agreement with the download or use of the provided materials, information and data. A listing of Lumileds product/patent coverage may be accessed at lumileds.com/patents.