

LUXEON Altilon SMD

Automotive forward lighting source

LUXEON Altilon SMD is specifically designed and tested to meet and exceed expectations for reliability, performance, and lifetime in automotive forward lighting applications. It is designed to be assembled with industry standard soldering reflow lines simplifying system integration and lowering assembly costs.

LUXEON Altilon SMD provides industry-best thermal performance in LED forward lighting applications, meeting both SAE and ECE color specifications with finer granularity than existing systems. PPAP documentation is available upon request. All LUXEON Altilon SMD LEDs are AECQ-102 qualified.

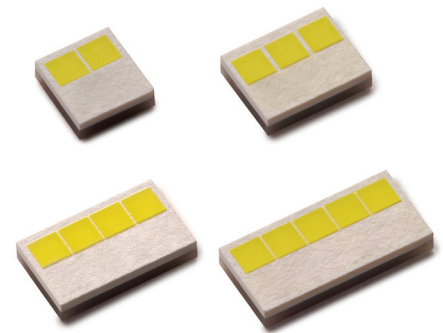
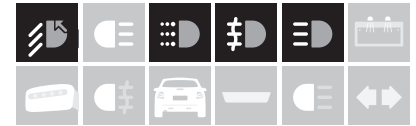

FEATURES AND BENEFITS

- Higher drive current capability for increased flux performance
- Low thermal resistance and power consumption results in simplified thermal management and system cost
- High flux output provides flexibility in styling and optical design
- Surface mount device to reduce overall costs

PRIMARY APPLICATIONS

- Adaptive Lighting
 - AFS
- Daytime Running Lights
- Front Fog
- Headlight
 - Low Beam
 - High Beam
 - Static Bending

Table of Contents

General Product Information	2
Product Test Conditions	2
Part Number Nomenclature	2
Environmental Compliance	2
Performance Characteristics	3
Product Selection Guide	3
Optical Characteristics	3
Electrical and Thermal Characteristics	4
Absolute Ratings	4
Characteristic Curves	5
Spectral Power Distribution Characteristics	5
Light Output Characteristics	5
Forward Current and Voltage Characteristics	6
Color Shift Characteristics	9
Radiation Pattern Characteristics	10
Operating Limits Characteristics	10
Product Bin and Labeling Definitions	11
Designing with LUXEON Altilon SMD	11
Decoding Product Bin Labeling	11
Luminous Flux Bins	12
Color Bin Structure	13
Color Bin Definitions	13
Mechanical Dimensions	15
Reflow Soldering Guidelines	17
JEDEC Moisture Sensitivity	17
Solder Pad Design	18
Packaging Information	18
Pocket Tape Dimensions	18
Reel Dimensions	20
Product Labeling	23

General Product Information

Product Test Conditions

LUXEON Altilon SMD LEDs are tested and binned using a 20ms monopulse (MP) at 1000mA drive current, case temperature, T_c of 85°C.

Part Number Nomenclature

Part numbers for LUXEON Altilon SMD follow the convention below:

A 1 S C – 5 8 5 0 **B** D H 0 **C C C C** 0

Where:

B – designates number of die (2, 3, 4 or 5)

C C C C – designates minimum flux bin

Therefore, the following part number is used for a LUXEON Altilon SMD with 3 die and a minimum of 780 lumens:

A 1 S C – 5 8 5 0 **3** D H 0 **0 7 8 0** 0

Environmental Compliance

Lumileds LLC is committed to providing environmentally friendly products to the solid-state lighting market. LUXEON Altilon SMD is compliant to the European Union directives on the restriction of hazardous substances in electronic equipment, namely the RoHS Directive 2011/65/EU and REACH Regulation (EC) 1907/2006. Lumileds LLC will not intentionally add the following restricted materials to its products: lead, mercury, cadmium, hexavalent chromium, polybrominated biphenyls (PBB) or polybrominated diphenyl ethers (PBDE).

Performance Characteristics

Product Selection Guide

Table 1. Product selection for LUXEON Altilon SMD at 1000mA, 20ms MP, $T_c=85^\circ\text{C}$.

CONFIGURATION	PART NUMBER
1x2	A1SC-58502DH0xxxx0
1x3	A1SC-58503DH0xxxx0
1x4	A1SC-58504DH0xxxx0
1x5	A1SC-58505DH0xxxx0

Optical Characteristics

Table 2. Typical optical characteristics for LUXEON Altilon SMD at 1000mA, $T_c=85^\circ\text{C}$.

PART NUMBER	CORRELATED COLOR TEMPERATURE		TYPICAL TOTAL INCLUDED ANGLE ^[1] $\theta_{0.90V}$	TYPICAL VIEWING ANGLE ^[2] $\theta_{1/2}$
	MINIMUM	MAXIMUM		
A1SC-58502DH0xxxx0	5500K	6250K	140°	120°
A1SC-58503DH0xxxx0	5500K	6250K	140°	120°
A1SC-58504DH0xxxx0	5500K	6250K	140°	120°
A1SC-58505DH0xxxx0	5500K	6250K	140°	120°

Notes for Table 2:

1. Total angle at which 90% of total luminous flux is captured.
2. Viewing angle is the off axis angle from the LED centerline where the luminous intensity is 1/2 of the peak value.

Electrical and Thermal Characteristics

Table 3. Typical electrical and thermal characteristics for LUXEON Altilon SMD at 1000mA, 20ms MP, $T_c=85^\circ\text{C}$.

PARAMETER		PERFORMANCE			
		1x2	1x3	1x4	1x5
Forward Voltage, V_f ^[1]	min	5.5	8.2	11.1	13.8
	max	7.0	10.3	13.6	16.9
Electrical Thermal Resistance, $R_{th-jc\text{electr}}$ ^[2]	typ	2.2°C/W	1.8°C/W	1.5°C/W	1.2°C/W
	max	2.5°C/W	2.1°C/W	1.8°C/W	1.5°C/W
Real Thermal Resistance, $R_{th-jc\text{real}}$ ^[3]	typ	3.2°C/W	2.6°C/W	2.2°C/W	1.8°C/W
	max	3.5°C/W	3.0°C/W	2.6°C/W	2.2°C/W

Notes for Table 3:

- Lumileds maintains a tolerance of $\pm 0.06\text{V}$ on forward voltage measurements.
- $R_{th-jc\text{electr}}$: Electrical thermal resistance (junction to case).
- $R_{th-jc\text{real}}$: Real thermal resistance (junction to case) with wall plug efficiency included. Reference JESD51-51, JESD51-14, 4.1.3.

Absolute Ratings

Table 4. Absolute ratings for LUXEON Altilon SMD.

PARAMETER	PERFORMANCE			
	1x2	1x3	1x4	1x5
Minimum DC Forward Current	100mA			
Maximum DC Forward Current	1500mA			
Operating Case Temperature at 700mA ^[1, 2]	-40°C to 130°C			
Maximum Junction Temperature ^[1, 2, 3]	150°C			
Operating Case Temperature at Maximum Current	-40°C to 125°C			
Maximum Junction Temperature for Short Time Applications ^[4]	175°C			
Maximum V_f at 1500mA & -40°C ^[1, 3]	7.8	11.6	15.4	19.3
Minimum V_f at 1500mA & 150°C	5.5	8.1	11.0	13.6
LED Storage Temperature	-40°C to 130°C			
Soldering Temperature	JEDEC 020c 260°C			
Allowable Reflow Cycles	2			
ESD Sensitivity ^[5]	8kV HBM, 2kV CDM, 400V MM			
Reverse Voltage (V_{reverse})	LUXEON Altilon SMD LEDs are not designed to be driven in reverse bias			

Notes for Table 4:

- Proper current derating must be observed to maintain junction temperature below the maximum, so that the LED is maintained below the maximum rated operating case temperature.
- LUXEON Altilon SMD LEDs driven at or above the maximum rated operating case temperature may have shorter lifetime.
- Please consult with Lumileds for more information on maximum time durations and forward currents for these temperatures.
- Short time operations of less than 200hrs.
- Measured using human body model (per JESD22 A114), machine model (per JESD22 A115) and charged device model (per JESD22 C101).

Characteristic Curves

Spectral Power Distribution Characteristics

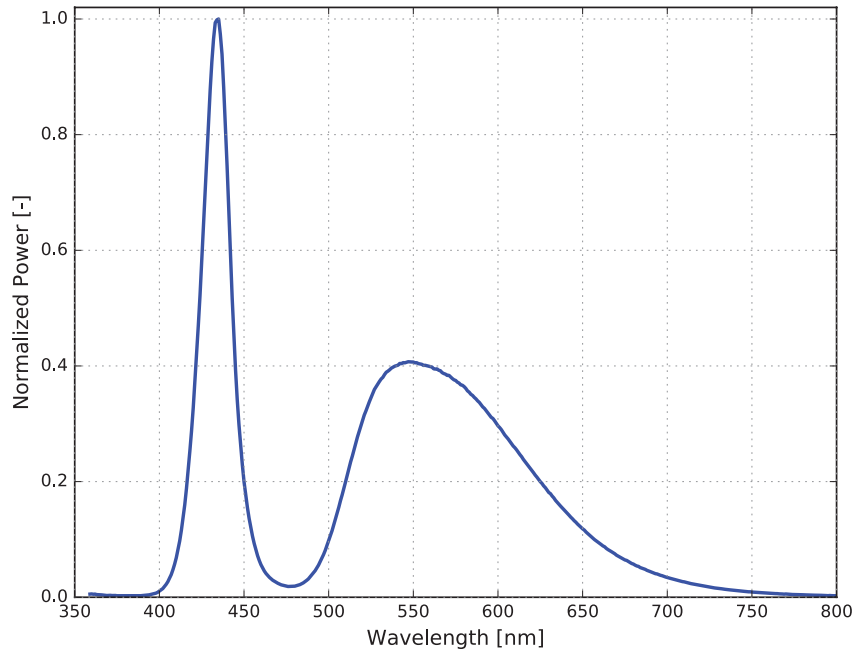

Figure 1. Typical normalized power vs. wavelength for LUXEON Altilon SMD at 1000mA, 20ms MP, $T_c=85^\circ\text{C}$.

Light Output Characteristics

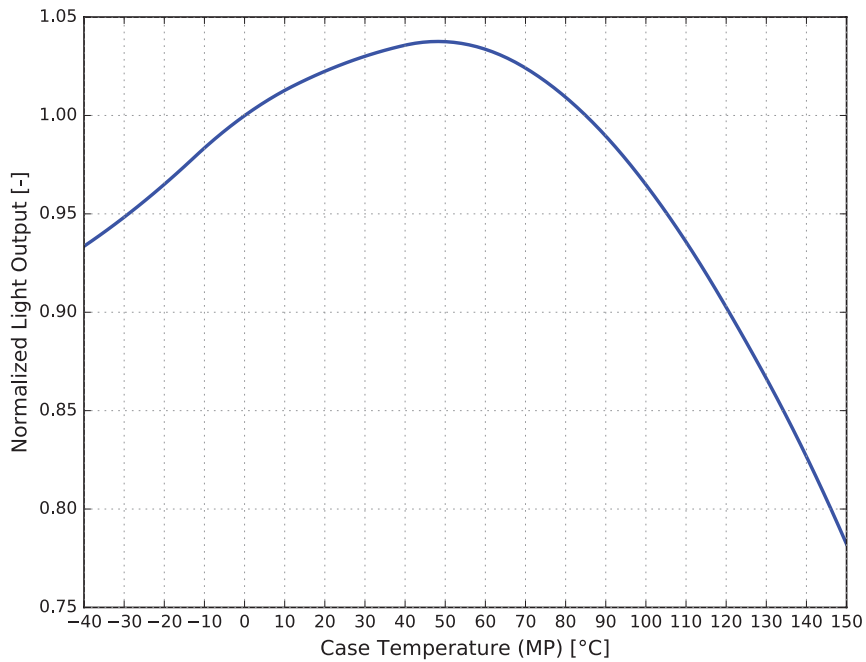

Figure 2a. Typical normalized light output vs. case temperature for LUXEON Altilon SMD at 1000mA, 20ms MP.

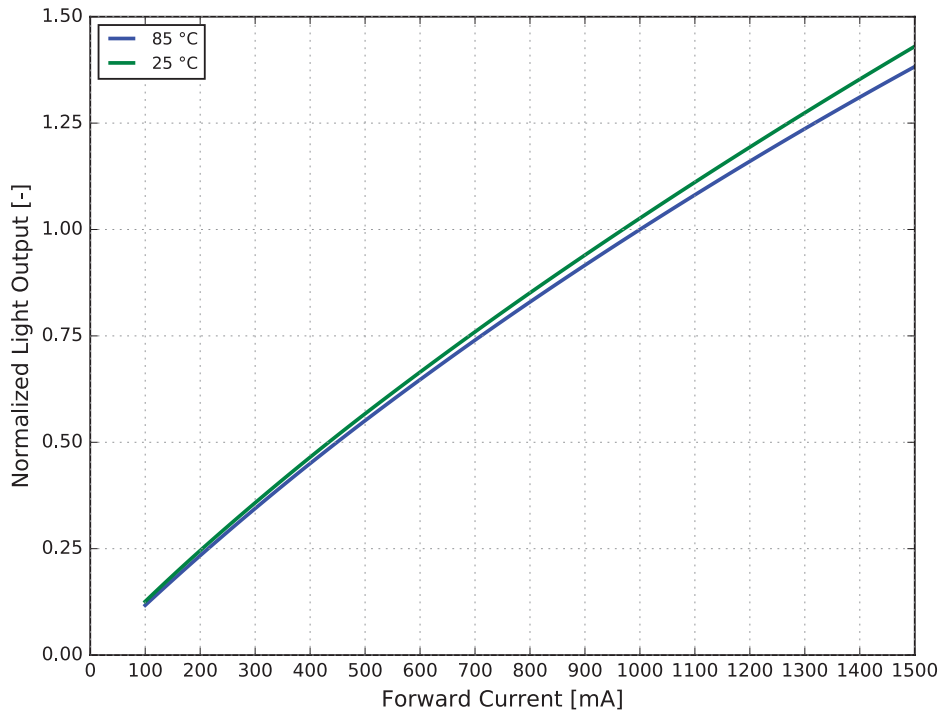

Figure 2b. Typical normalized light output vs. forward current for LUXEON Altilon SMD at $T_c=85^\circ\text{C}$.

Forward Current and Voltage Characteristics

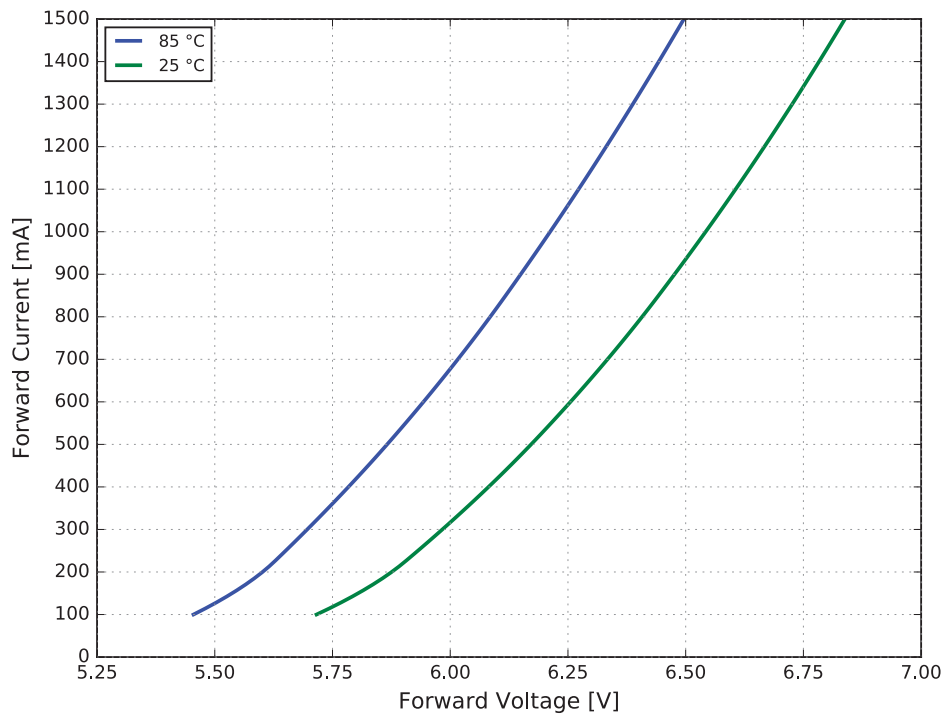

Figure 3a. Typical forward current vs. forward voltage for LUXEON Altilon SMD 1x2 at $T_c=85^\circ\text{C}$.

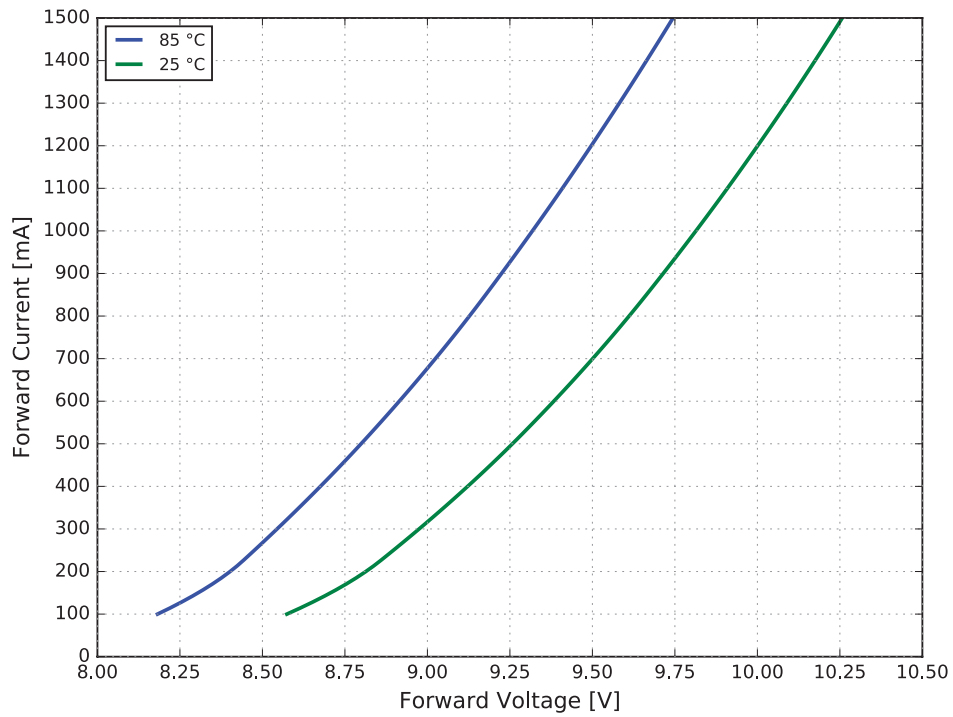

Figure 3b. Typical forward current vs. forward voltage for LUXEON Altilon SMD 1x3 at $T_c=85^\circ\text{C}$.

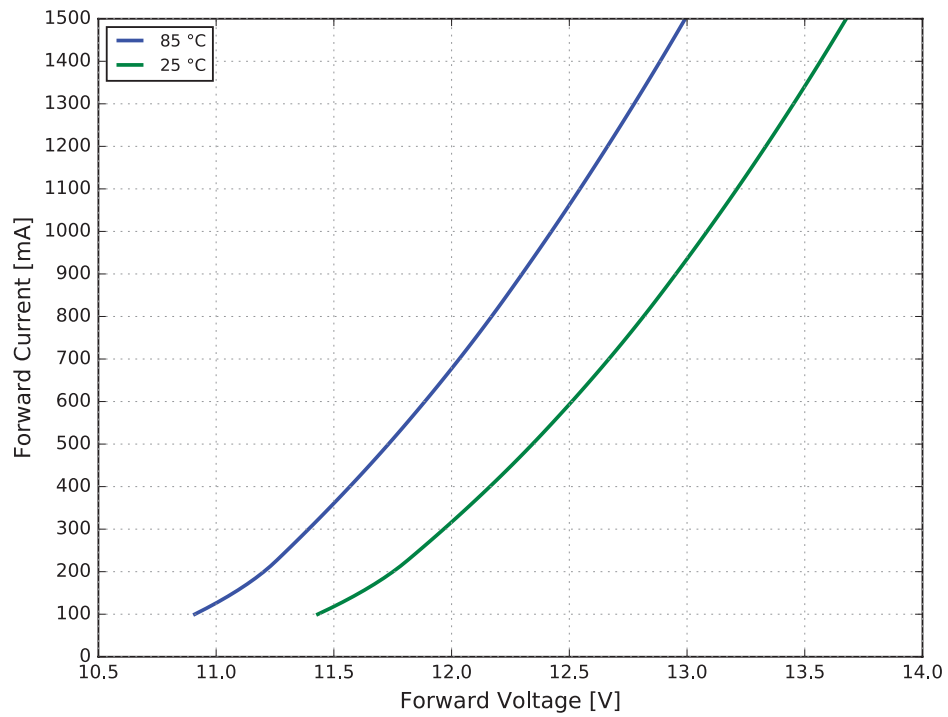

Figure 3c. Typical forward current vs. forward voltage for LUXEON Altilon SMD 1x4 at $T_c=85^\circ\text{C}$.

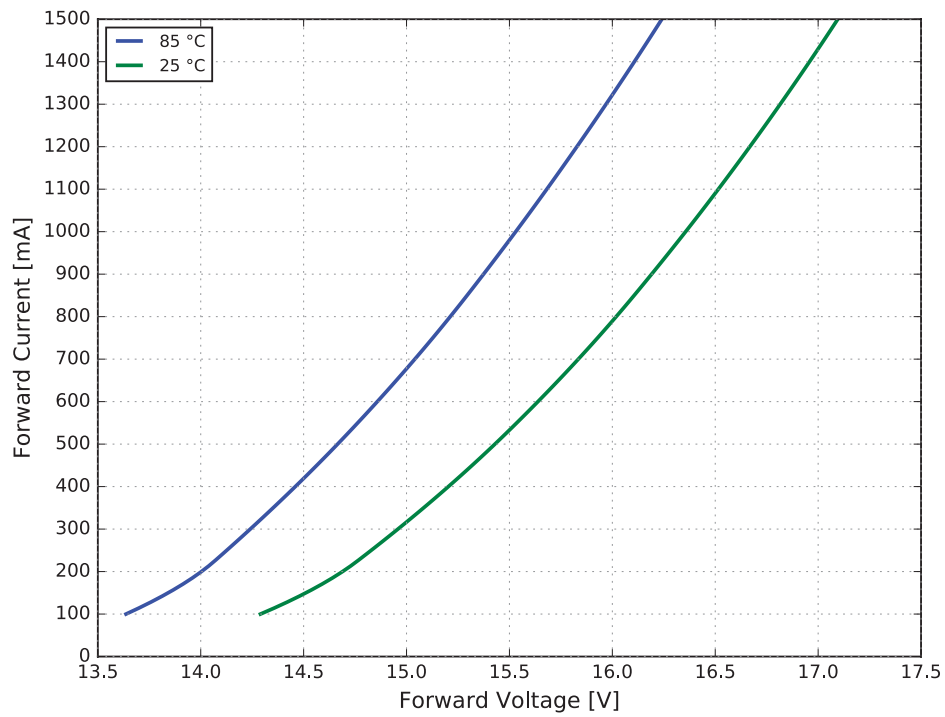

Figure 3d. Typical forward current vs. forward voltage for LUXEON Altilon SMD 1x5 at $T_c=85^\circ\text{C}$.

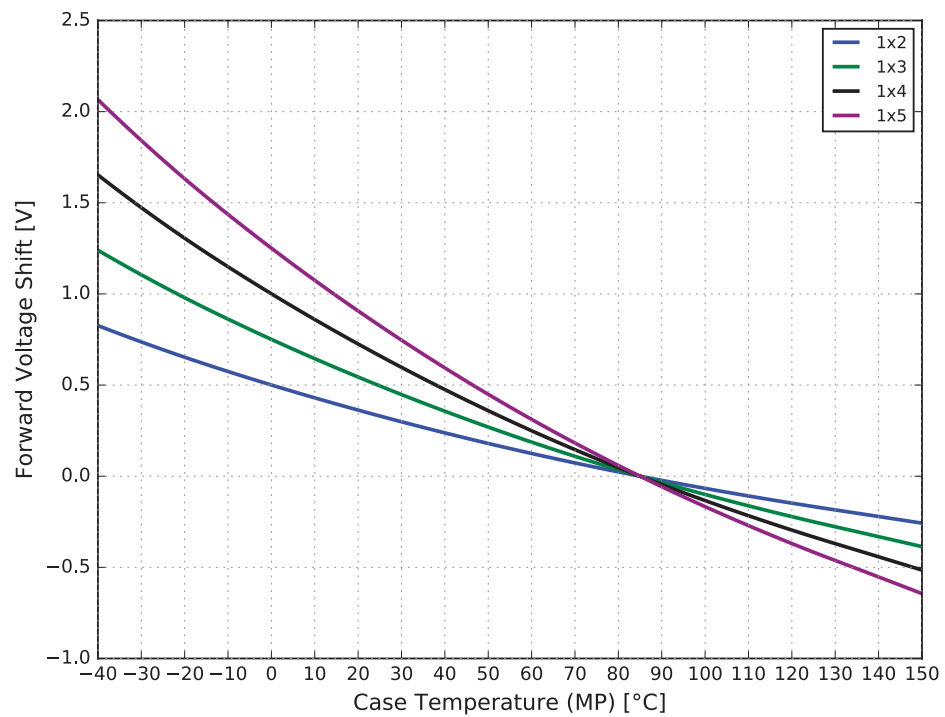

Figure 3e. Typical forward voltage shift vs. case temperature for LUXEON Altilon SMD at 1000mA, 20ms MP, $T_c=85^\circ\text{C}$.

Color Shift Characteristics

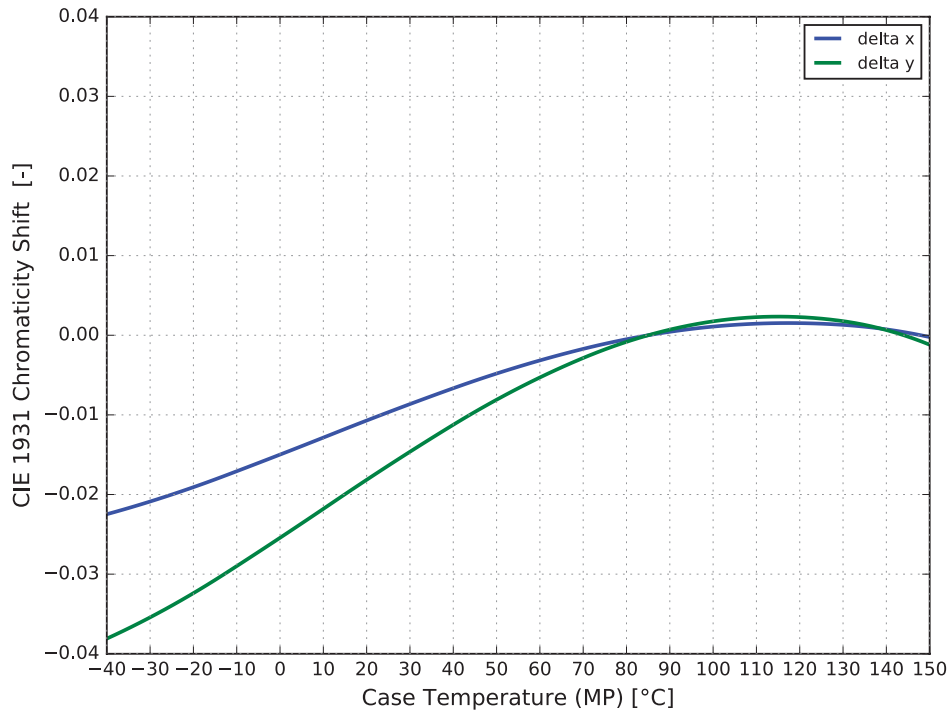

Figure 4a. Typical color shift in CIE 1931 x and y coordinates for LUXEON Altilon SMD at 1000mA, 20ms MP.

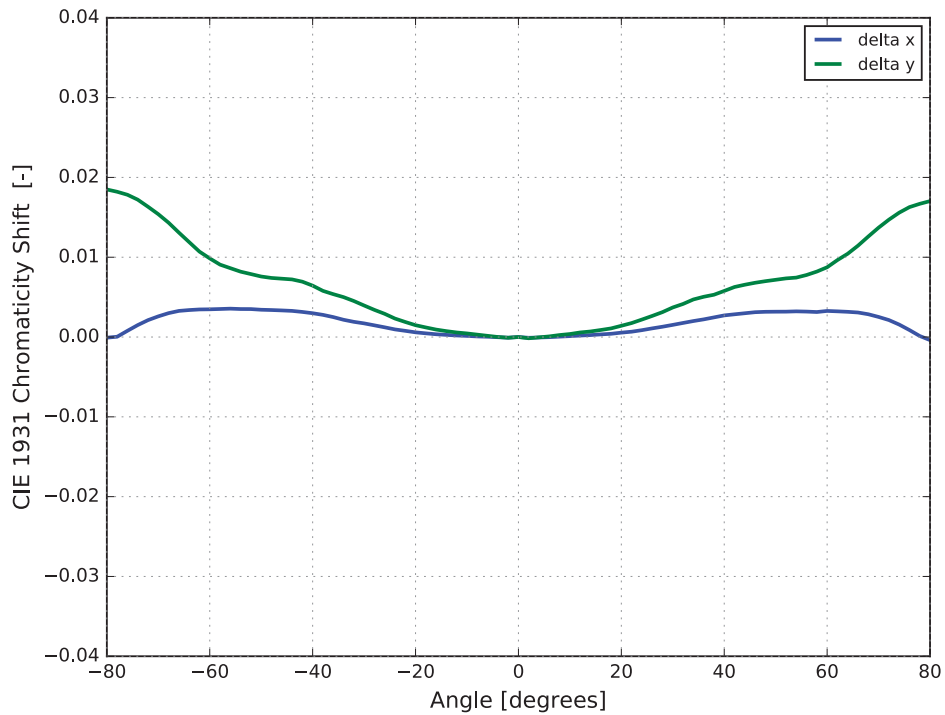

Figure 4b. Typical color shift over angle for LUXEON Altilon SMD at 1000mA, 20ms MP, $T_c=85^\circ\text{C}$.

Radiation Pattern Characteristics

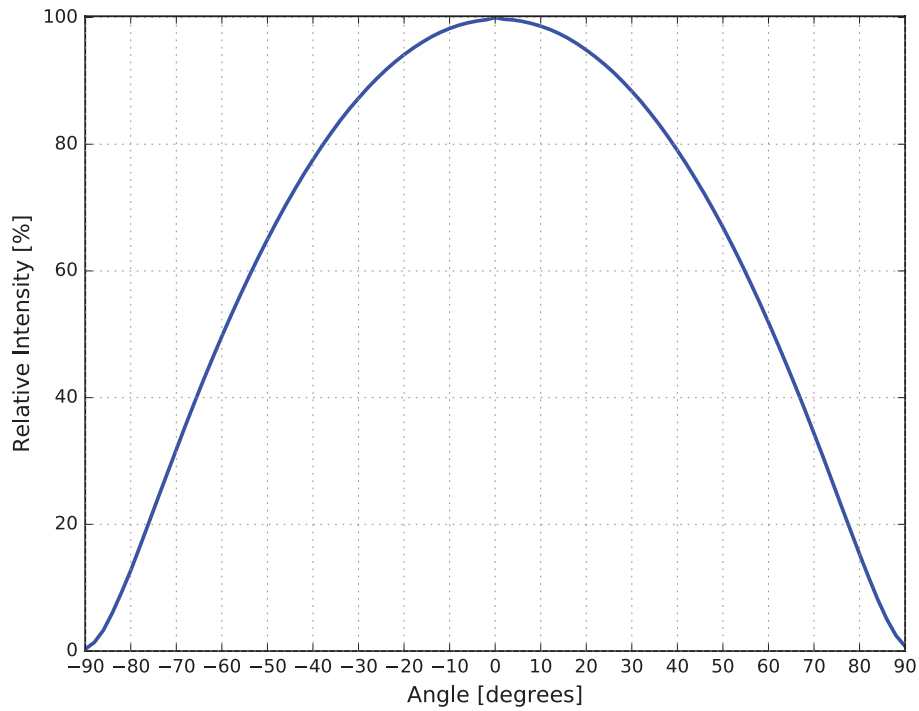

Figure 5. Typical radiation pattern for LUXEON Altilon SMD at 1000mA, 20ms MP.

Operating Limits Characteristics

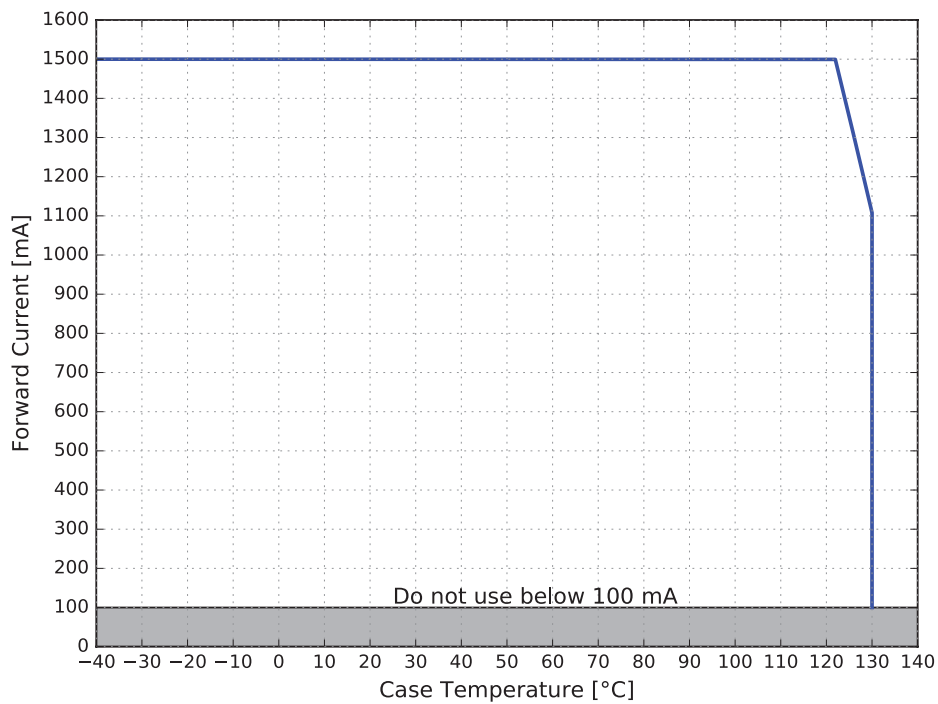

Figure 6. Maximum forward current vs. case temperature for LUXEON Altilon SMD.

Product Bin and Labeling Definitions

Designing with LUXEON Altilon SMD

Flux bins supportable for car programs depend on product color and program start- and end-of-production date. Flux roadmaps by year and product color are maintained and available from the sales representative. Please contact a local sales representative to request the flux bin range with best supportability for program timing.

Decoding Product Bin Labeling

In the manufacturing of semiconductor products, there are variations in performance around the average values given in the technical datasheets. For this reason, Lumileds bins the LED components for luminous flux or radiometric power, forward voltage, color point, peak wavelength, or dominant wavelength.

The CAT code identifies the flux and color bin of each part. The CAT code can be found in two distinct places, the package label and the TnR label. LUXEON Altilon SMD LEDs are labeled using a 4-digit alphanumeric CAT code following the format below:

A B C D

Where:

- A** – designates minimum luminous flux per die (M=340, N=350, P=360, etc.)
- B** – designates number of die (2, 3, 4 or 5)
- C D** – designates color bin (example: HC)

Therefore, a LUXEON Altilon SMD with a lumen range of 640 to 660, color bin of HC, and a forward voltage range of 6.40V to 7.00V has the following CAT code:

M 5 H C

Luminous Flux Bins

Table 5 lists the standard luminous flux bins for LUXEON Altilon SMD emitters. Product availability in a particular bin varies by color and platform start of production date. Contact your local sales representative for best supportability of programs.

Table 5a. Luminous flux bin definitions for LUXEON Altilon SMD at 1000mA, 20ms MP, T_c=85°C.

BIN	LUMINOUS FLUX ⁽¹⁾ (lm) PER DIE	
	MINIMUM	MAXIMUM
K	320	330
L	330	340
M	340	350
N	350	360
P	360	370
Q	370	380

Notes for Table 5:

1. Lumileds maintains a tolerance of ±6.5% on luminous flux measurements.
2. Product availability in a particular bin varies by color and platform start of production date.
3. Contact local sales representative for best supportability of programs.

Table 5b. Luminous flux bin definitions for LUXEON Altilon SMD at 1000mA, 20ms MP, T_c=85°C.

BIN	2 (1x2)	3 (1x3)	4 (1x4)	5 (1x5)
K	640	960	1280	1600
L	660	990	1320	1650
M	680	1020	1360	1700
N	700	1050	1400	1750
P	720	1080	1440	1800
Q	740	1110	1480	1850

The total flux bin is defined on a per die basis, the first letter on the flux bin will define the minimum flux per die and the second letter will define the number of die in the device, i.e. C4 where C will designate a minimum flux per die of 250 lm and 4 will designate that the part has four die, therefore the total flux from the device will be a minimum of 1000 lm.

This will allow for better flux bin granularity, as a 1x2 will have 20 lm flux bin increments, a 1x3 30 lm, a 1x4 40 lm and a 1x5 50 lm. The flux bin is defined on the total flux of the device as die are not individually measured.

Color Bin Structure

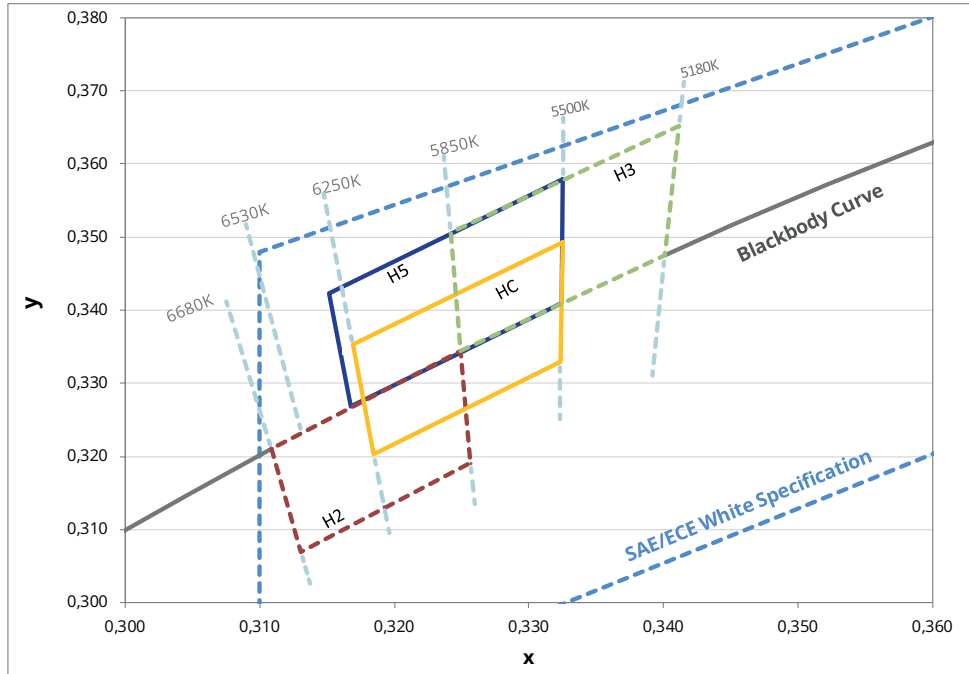

Figure 7. Color bin structure in CIE 1931 color space for LUXEON Altilon SMD at 1000mA, 20ms MP, $T_c=85^\circ\text{C}$.

Notes for Figure 7:

1. Lumileds supports the following bins for LUXEON Altilon SMD: H2, H3, HC, H5

Color Bin Definitions

Table 6a. Color bin definitions for LUXEON Altilon SMD.

BIN	$x^{[1, 2]}$	$y^{[1, 2]}$	6-DIGIT IEC CODE	TYPICAL CCT
HC	0.3325	0.3493		5850
	0.3169	0.3353		
	0.3185	0.3203		
H5	0.3323	0.3329		5900
	0.3325	0.3579		
	0.3151	0.3423		
	0.3168	0.3268		
H2	0.3324	0.3410		6250
	0.3109	0.3211		
	0.3131	0.3070		
H3	0.3256	0.3191		5500
	0.3249	0.3344		
	0.3249	0.3344		
	0.3401	0.3476		
H3	0.3412	0.3652		5180
	0.3242	0.3506		

Notes for Table 6a:

1. LUXEON Altilon SMD emitters are tested and binned by x and y coordinates.
 2. Lumileds maintains a tester tolerance of ± 0.005 on x and y coordinates.

Table 6b. Optional color bin definitions for LUXEON Altilon SMD at 1000mA 20ms MP, T_c=85°C.

CODE	x ^[1, 2]	y ^[1, 2]	TYPICAL CCT	CODE	x ^[1, 2]	y ^[1, 2]	TYPICAL CCT
1A	0.3109	0.3382	6390K	3A	0.3242	0.3506	5680K
	0.3161	0.3432			0.3325	0.3579	
	0.3169	0.3353			0.3325	0.3493	
	0.3120	0.3306			0.3246	0.3424	
1B	0.3120	0.3306	6390K	3B	0.3246	0.3424	5680K
	0.3169	0.3353			0.3325	0.3493	
	0.3177	0.3277			0.3324	0.3410	
	0.3131	0.3232			0.3249	0.3344	
1C	0.3161	0.3432	6050K	3C	0.3325	0.3579	5350K
	0.3242	0.3506			0.3412	0.3652	
	0.3246	0.3424			0.3406	0.3562	
	0.3169	0.3353			0.3325	0.3493	
1D	0.3169	0.3353	6050K	3D	0.3325	0.3493	5350K
	0.3246	0.3424			0.3406	0.3562	
	0.3249	0.3344			0.3401	0.3476	
	0.3177	0.3277			0.3324	0.3410	
2A	0.3109	0.3211	6460K	4A	0.3249	0.3344	5680K
	0.3177	0.3277			0.3324	0.3410	
	0.3185	0.3203			0.3323	0.3329	
	0.3120	0.3139			0.3253	0.3266	
2B	0.3120	0.3139	6460K	4B	0.3253	0.3266	5680K
	0.3185	0.3203			0.3323	0.3329	
	0.3192	0.3131			0.3323	0.3251	
	0.3131	0.3070			0.3256	0.3191	
2C	0.3177	0.3277	6050K	4C	0.3324	0.3410	5350K
	0.3249	0.3344			0.3401	0.3476	
	0.3253	0.3266			0.3396	0.3392	
	0.3185	0.3203			0.3323	0.3329	
2D	0.3185	0.3203	6050K	4D	0.3323	0.3329	5350K
	0.3253	0.3266			0.3396	0.3392	
	0.3256	0.3191			0.3392	0.3310	
	0.3192	0.3131			0.3323	0.3251	
1E	0.3169	0.3353	5970K	1F	0.3208	0.3388	5780K
	0.3285	0.3458			0.3325	0.3493	
	0.3288	0.3298			0.3323	0.3329	
	0.3185	0.3203			0.3219	0.3234	

Notes for Table 6b:

- LUXEON Altilon SMD emitters are tested and binned by x and y coordinates.
- Lumileds maintains a tester tolerance of ±0.005 on x and y coordinates.

Mechanical Dimensions

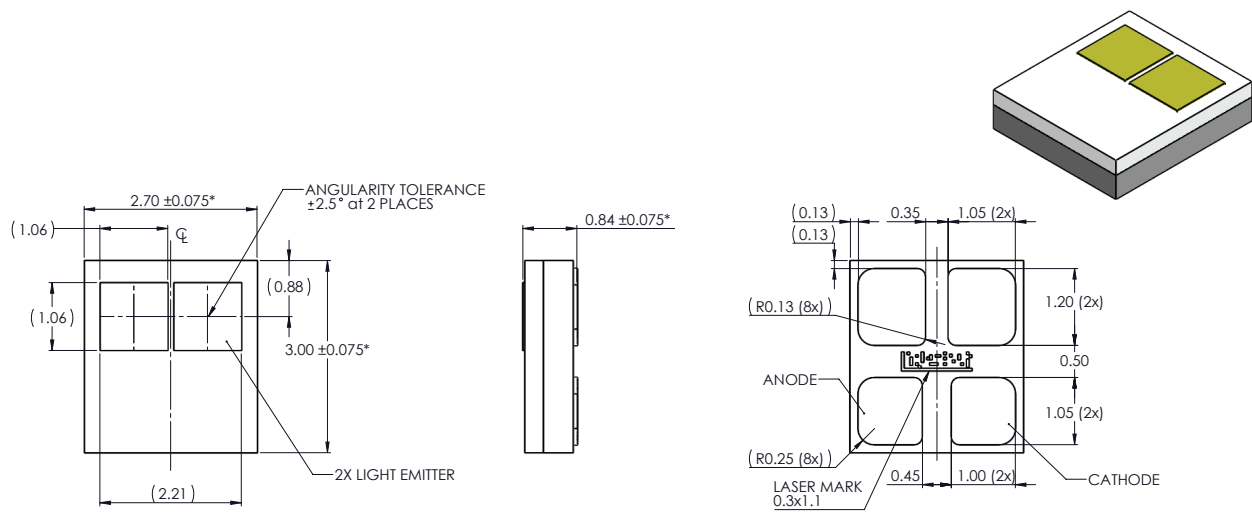

Figure 8a. Mechanical dimensions for LUXEON Altilon SMD 1x2.

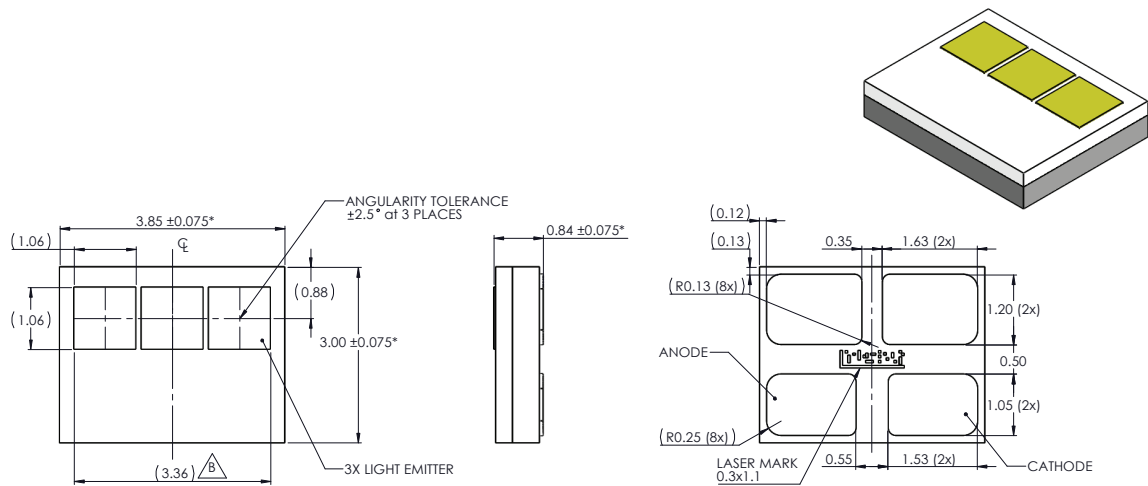

Figure 8b. Mechanical dimensions for LUXEON Altilon SMD 1x3.

Notes for Figures 8a and 8b:

1. Drawings are not to scale.
2. All dimensions are in millimeters.

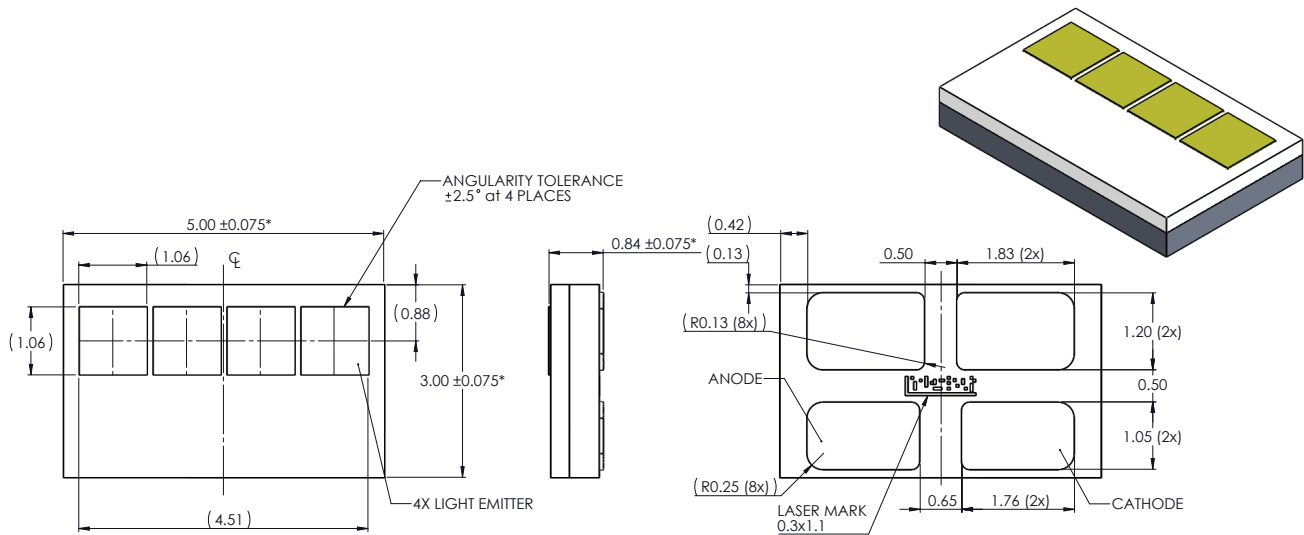

Figure 8c. Mechanical dimensions for LUXEON Altilon SMD 1x4.

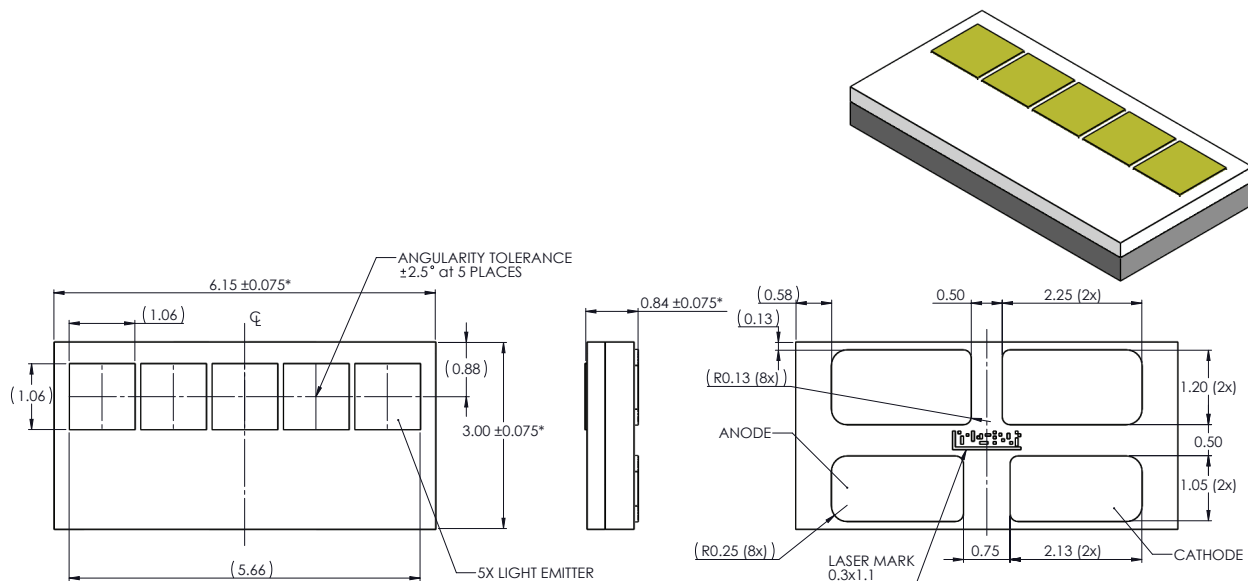

Figure 8d. Mechanical dimensions for LUXEON Altilon SMD 1x5.

Notes for Figures 8c and 8d:

1. Drawings are not to scale.
2. All dimensions are in millimeters.

Reflow Soldering Guidelines

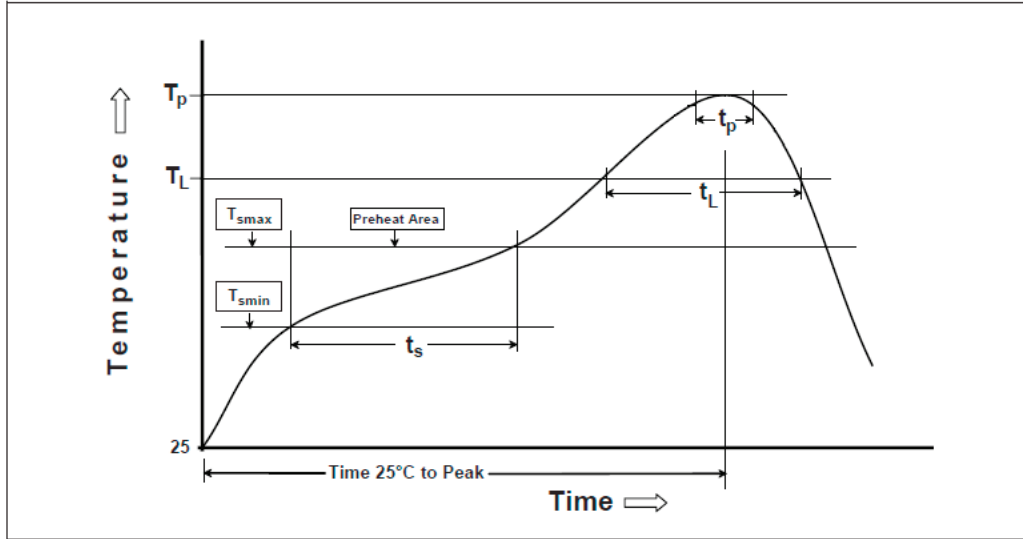

Figure 9. Visualization of the acceptable reflow temperature profile as specified in Table 7.

Table 7. Reflow profile characteristics for LUXEON Altilon SMD.

PROFILE FEATURE	LEAD FREE ASSEMBLY
Preheat Minimum Temperature (T_{smin})	150°C
Preheat Maximum Temperature (T_{smax})	200°C
Preheat Time (t_{smin} to t_{smax})	60 to 180 seconds
Ramp-Up Rate (T_{smax} to T_p)	3°C / second maximum
Liquidus Temperature (T_L)	217°C
Time Maintained Above Temperature T_L (t_L)	60 to 150 seconds
Peak / Classification Temperature (T_p)	260°C
Time Within 5°C of Actual Temperature (t_p)	20 to 40 seconds
Ramp-Down Rate	6°C / second maximum
Time 25°C to Peak Temperature	8 minutes maximum

Notes for Table 7:

1. All temperatures refer to the application Printed Circuit Board (PCB), measured on the surface adjacent to the package body.

JEDEC Moisture Sensitivity

Table 8. Moisture sensitivity levels for LUXEON Altilon SMD.

LEVEL	FLOOR LIFE	
	TIME	CONDITIONS
1	Unlimited	≤30°C / 85% RH

Solder Pad Design

Details for recommended solder pad designs that provide low thermal resistance will be published in a separate application brief. These recommendations are not intended to represent specifications for soldering LUXEON Altilon SMD LEDs.

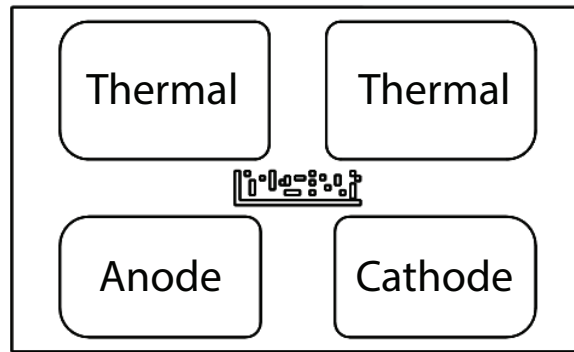

Figure 10. Recommended PCB solder pad layout for LUXEON Altilon SMD.

Notes for Figure 10:

1. All dimensions are in millimeters.
2. The thermal pads are electrically isolated from the anode and cathode contact pads.

Packaging Information

Pocket Tape Dimensions

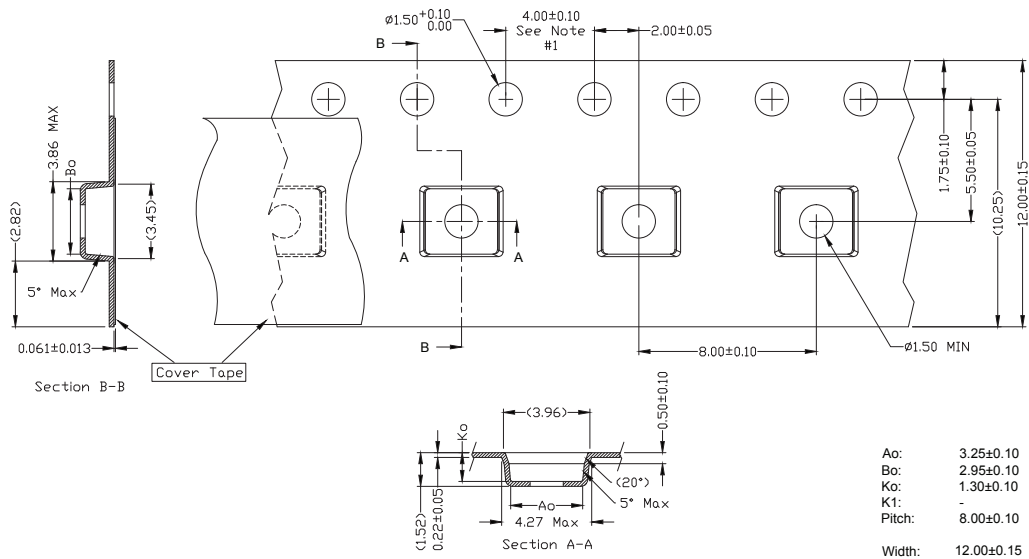

Figure 11a. Pocket tape dimensions for LUXEON Altilon SMD 1x2.

Notes for Figure 11a:

1. Drawings are not to scale.
2. All dimensions are in millimeters.

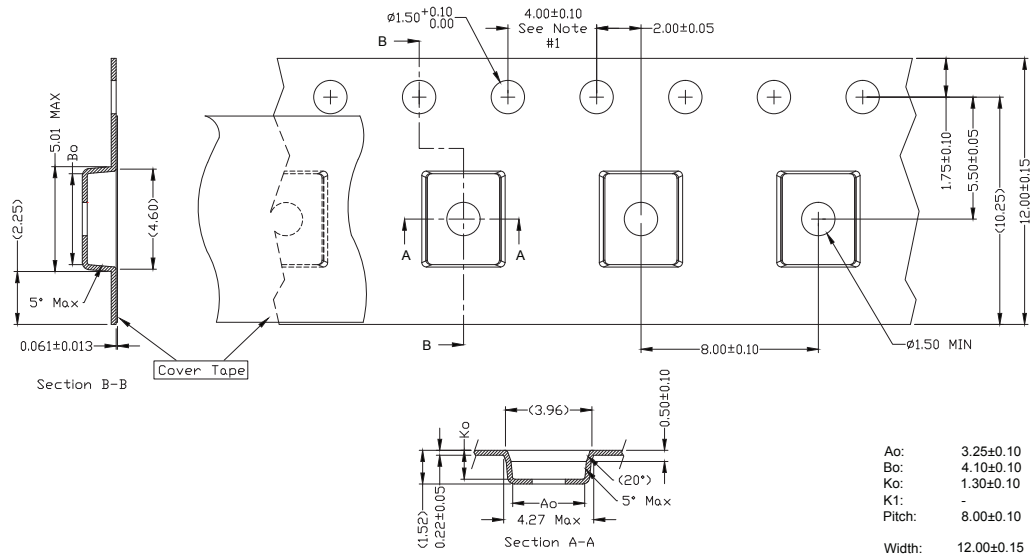

Figure 11b. Pocket tape dimensions for LUXEON Altilon SMD 1x3.

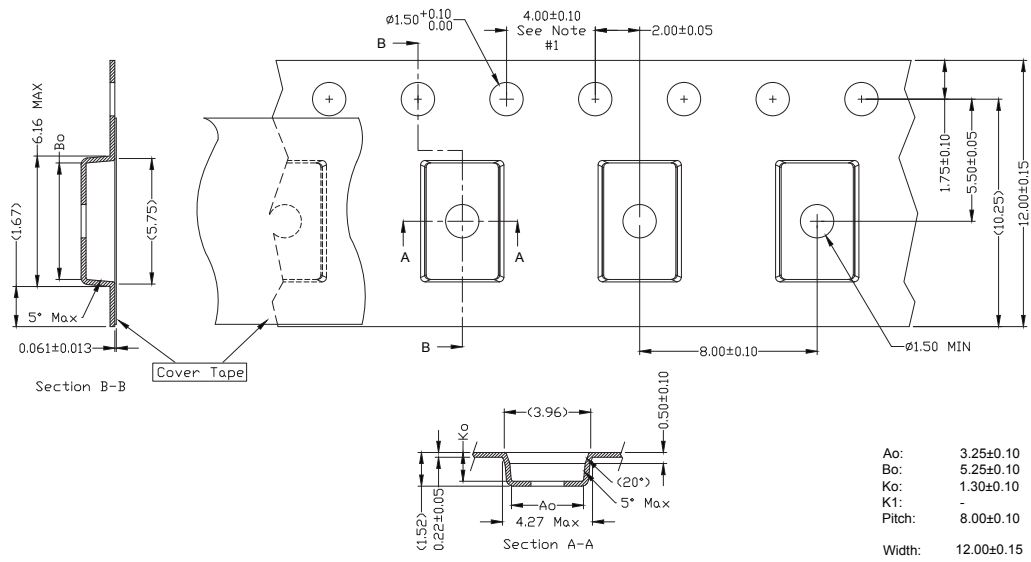

Figure 11c. Pocket tape dimensions for LUXEON Altilon SMD 1x4.

- Notes for Figures 11b and 11c:
1. Drawings are not to scale.
 2. All dimensions are in millimeters.

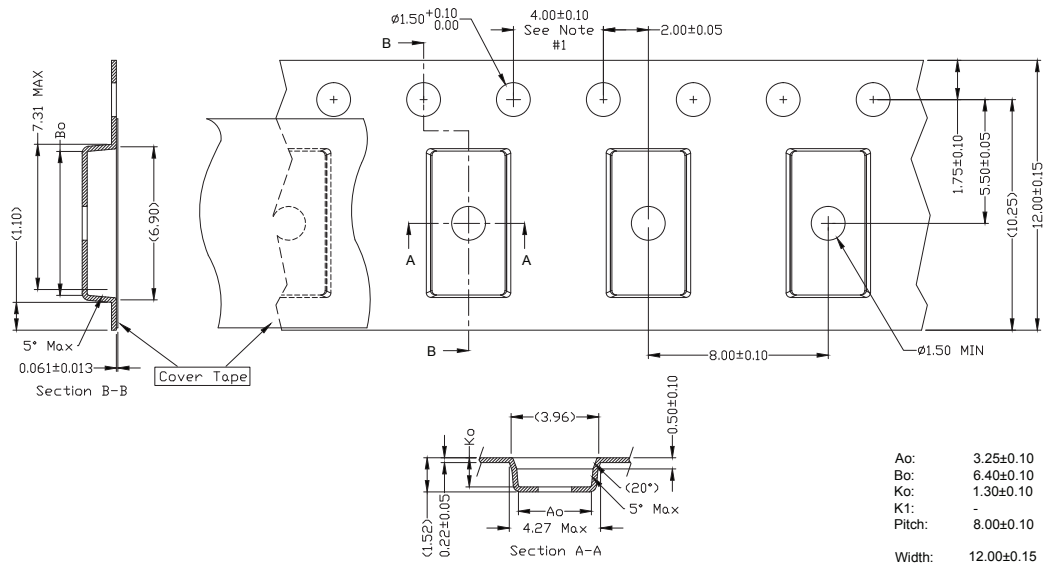

Figure 11d. Pocket tape dimensions for LUXEON Altalon SMD 1x5.

Notes for Figure 11d:

1. Drawings are not to scale.
2. All dimensions are in millimeters.

Reel Dimensions

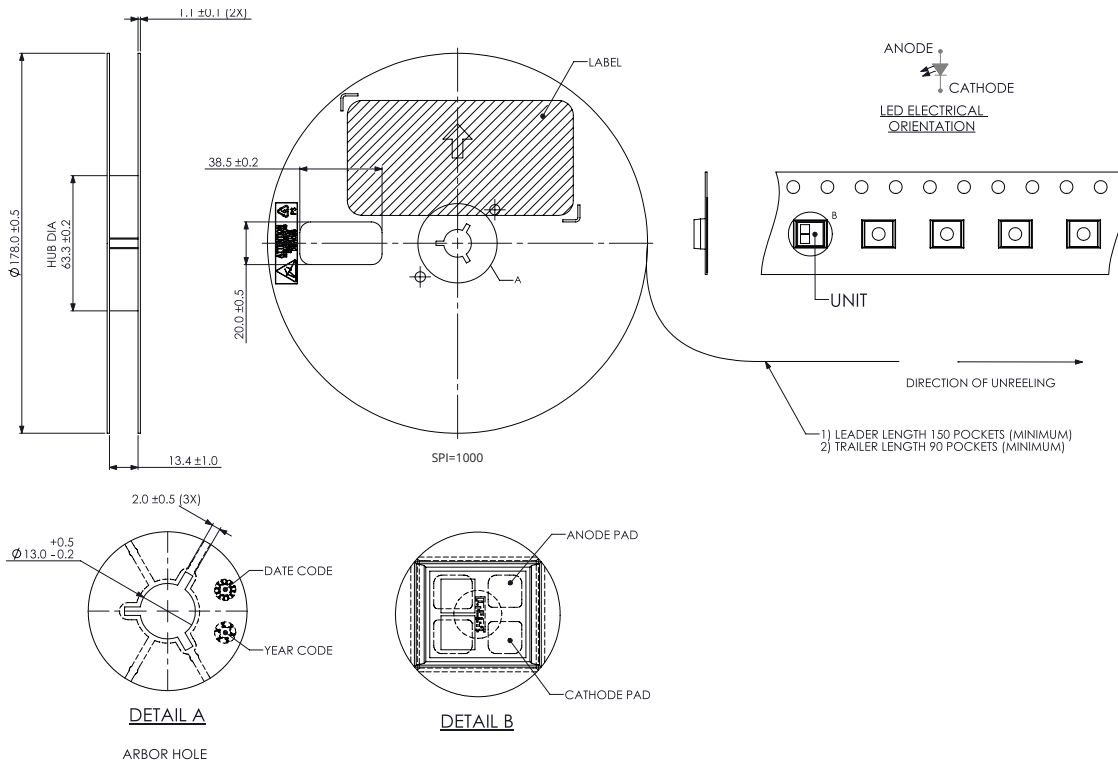

Figure 12a. Reel dimensions for LUXEON Altalon SMD 1x2.

Notes for Figure 12a:

1. Drawings are not to scale.
2. All dimensions are in millimeters.
3. SPI=1000 (SPI is the number of LEDs per reel). For Altalon SMD, all reels ship with 1000 LEDs.

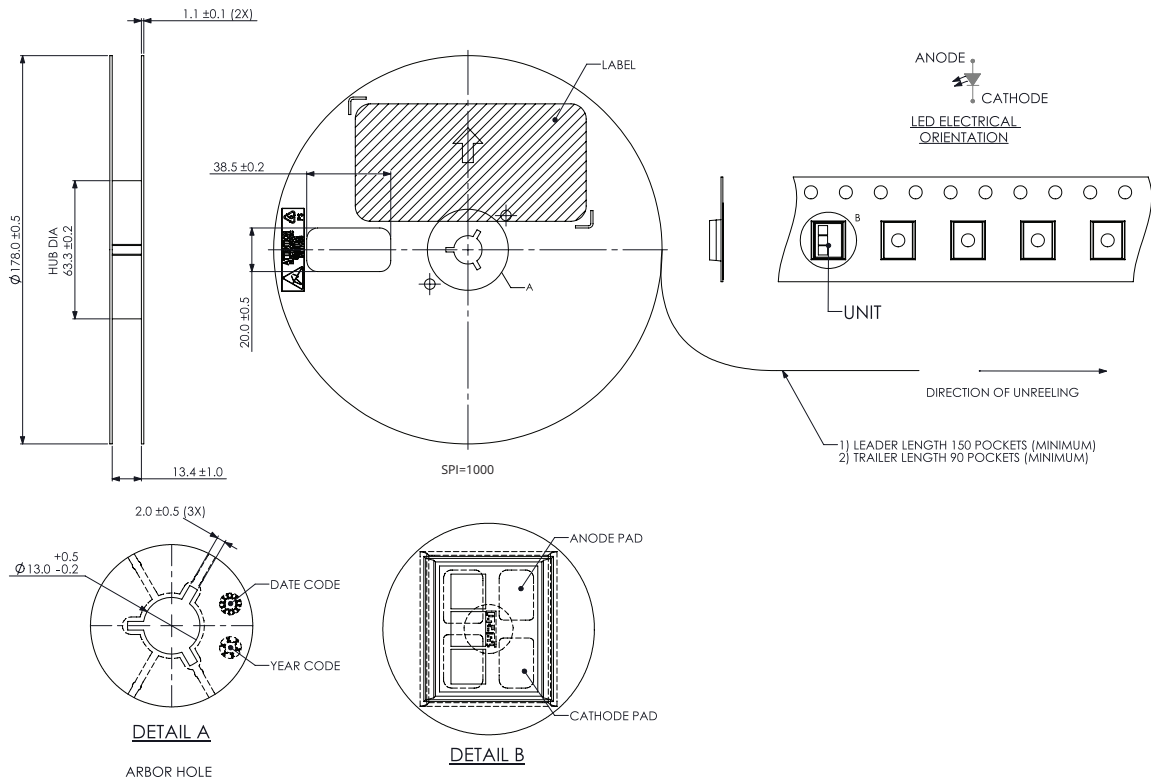

Figure 12b. Reel dimensions for LUXEON Altilon SMD 1x3.

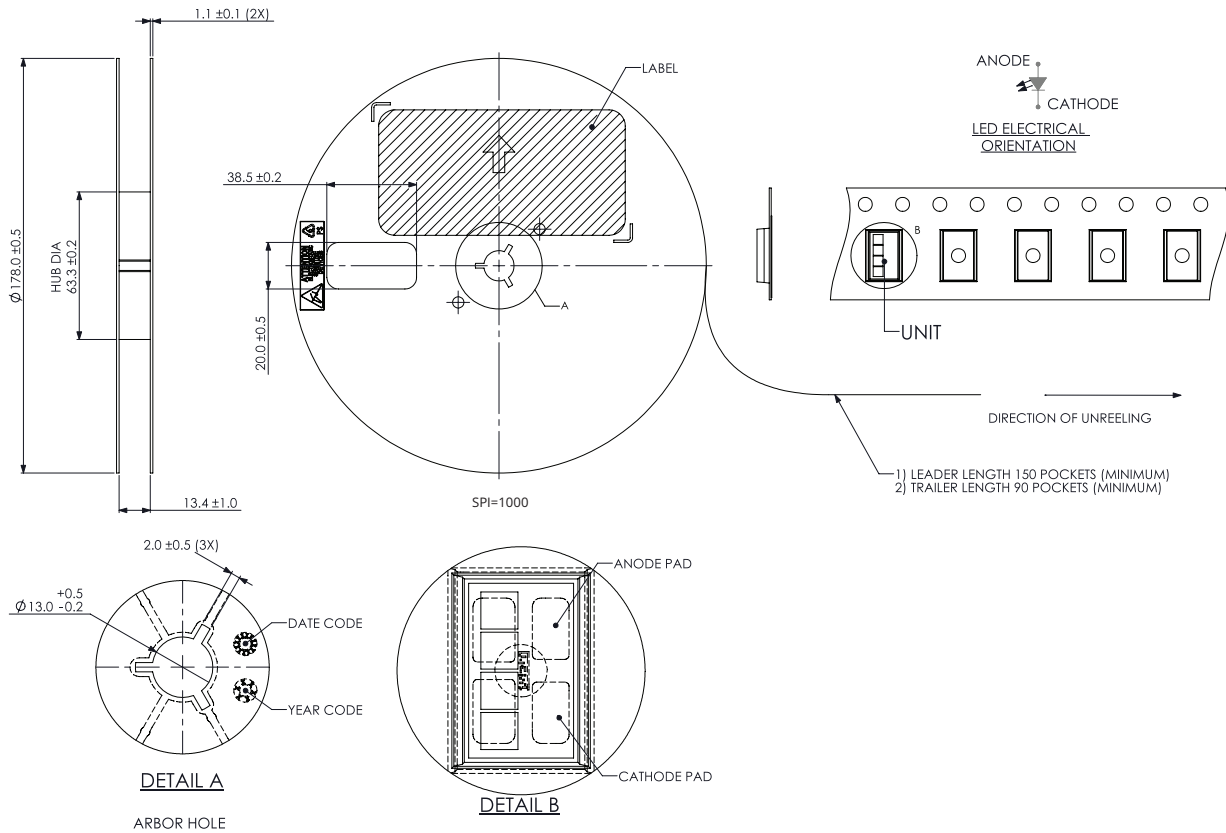

Figure 12c. Reel dimensions for LUXEON Altilon SMD 1x4.

Notes for Figures 12b and 12c:

1. Drawings are not to scale.
2. All dimensions are in millimeters.
3. SPI=1000 (SPI is the number of LEDs per reel). For Altilon SMD, all reels ship with 1000 LEDs.

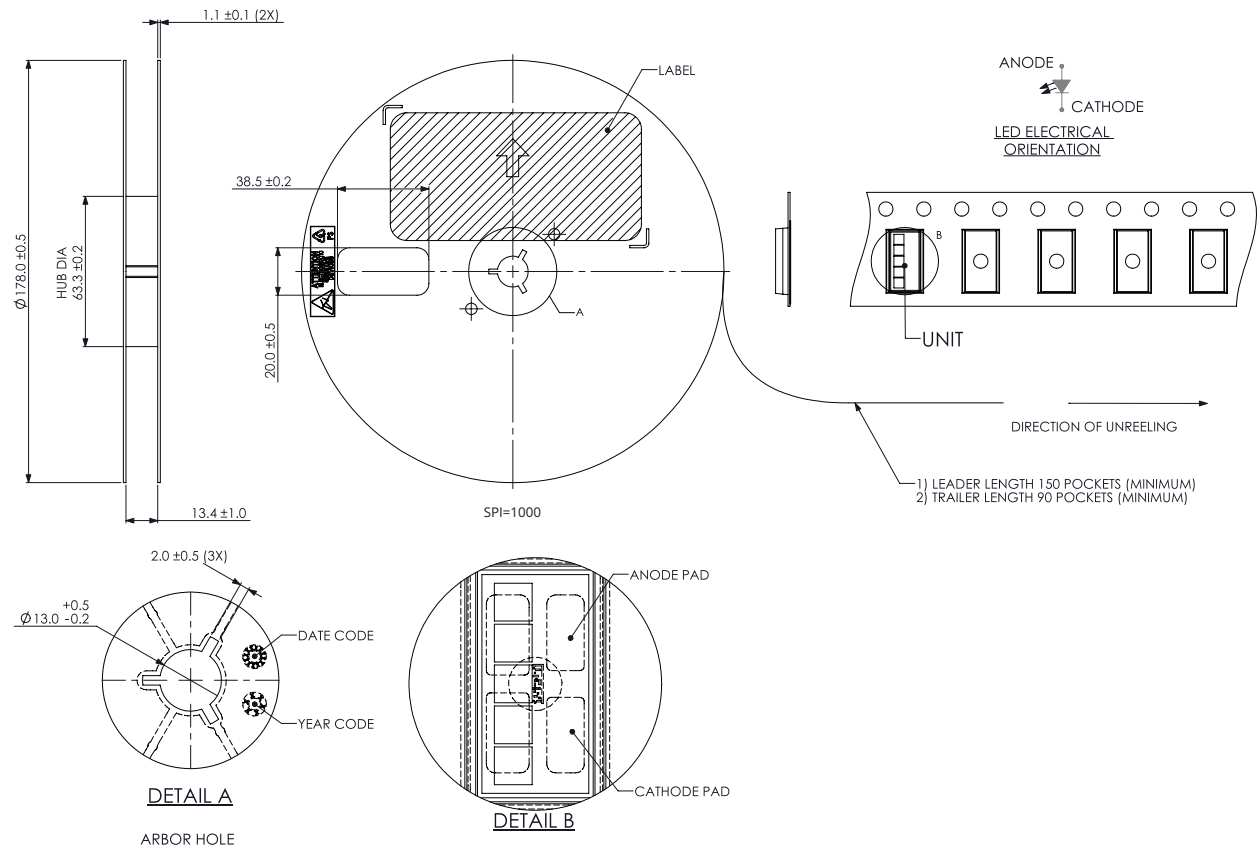

Figure 12d. Reel dimensions for LUXEON Altilon SMD 1x5.

Notes for Figure 12d:

1. Drawings are not to scale.
2. All dimensions are in millimeters.
3. SPI=1000 (SPI is the number of LEDs per reel). For Altilon SMD, all reels ship with 1000 LEDs.

Product Labeling

LUXEON Altilon SMD LEDs are packaged in moisture barrier bags on reels. Both moisture barrier bag and reels have printed information providing part numbers with CAT codes that indicate luminous flux, color and forward voltage bins.

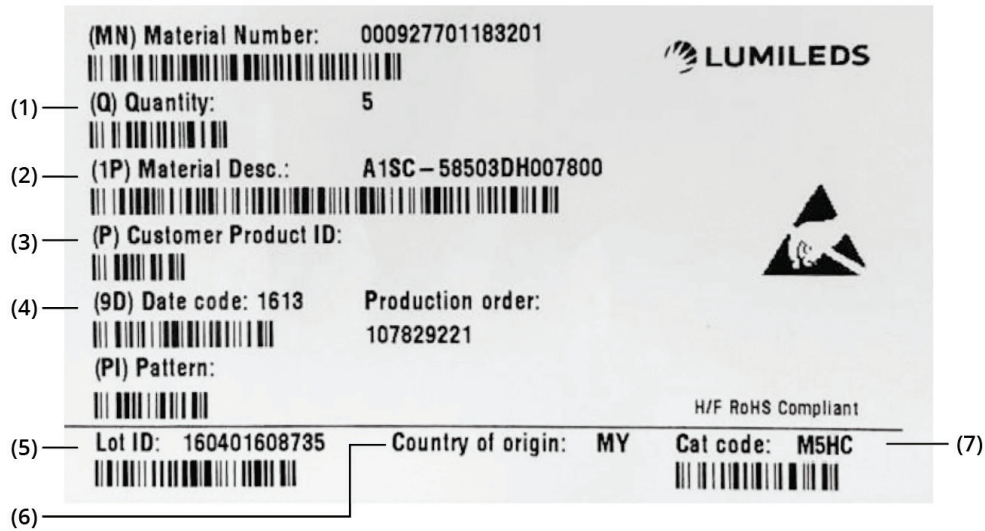

Figure 13. Example of a product label for LUXEON Altilon SMD.

Notes for Figure 13 – Outer Box Label descriptions for customer use:

Field labels not described are for Lumileds internal use only.

1. Total number of LED emitters in a shipment box.
2. Lumileds part number
3. Customer part number for custom requests only.
4. LED test date in YYYY format.
5. Unique product lot identification number. This number is required for traceability purposes.
6. Country code of origin of manufacturing of part (e.g. MY for Malaysia, CN for China) according to ISO 3166-1 alpha-2 document.
7. Product bin 4-digit alphanumeric CAT code.

About Lumileds

Companies developing automotive, mobile, IoT and illumination lighting applications need a partner who can collaborate with them to push the boundaries of light. With over 100 years of inventions and industry firsts, Lumileds is a global lighting solutions company that helps customers around the world deliver differentiated solutions to gain and maintain a competitive edge. As the inventor of Xenon technology, a pioneer in halogen lighting and the leader in high performance LEDs, Lumileds builds innovation, quality and reliability into its technology, products and every customer engagement. Together with its customers, Lumileds is making the world better, safer, more beautiful—with light.

To learn more about our lighting solutions, visit lumileds.com.



©2020 Lumileds Holding B.V. All rights reserved.
LUXEON is a registered trademark of the Lumileds Holding B.V. in the United States and other countries.

lumileds.com

Neither Lumileds Holding B.V. nor its affiliates shall be liable for any kind of loss of data or any other damages, direct, indirect or consequential, resulting from the use of the provided information and data. Although Lumileds Holding B.V. and/or its affiliates have attempted to provide the most accurate information and data, the materials and services information and data are provided "as is," and neither Lumileds Holding B.V. nor its affiliates warrants or guarantees the contents and correctness of the provided information and data. Lumileds Holding B.V. and its affiliates reserve the right to make changes without notice. You as user agree to this disclaimer and user agreement with the download or use of the provided materials, information and data. A listing of Lumileds product/patent coverage may be accessed at lumileds.com/patents.