

LUXEON C ES Color Line

Maximum density and minimal area for complex color arrays

LUXEON C ES Color Line is designed specifically for use in large LED arrays under a single optic. Its larger die and small package enable the total array area to be minimized, and LED arrangement optimized while delivering high light output. The three-stripe pad enables complex electronic circuits and provides superior thermal management connections. For entertainment, architectural, and EVL applications where significant output from large arrays is desired, LUXEON C ES is the clear choice.

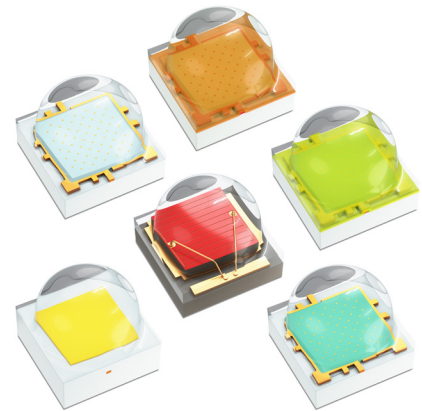

FEATURES AND BENEFITS

Best in class for multi-color array mixing with minimum LED-to-LED spacing needed for placement

The 3-stripe footprint, offers the flexibility of design in a complex routing as it shortened electrodes for routing between LEDs while keeping LEDs maximally close-packed

Large die in a small package provides high flux, low V_f , and low $P_{thermal}$

High drive current enables output to be maximized and LED count minimized

Large thermal pad allows high drive currents and makes it possible to create close-packed LED clusters

Superior reliability from a proven, robust package

PRIMARY APPLICATIONS

Spotlights

Wall Wash

Floodlights

Landscape Lighting

[More...](#)



Table of Contents

General Product Information	2
Product Test Conditions	2
Part Number Nomenclature	2
Lumen Maintenance	2
Environmental Compliance	2
Performance Characteristics	3
Product Selection Guide	3
Optical Characteristics	4
Electrical and Thermal Characteristics	5
Absolute Maximum Ratings	5
Characteristic Curves	6
Spectral Power Distribution Characteristics	6
Light Output Characteristics	8
Forward Current Characteristics	14
Radiation Pattern Characteristics	16
Product Bin and Labeling Definitions	19
Decoding Product Bin Labeling	19
Luminous Flux Bins	20
Radiometric Power Bins	21
Color Bin Definitions	22
Peak Wavelength Bins	25
Dominant Wavelength Bins	25
Forward Voltage Bins	26
Mechanical Dimensions	26
Reflow Soldering Guidelines	27
JEDEC Moisture Sensitivity	27
Solder Pad Design	28
Packaging Information	28
Pocket Tape Dimensions	28
Reel Dimensions	29
About Lumileds	30

General Product Information

Product Test Conditions

LUXEON C ES Color Line LEDs are tested and binned with a DC drive current of 1000mA at a junction temperature, T_j , of 85°C.

Part Number Nomenclature

Part numbers for LUXEON C ES Color Line follow the convention below:

L 1 C 2 – **A A A** 1 0 0 0 0 0 0 0 0 0

Where:

A A A – designates color (DRD=Deep Red, RED=Red, PCA=PC Amber, MNT=Mint, LME=Lime, GRN=Green, CYN=Cyan, BLU=Blue, RYL=Royal Blue)

Therefore, the following part number is used for a LUXEON C ES Red LED:

L 1 C 2 – **R E D** 1 0 0 0 0 0 0 0 0 0

Part numbers for LUXEON C ES White follow the convention below:

L 1 C 2 – **A A B B** 0 0 0 0 0 0 0 0 0 0

Where:

A A – designates nominal CCT (27=2700K, 30=3000K, 40=4000K, 57=5700K)

B B – designates minimum CRI (70=70CRI, 80=80CRI)

Therefore, the following part number is used for a LUXEON C ES White 4000K 80CRI LED:

L 1 C 2 – **4 0 8 0** 0 0 0 0 0 0 0 0 0 0

Lumen Maintenance

Please contact your local Sales Representative or Lumileds Technical Solutions Manager for more information about the long-term performance of this product.

Environmental Compliance

Lumileds Holding B.V. is committed to providing environmentally friendly products to the solid-state lighting market. LUXEON C ES Color Line is compliant to the European Union directives on the restriction of hazardous substances in electronic equipment, namely the RoHS Directive 2011/65/EU and REACH Regulation (EC) 1907/2006. Lumileds Holding B.V. will not intentionally add the following restricted materials to its products: lead, mercury, cadmium, hexavalent chromium, polybrominated biphenyls (PBB) or polybrominated diphenyl ethers (PBDE).

Performance Characteristics

Product Selection Guide

Table 1a. Product performance of LUXEON C ES Colors at specified test current 1000mA, T_j=85°C

COLOR	DOMINANT OR PEAK WAVELENGTH ^[1] (nm)		LUMINOUS FLUX (lm) OR RADIOMETRIC POWER ^[2] (mW)		PART NUMBER
	MINIMUM	MAXIMUM	MINIMUM	TYPICAL	
Deep Red	655	675	935	1100	L1C2-DRD1000000000
Red	624	634	106	125	L1C2-RED1000000000
PC Amber	-	-	264	310	L1C2-PCA1000000000
Mint	-	-	391	460	L1C2-MNT1000000000
Lime	-	-	425	500	L1C2-LME1000000000
Green	520	540	298	350	L1C2-GRN1000000000
Cyan	490	510	204	240	L1C2-CYN1000000000
Blue	465	485	94	110	L1C2-BLU1000000000
Royal Blue	440	460	1275	1500	L1C2-RYL1000000000

Notes for Table 1a:

- Lumileds maintains a tolerance of ±6.5% on luminous flux measurements. PC Amber, Mint and Lime are binned by chromaticity coordinates. Deep Red and Royal Blue are binned by peak wavelength. All other colors are binned by dominant wavelength.
- Deep Red and Royal Blue are binned by radiometric power. All other colors are binned by luminous flux.

Table 1b. Product performance of LUXEON C ES White at 1000mA, T_j=85°C

COLOR	NOMINAL CCT	MINIMUM CRI ^[1]	LUMINOUS FLUX ^[1] (lm)		TYPICAL LUMINOUS EFFICACY (lm/W)	PART NUMBER
			MINIMUM	TYPICAL		
White	5700K	70	325	385	131	L1C2-5770000000000
	2700K	80	270	320	108	L1C2-2780000000000
	3000K	80	285	335	114	L1C2-3080000000000
	4000K	80	305	360	122	L1C2-4080000000000
	5700K	80	305	360	122	L1C2-5780000000000

Notes for Table 1b:

- Lumileds maintains a tolerance of ±2 on CRI and ±6.5% on luminous flux measurements.

Optical Characteristics

Table 2a. Optical characteristics for LUXEON C ES Colors at 1000mA, T_j=85°C

COLOR	PART NUMBER	TYPICAL SPECTRAL HALF-WIDTH ^[1] (nm)	TYPICAL TEMPERATURE COEFFICIENT OF DOMINANT OR PEAK WAVELENGTH (nm/°C)	TYPICAL TOTAL INCLUDED ANGLE ^[2]	TYPICAL VIEWING ANGLE ^[3]
Deep Red	L1C2-DRD1000000000	22	0.16	144	116
Red	L1C2-RED1000000000	18	0.06	142	119
PC Amber	L1C2-PCA1000000000	76	-0.01	145	129
Mint	L1C2-MNT1000000000	116	0.00	138	125
Lime	L1C2-LME1000000000	105	0.01	146	131
Green	L1C2-GRN1000000000	33	0.04	147	123
Cyan	L1C2-CYN1000000000	28	0.03	146	122
Blue	L1C2-BLU1000000000	27	0.02	147	123
Royal Blue	L1C2-RYL1000000000	21	0.04	143	124

Notes for Table 2a:

1. Spectral half-width is the spectral bandwidth at 50% of the peak intensity.
2. Total angle at which 90% of total luminous flux is captured.
3. Viewing angle is the off axis angle from the LED centerline where the luminous intensity is ½ of the peak value.

Table 2b. Optical characteristics for LUXEON C ES White at 1000mA, T_j=85°C

COLOR	PART NUMBER	TYPICAL TOTAL INCLUDED ANGLE ^[1]	TYPICAL VIEWING ANGLE ^[2]
White	L1C2-xxx0000000000	146	126

Notes for Table 2b:

1. Total angle at which 90% of total luminous flux is captured.
2. Viewing angle is the off axis angle from the LED centerline where the luminous intensity is ½ of the peak value.

Electrical and Thermal Characteristics

Table 3. Electrical and thermal characteristics for LUXEON C ES Color Line at 1000mA, T_j=85°C

COLOR	PART NUMBER	FORWARD VOLTAGE ^[1] (V _f)			TYPICAL TEMPERATURE COEFFICIENT OF FORWARD VOLTAGE ^[2] (mV/°C)	TYPICAL THERMAL RESISTANCE—JUNCTION TO SOLDER PAD (°C/W)
		MINIMUM	TYPICAL	MAXIMUM		
Deep Red	L1C2-DRD1000000000	2.00	2.20	2.80	-0.7	1.4
Red	L1C2-RED1000000000	2.00	2.20	2.80	-1.5	1.8
PC Amber	L1C2-PCA1000000000	2.50	2.95	3.30	-1.8	2.6
Mint	L1C2-MNT1000000000	2.50	2.95	3.30	-1.8	2.2
Lime	L1C2-LME1000000000	2.50	2.95	3.30	-1.8	2.2
Green	L1C2-GRN1000000000	2.70	3.20	3.50	-3.2	2.8
Cyan	L1C2-CYN1000000000	2.70	3.37	3.50	-3.0	2.6
Blue	L1C2-BLU1000000000	2.70	3.37	3.50	-3.9	2.3
Royal Blue	L1C2-RYL1000000000	2.50	2.95	3.30	-1.8	1.7
White	L1C2-xxx000000000	2.50	2.95	3.30	-1.7	2.0

Notes for Table 3:

1. Lumileds maintains a tolerance of ±0.06V on forward voltage measurements.
2. Measured between 25°C and 85°C.

Absolute Maximum Ratings

Table 4. Absolute maximum ratings for LUXEON C ES Color Line

PARAMETERS	DEEP RED	RED AND PC AMBER	GREEN AND CYAN	BLUE AND ROYAL BLUE	MINT, LIME AND WHITE
DC Forward Current ^[1, 2]	1400mA	2100mA	2100mA	2100mA	2100mA
Peak Pulsed Forward Current ^[1, 3]	1750mA	2600mA	2600mA	2600mA	2600mA
LED Junction Temperature ^[1] (DC & Pulse)	135°C	135°C	135°C	135°C	135°C
ESD Sensitivity (ANSI/ESDA/JEDEC JS-001-2012)	Class 1A				
LED Storage Temperature	-40°C to 135°C				
Soldering Temperature	JEDEC 020D 260°C				
Allowable Reflow Cycles	3				
Reverse Voltage (V _{reverse})	LUXEON LEDs are not designed to be driven in reverse bias				

Notes for Table 4:

1. Proper current derating must be observed to maintain the junction temperature below the maximum allowable junction temperature.
2. Residual periodic variations due to power conversion from alternating current (AC) to direct current (DC), also called "ripple," are acceptable if the following conditions are met:
 - The frequency of the ripple current is 100Hz or higher
 - The average current for each cycle does not exceed the maximum allowable DC forward current
 - The maximum amplitude of the ripple does not exceed the maximum peak pulsed forward current
3. At 10% duty cycle with pulse width of 10ms.

Characteristic Curves

Spectral Power Distribution Characteristics

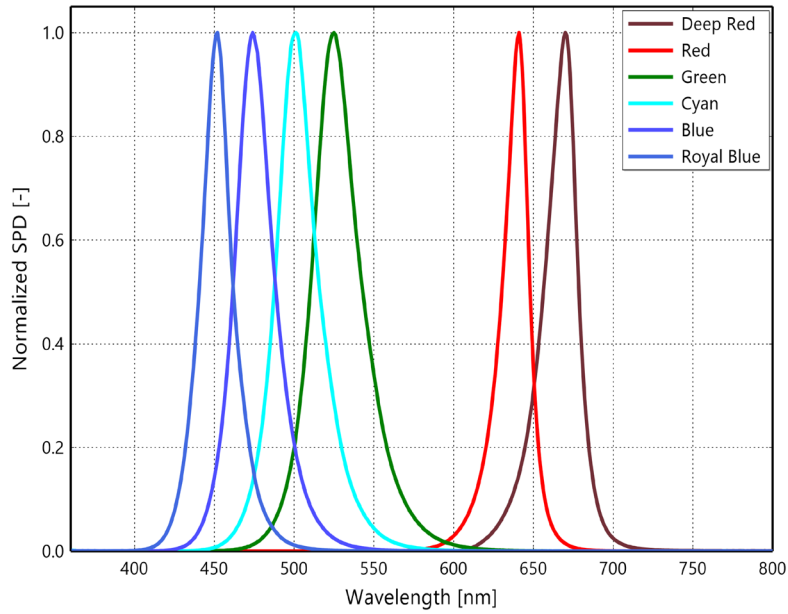

Figure 1a. Typical normalized SPD vs. wavelength for LUXEON C ES Direct Colors at 1000mA, $T_j=85^\circ\text{C}$

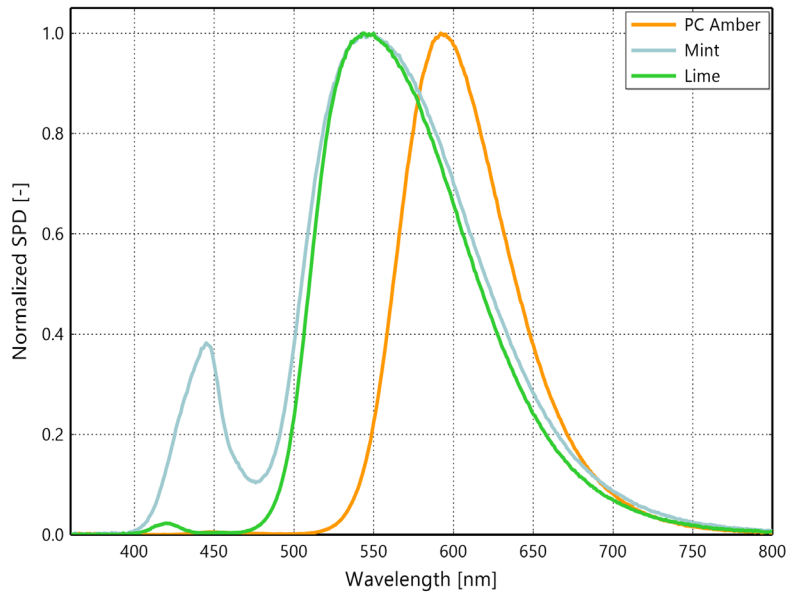

Figure 1b. Typical normalized SPD vs. wavelength for LUXEON C ES Phosphor Converted Colors at 1000mA, $T_j=85^\circ\text{C}$

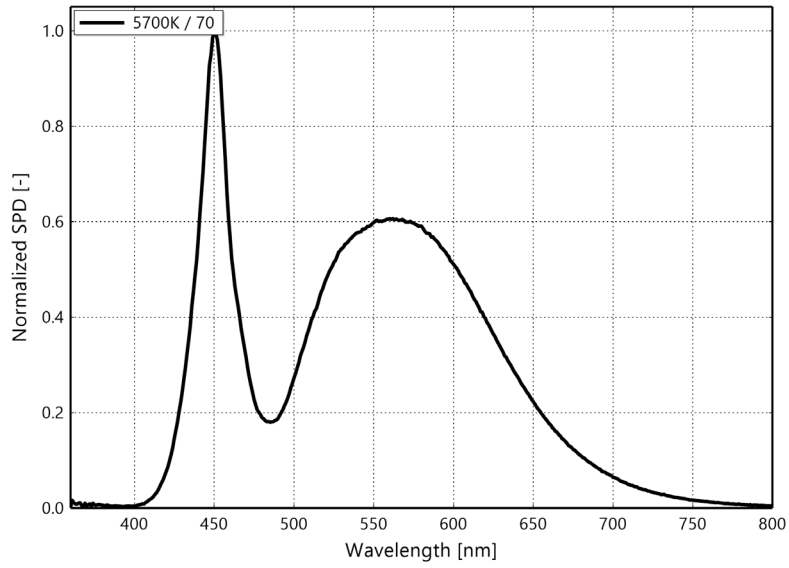

Figure 1c. Typical normalized SPD vs. wavelength for LUXEON C ES White 70CRI at 1000mA, $T_j=85^\circ\text{C}$

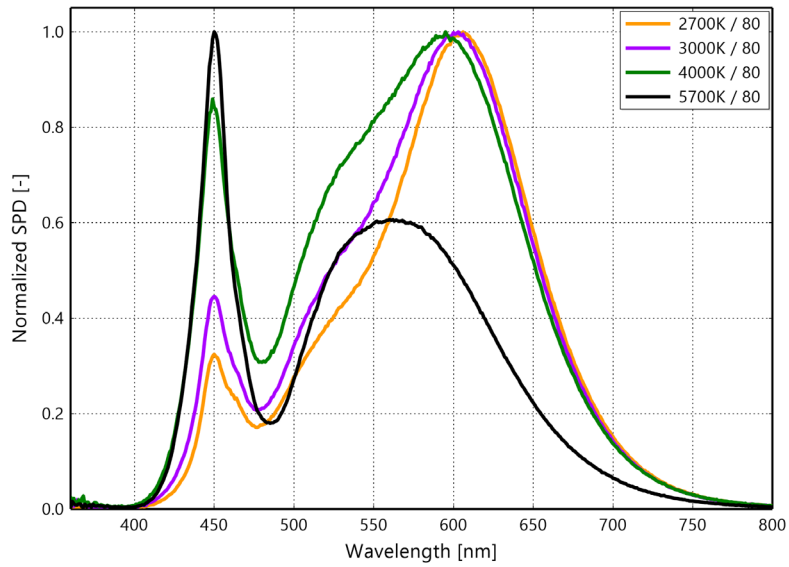

Figure 1d. Typical normalized SPD vs. wavelength for LUXEON C ES White 80CRI at 1000mA, $T_j=85^\circ\text{C}$

Light Output Characteristics

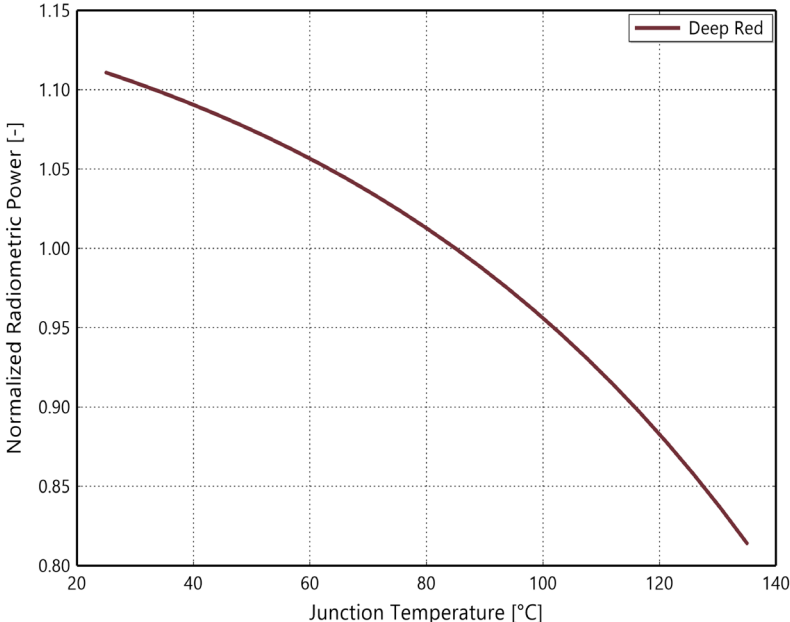

Figure 2a. Typical normalized radiometric power vs. junction temperature for LUXEON C ES Deep Red at 1000mA

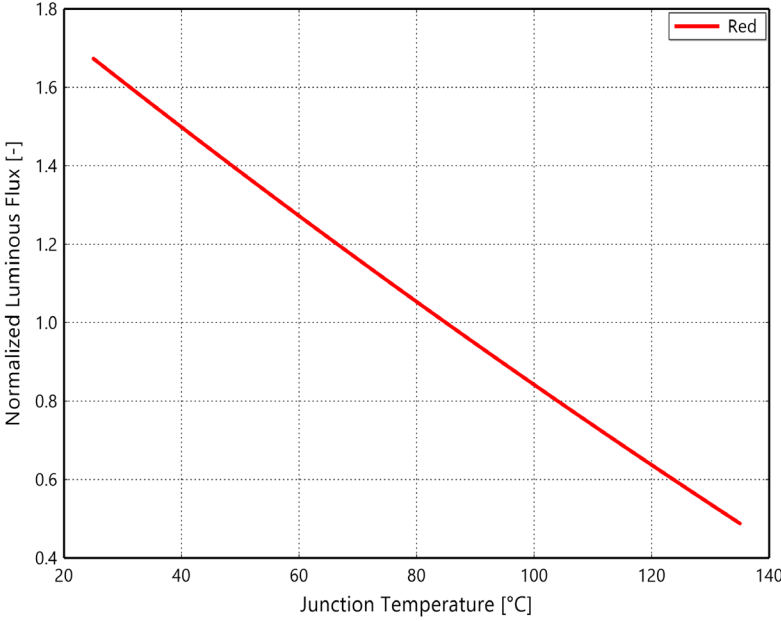

Figure 2b. Typical normalized luminous flux vs. junction temperature for LUXEON C ES Red at 1000mA

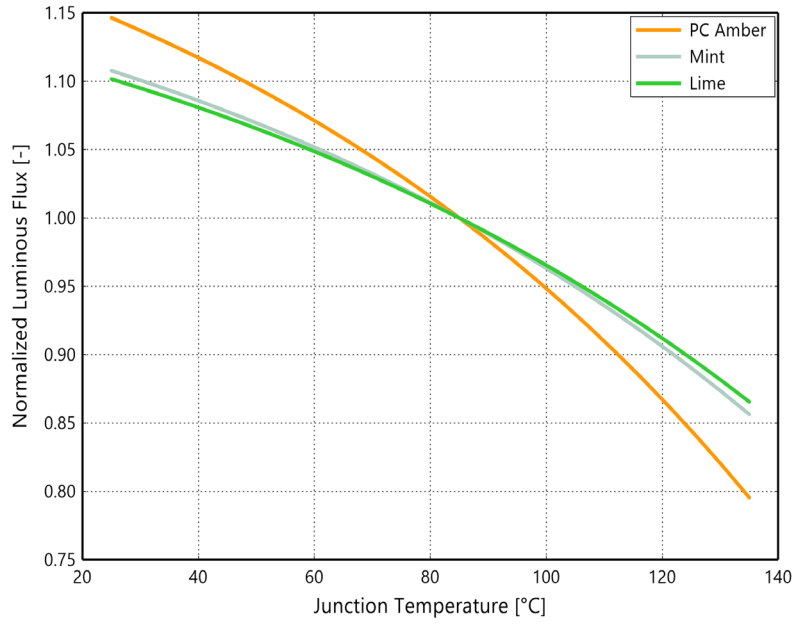

Figure 2c. Typical normalized luminous flux vs. junction temperature for LUXEON C ES PC Amber, Mint and Lime at 1000mA

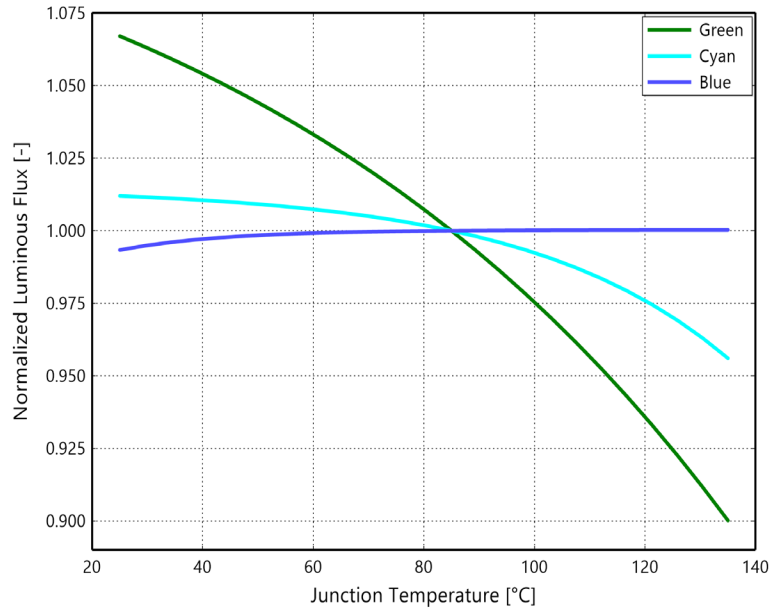

Figure 2d. Typical normalized luminous flux vs. junction temperature for LUXEON C ES Green, Cyan and Blue at 1000mA

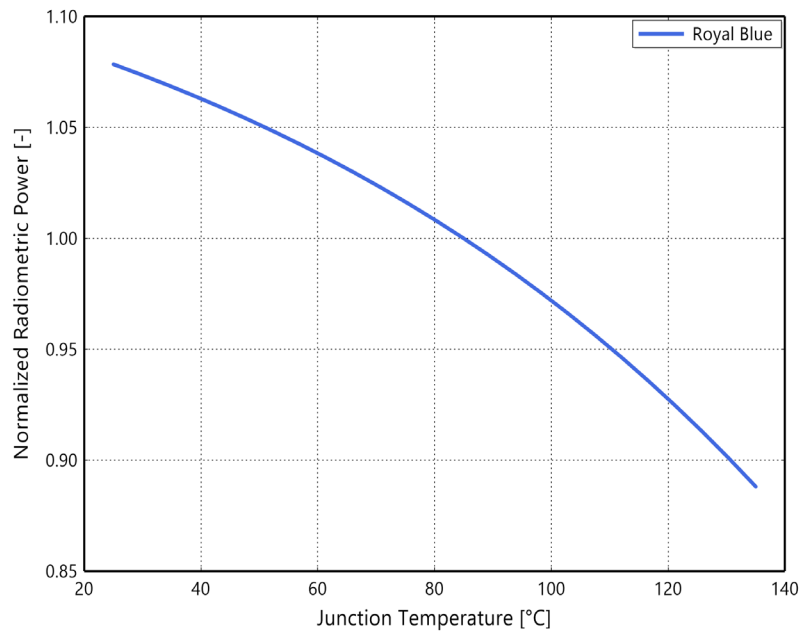

Figure 2e. Typical normalized radiometric power vs. junction temperature for LUXEON C ES Royal Blue at 1000mA

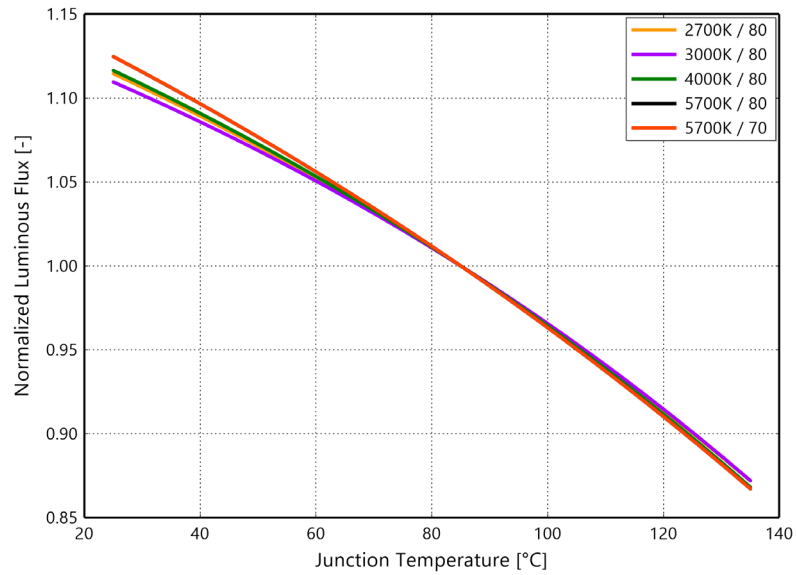

Figure 2f. Typical normalized luminous flux vs. junction temperature for LUXEON C ES White at 1000mA

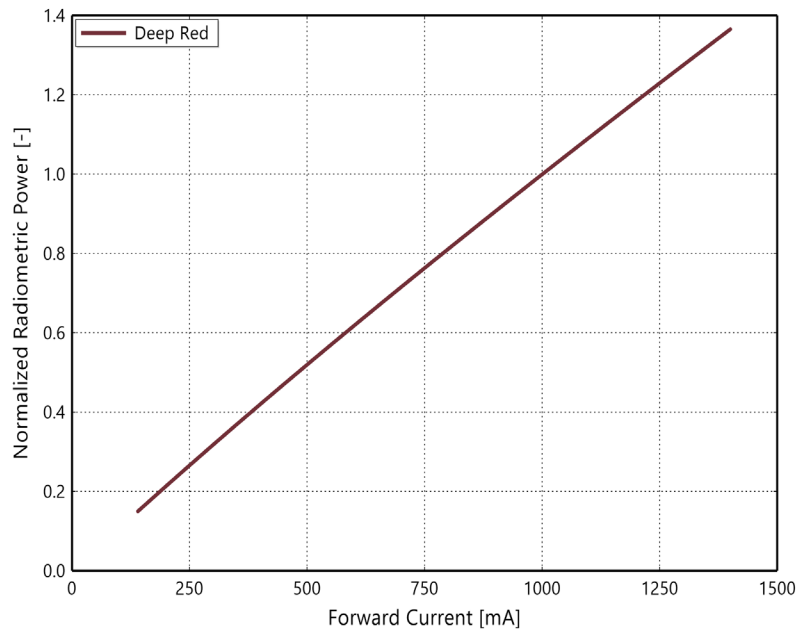

Figure 3a. Typical normalized radiometric power vs. forward current for LUXEON C ES Deep Red at $T_j=85^\circ\text{C}$

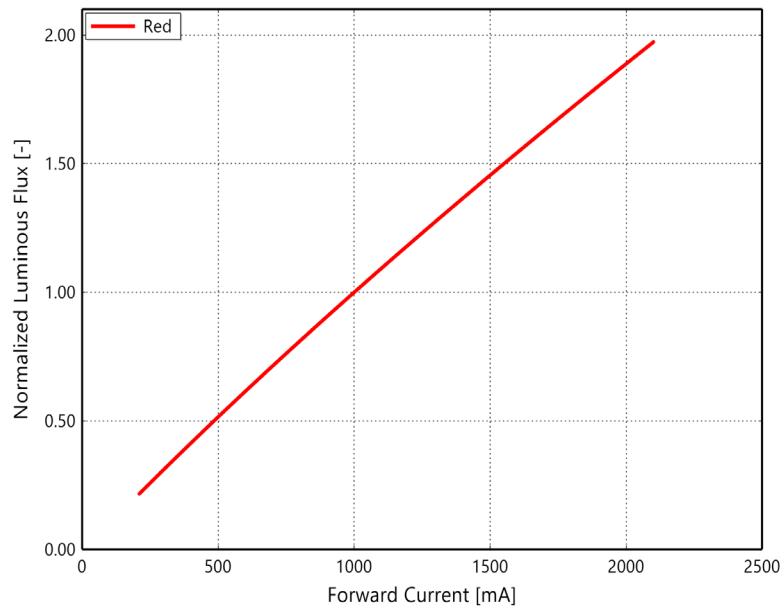

Figure 3b. Typical normalized luminous flux vs. forward current for LUXEON C ES Red at $T_j=85^\circ\text{C}$

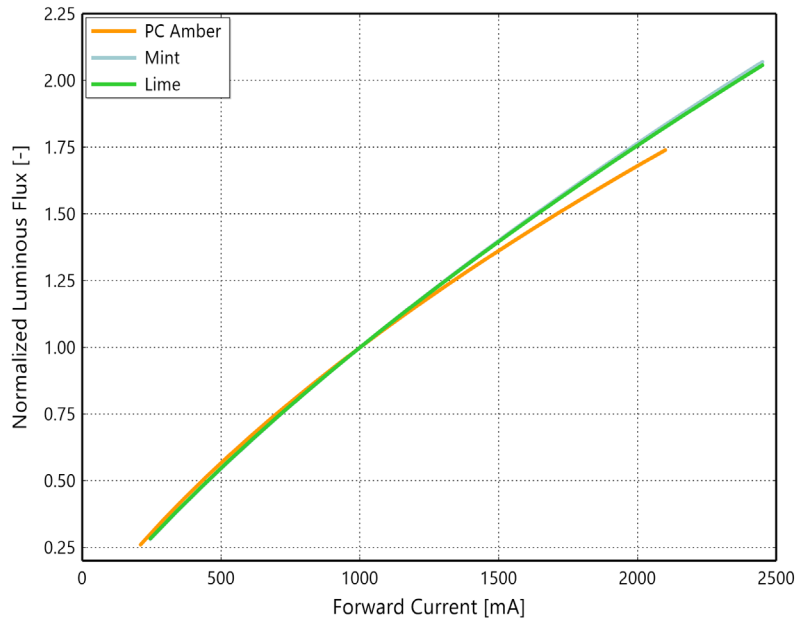

Figure 3c. Typical normalized luminous flux vs. forward current for LUXEON C ES PC Amber, Mint and Lime at $T_j=85^\circ\text{C}$

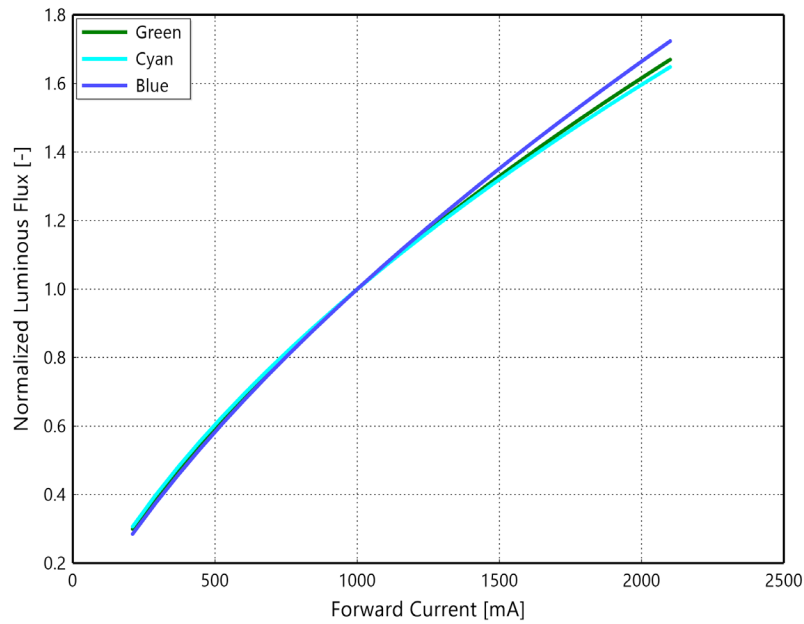

Figure 3d. Typical normalized luminous flux vs. forward current for LUXEON C ES Green, Cyan and Blue at $T_j=85^\circ\text{C}$

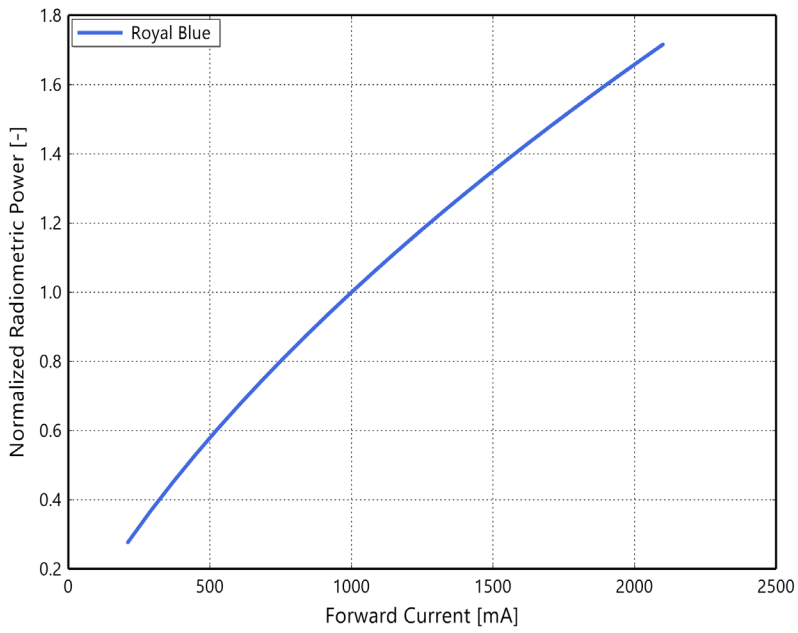

Figure 3e. Typical normalized radiometric power vs. forward current for LUXEON C ES Royal Blue at $T_j=85^\circ\text{C}$

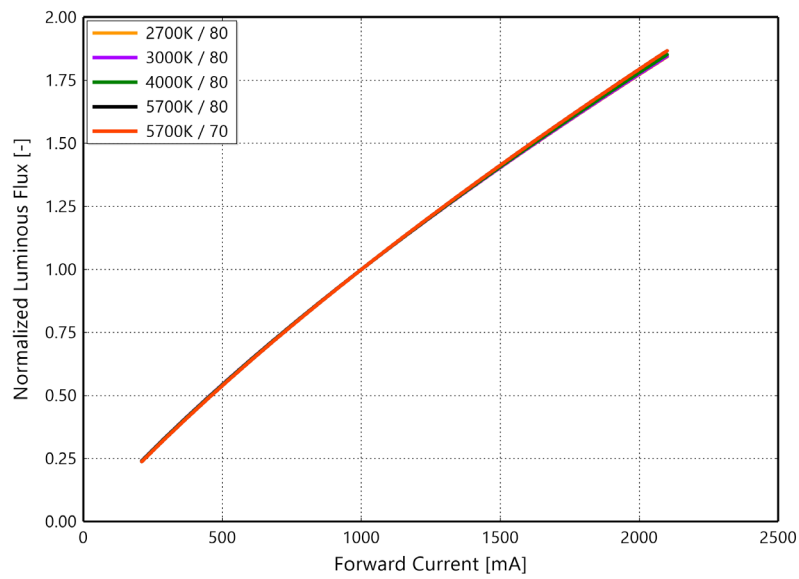

Figure 3f. Typical normalized luminous flux vs. forward current for LUXEON C ES White at $T_j=85^\circ\text{C}$

Forward Current Characteristics

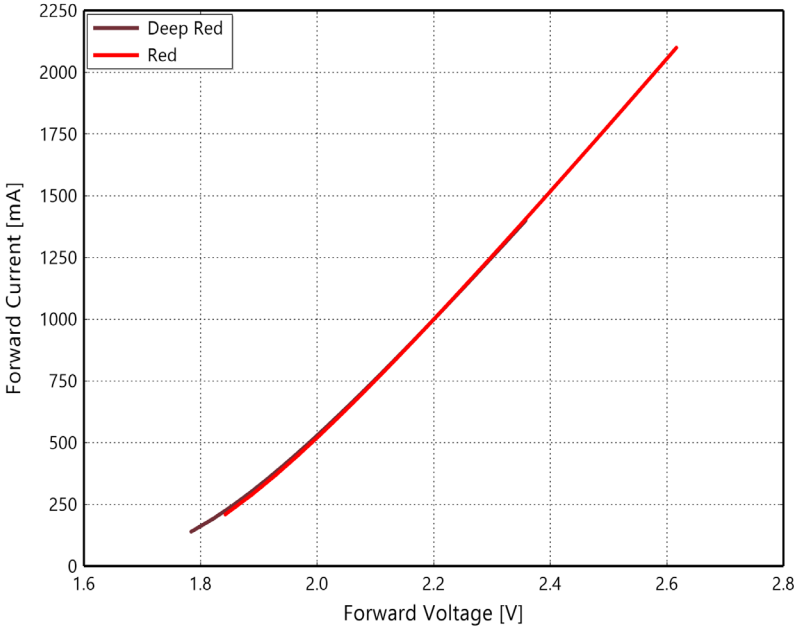

Figure 4a. Typical forward current vs. forward voltage for LUXEON C ES Deep Red and Red at $T_j=85^\circ\text{C}$

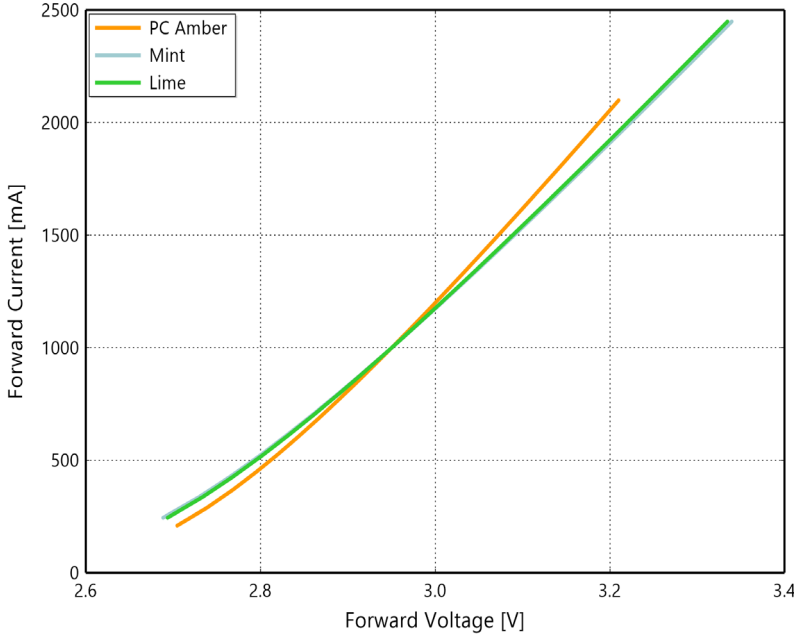

Figure 4b. Typical forward current vs. forward voltage for LUXEON C ES PC Amber, Mint and Lime at $T_j=85^\circ\text{C}$

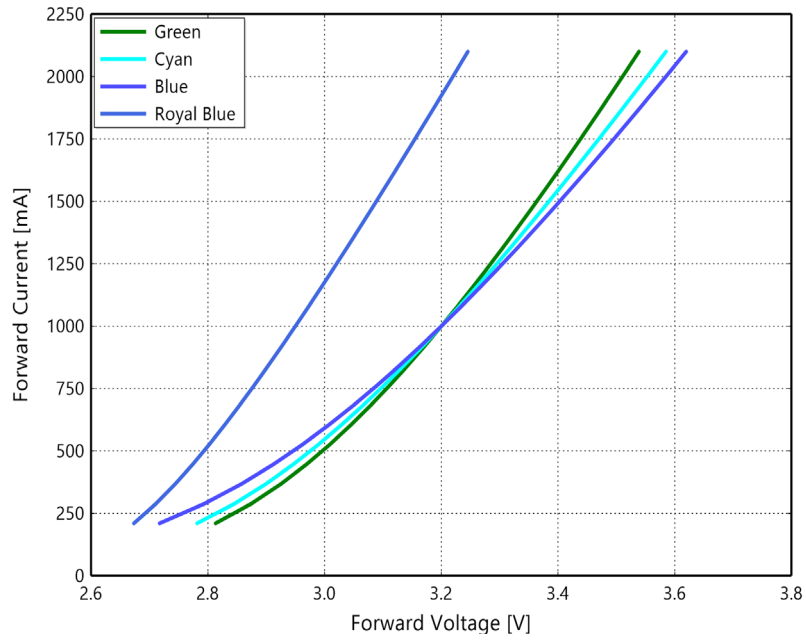

Figure 4c. Typical forward current vs. forward voltage for LUXEON C ES Green, Cyan, Blue and Royal Blue at $T_j=85^\circ\text{C}$

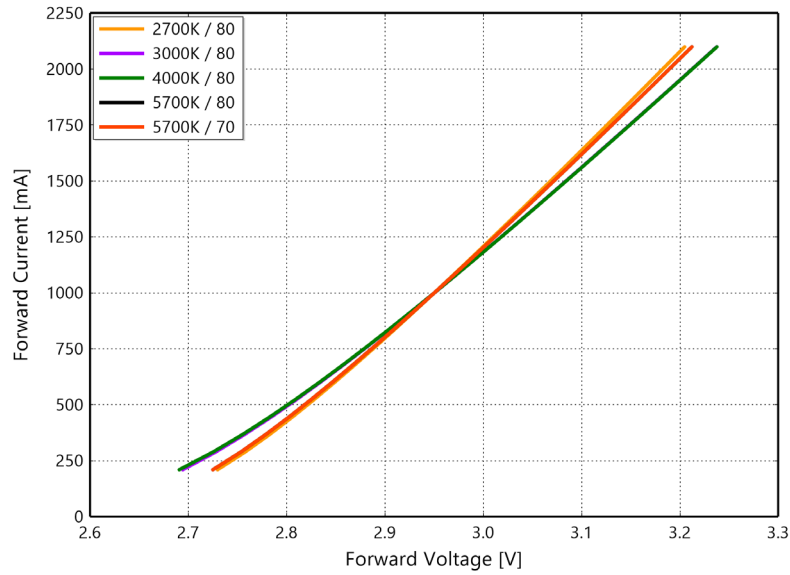

Figure 4d. Typical forward current vs. forward voltage for LUXEON C ES White at $T_j=85^\circ\text{C}$

Radiation Pattern Characteristics

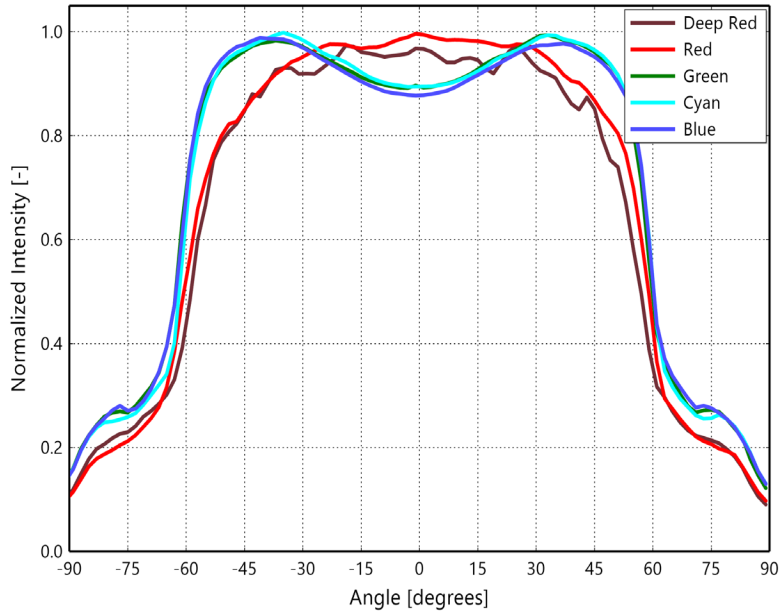

Figure 5a. Typical radiation pattern for LUXEON C ES Deep Red, Red, Green, Cyan and Blue at 1000mA, $T_j=85^{\circ}\text{C}$

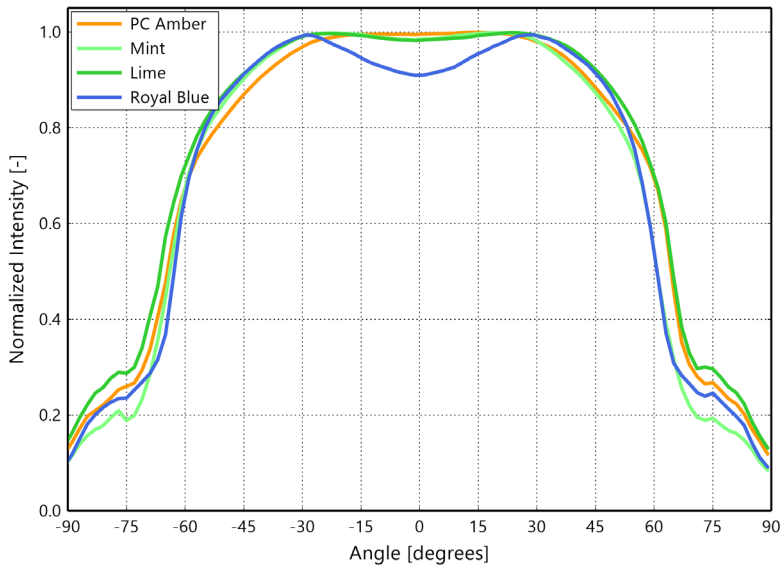

Figure 5b. Typical radiation pattern for LUXEON C ES PC Amber, Mint, Lime and Royal Blue at 1000mA, $T_j=85^{\circ}\text{C}$

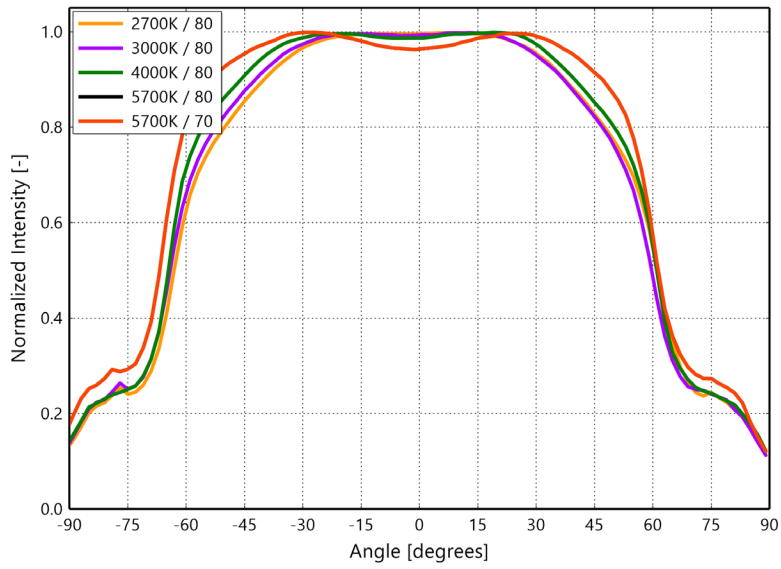

Figure 5c. Typical radiation pattern for LUXEON C ES White at 1000mA, $T_j=85^\circ\text{C}$

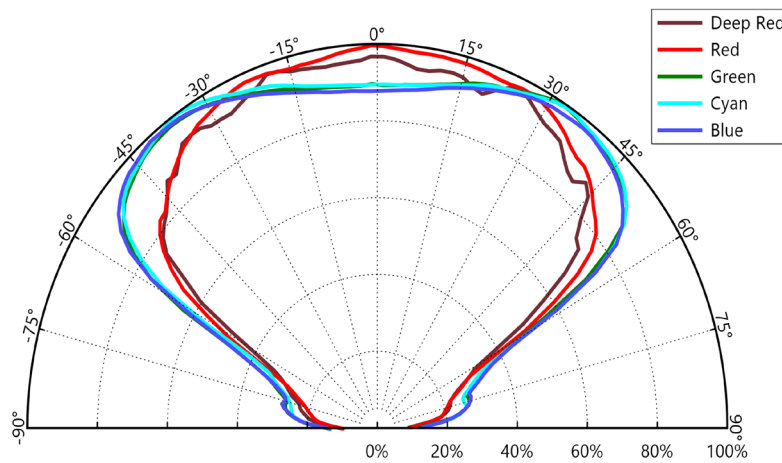

Figure 6a. Typical polar radiation pattern for LUXEON C ES Deep Red, Red, Green, Cyan and Blue at 1000mA, $T_j=85^\circ\text{C}$

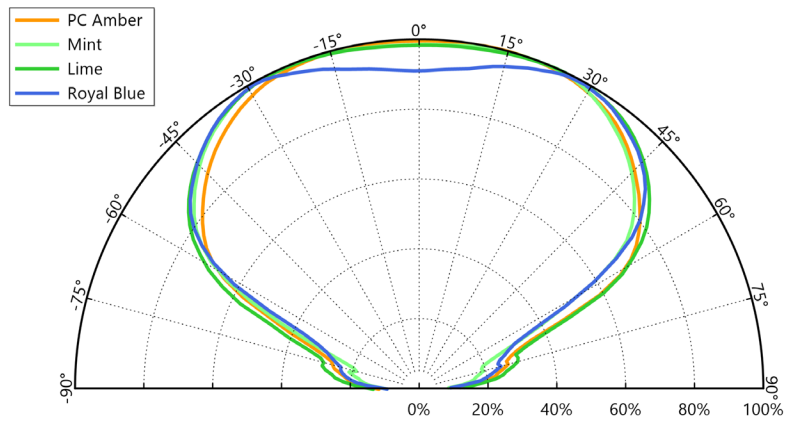

Figure 6b. Typical polar radiation pattern for LUXEON C ES PC Amber, Mint, Lime and Royal Blue at 1000mA, $T_j=85^\circ\text{C}$

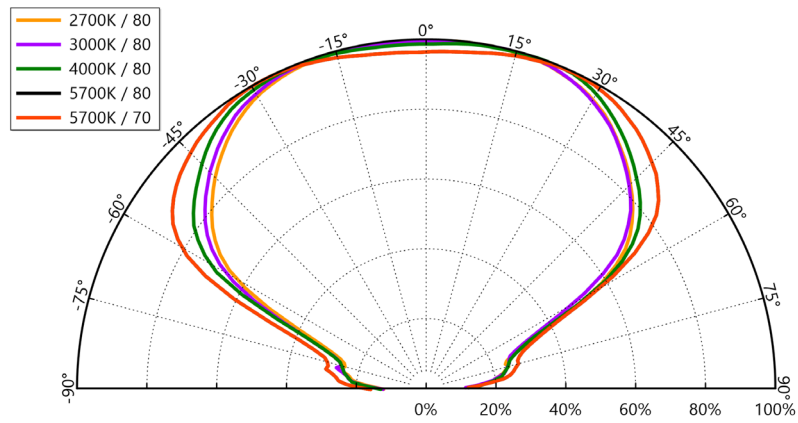

Figure 6c. Typical polar radiation pattern for LUXEON C ES White at 1000mA, $T_j=85^\circ\text{C}$

Product Bin and Labeling Definitions

Decoding Product Bin Labeling

In the manufacturing of semiconductor products, there are variations in performance around the average values given in the technical datasheet. For this reason, Lumileds bins LED components for luminous flux, radiometric power, color point, peak wavelength, dominant wavelength and forward voltage.

LUXEON C ES Color Line LEDs are labeled using a 4-digit alphanumeric CAT code following the format below:

A B C D

Where:

- A** – designates luminous flux bin or radiometric power bin (luminous flux bin example: A=90 to 95 lm, B= 95 to 100 lm; radiometric power bin example: Deep Red C=1040 to 1100mW, Royal Blue G=1320 to 1390mW)
- B C** – designates color bin, peak wavelength bin or dominant wavelength bin (peak wavelength bin example: Deep Red 10=655 to 665nm; dominant wavelength bin example: Red 40=624 to 634nm)
- D** – designates forward voltage bin (example: A=1.80 to 2.00V, B=2.00 to 2.20V)

Therefore, a LUXEON C ES Red LED with a lumen range of 110 to 115 lm, a dominant wavelength of 624 to 634nm and a forward voltage range of 2.20 to 2.40V has the following CAT code:

E 4 0 C

Luminous Flux Bins

Table 5 lists the standard photometric luminous flux bins for LUXEON C ES Color Line emitters. Although several bins are outlined, product availability in a particular bin varies by production run and by product performance. Not all bins are available in all CCTs.

Table 5. Luminous flux bin definitions for LUXEON C ES Color Line

BIN	LUMINOUS FLUX ^[1] (lm)	
	MINIMUM	MAXIMUM
A	90	95
B	95	100
C	100	105
D	105	110
E	110	115
F	115	120
G	120	130
H	130	140
J	140	150
K	150	160
L	160	180
M	180	200
N	200	220
P	220	240
Q	240	260
R	260	280
S	280	300
T	300	320
U	320	350
V	350	380
W	380	410
X	410	440
Y	440	480
Z	480	520
1	520	560
2	560	600

Notes for Table 5:

1. Lumileds maintains a tolerance of $\pm 6.5\%$ on luminous flux measurements.

Radiometric Power Bins

Table 6. Radiometric power bin definitions for LUXEON C ES Deep Red and Royal Blue

COLOR	BIN	RADIOMETRIC POWER ⁽¹⁾ (mW)	
		MINIMUM	MAXIMUM
Deep Red	A	900	970
	B	970	1040
	C	1040	1110
	D	1110	1180
Royal Blue	F	1230	1310
	G	1310	1390
	H	1390	1460
	J	1460	1530
	K	1530	1600
	L	1600	1670

Notes for Table 6:
 1. Lumileds maintains a tolerance of ±6.5% on radiometric power measurements.

Color Bin Definitions

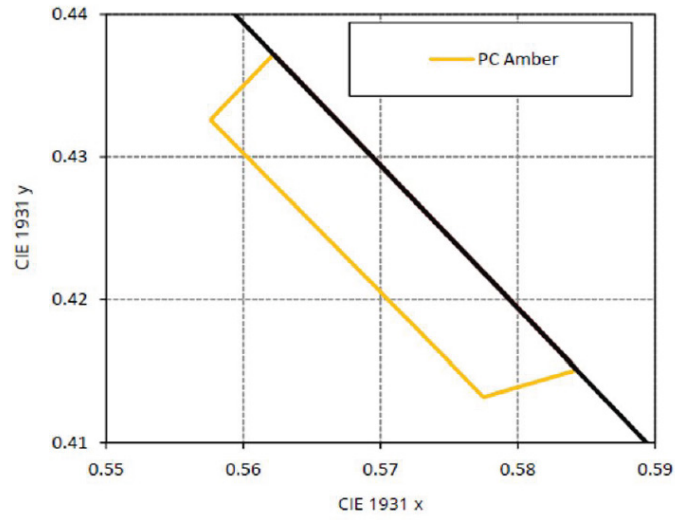

Figure 7. Color bin structure for LUXEON C ES PC Amber for Table 7

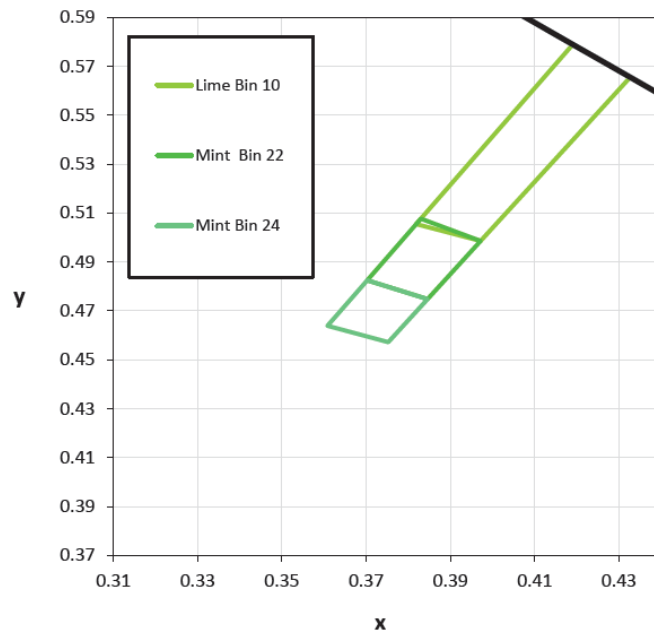

Figure 8. Color bin structure for LUXEON C ES Mint and Lime for Table 7

Table 7. Color bin definitions for LUXEON C ES PC Amber, Mint and Lime

COLOR	PART NUMBER	BIN	x	y
PC Amber	L1C2-PCA1000000000	20	0.5622	0.4372
			0.5576	0.4326
			0.5775	0.4132
			0.5843	0.4151
Mint	L1C2-MNT1000000000	22	0.3972	0.4986
			0.3830	0.5077
			0.3703	0.4825
		24	0.3846	0.4749
			0.3846	0.4749
			0.3703	0.4825
Lime	L1C2-LME1000000000	10	0.3608	0.4639
			0.3752	0.4572
			0.3819	0.5055
			0.4191	0.5790
			0.4327	0.5655
			0.3972	0.4986

Notes for Table 7:

1. Lumileds maintains a tolerance of ± 0.005 on x and y color coordinates measurements.

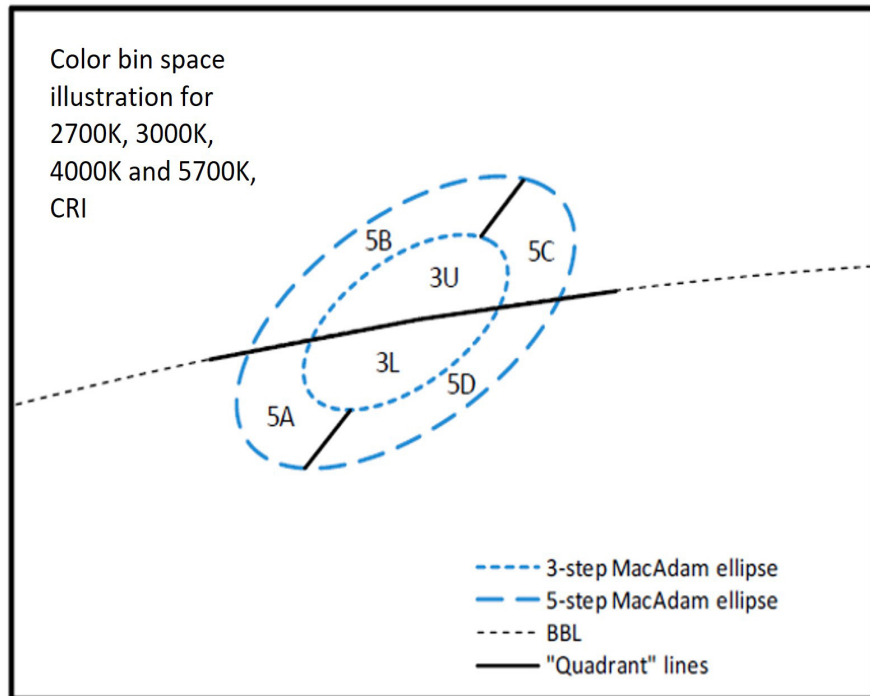

Figure 9. Color bin structure for LUXEON C ES Color Line

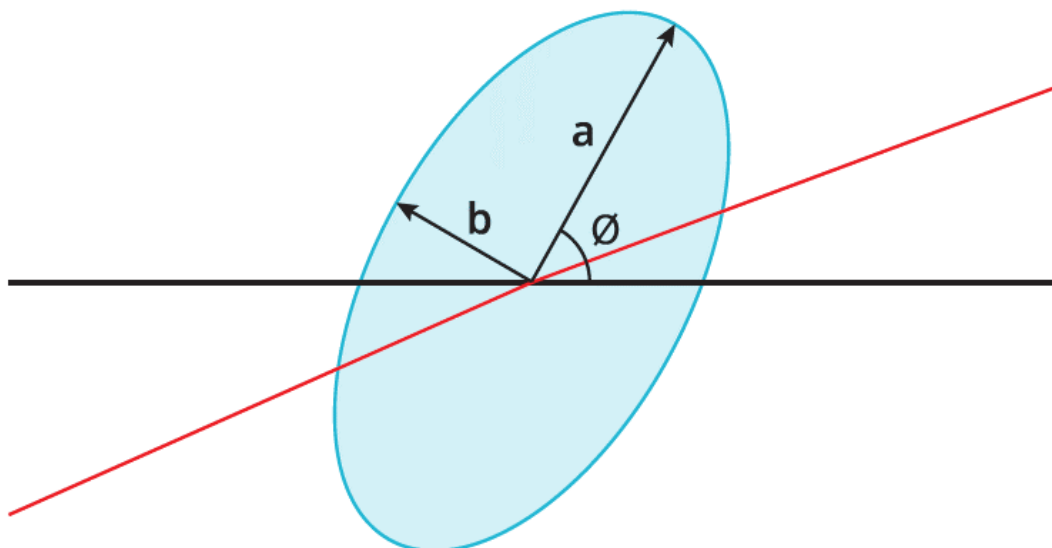

Figure 10. 3- and 5-step MacAdam ellipse illustration for Tables 8a and 8b

Table 8a. 3- and 5-step MacAdam ellipse color bin definitions for LUXEON C ES White at 1000mA, $T_j = 85^\circ\text{C}$

NOMINAL CCT	COLOR SPACE	CENTER POINT (cx, cy)	MAJOR AXIS, a	MINOR AXIS, b	ELLIPSE ROTATION ANGLE, θ
2700K	Single 3-step MacAdam ellipse	(0.4578, 0.4101)	0.00810	0.00420	53.7°
3000K	Single 3-step MacAdam ellipse	(0.4338, 0.4030)	0.00834	0.00408	53.2°
4000K	Single 3-step MacAdam ellipse	(0.3818, 0.3797)	0.00939	0.00402	53.7°
5700K	Single 3-step MacAdam ellipse	(0.3287, 0.3417)	0.00746	0.00320	59.09°
2700K	Single 5-step MacAdam ellipse	(0.4578, 0.4101)	0.01350	0.00700	53.7°
3000K	Single 5-step MacAdam ellipse	(0.4338, 0.4030)	0.01390	0.00680	53.2°
4000K	Single 5-step MacAdam ellipse	(0.3818, 0.3797)	0.01565	0.00670	53.7°
5700K	Single 5-step MacAdam ellipse	(0.3287, 0.3417)	0.01243	0.00533	59.1°

Notes for Table 8a:

1. Lumileds maintains a tolerance of ± 0.005 on x and y coordinates in the CIE 1931 color space.

Table 8b. MacAdam ellipse color bin definitions for LUXEON C ES Color Line

NOMINAL CCT	SDCM
30	Single 3-step MacAdam ellipse (CCTs 5000K and above)
3U	Single 3-step MacAdam ellipse (80 CRI and CCTs 4000K and below)
3L	Single 3-step MacAdam ellipse (80 CRI and CCTs 4000K and below)
50	Single 5-step MacAdam ellipse (70CRI)
5A	Single 5-step MacAdam ellipse (80CRI)
5B	Single 5-step MacAdam ellipse (80CRI)
5C	Single 5-step MacAdam ellipse (80CRI)
5D	Single 5-step MacAdam ellipse (80CRI)

Peak Wavelength Bins

Table 9. Peak wavelength bin definitions for LUXEON C ES Deep Red and Royal Blue

COLOR	PART NUMBER	BIN	PEAK WAVELENGTH ⁽¹⁾ (nm)	
			MINIMUM	MAXIMUM
Deep Red	L1C2-DRD1000000000	10	655	665
		20	665	675
Royal Blue	L1C2-RYL1000000000	30	440	445
		40	445	450
		50	450	455
		60	455	460

Notes for Table 9:

1. Lumileds maintains a tolerance of ± 2.0 nm on peak wavelength measurements.

Dominant Wavelength Bins

Table 10. Dominant wavelength bin definitions for LUXEON C ES Red, Green, Cyan and Blue at 1000mA, T_j=85°C

COLOR	PART NUMBER	BIN	DOMINANT WAVELENGTH ⁽¹⁾ (nm)	
			MINIMUM	MAXIMUM
Red	L1C2-RED1000000000	40	624.0	634.0
Green	L1C2-GRN1000000000	10	520.0	525.0
		20	525.0	530.0
		30	530.0	535.0
		40	535.0	540.0
Cyan	L1C2-CYN1000000000	10	490.0	496.0
		20	496.0	500.0
		30	500.0	505.0
		40	505.0	510.0
Blue	L1C2-BLU1000000000	20	465.0	470.0
		30	470.0	475.0
		40	475.0	480.0
		50	480.0	485.0

Notes for Table 10:

1. Lumileds maintains a tolerance of ± 0.5 nm on dominant wavelength measurements.

Forward Voltage Bins

Table 11. Forward voltage bin definitions for LUXEON C ES Color Line

BIN	FORWARD VOLTAGE ⁽¹⁾ (V _F)	
	MINIMUM	MAXIMUM
A	1.80	2.00
B	2.00	2.20
C	2.20	2.40
D	2.40	2.60
E	2.60	2.80
F	2.80	3.00
G	3.00	3.20
H	3.20	3.40
J	3.40	3.60

Notes for Table 11:

1. Lumileds maintains a tolerance of ±0.06V on forward voltage measurements.

Mechanical Dimensions

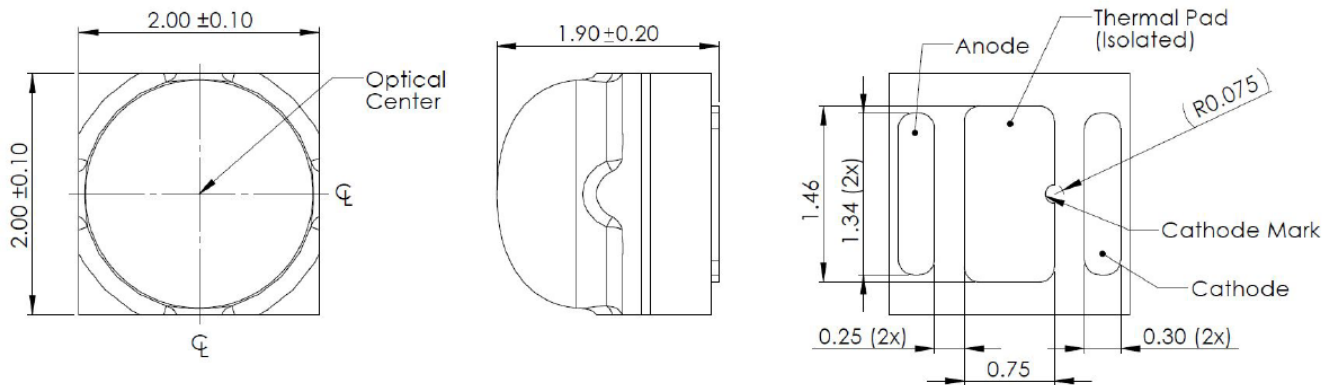

Figure 11. Mechanical dimensions for LUXEON C ES Color Line

Notes for Figure 11:

1. Drawings are not to scale.
2. All dimensions are in millimeters.

Reflow Soldering Guidelines

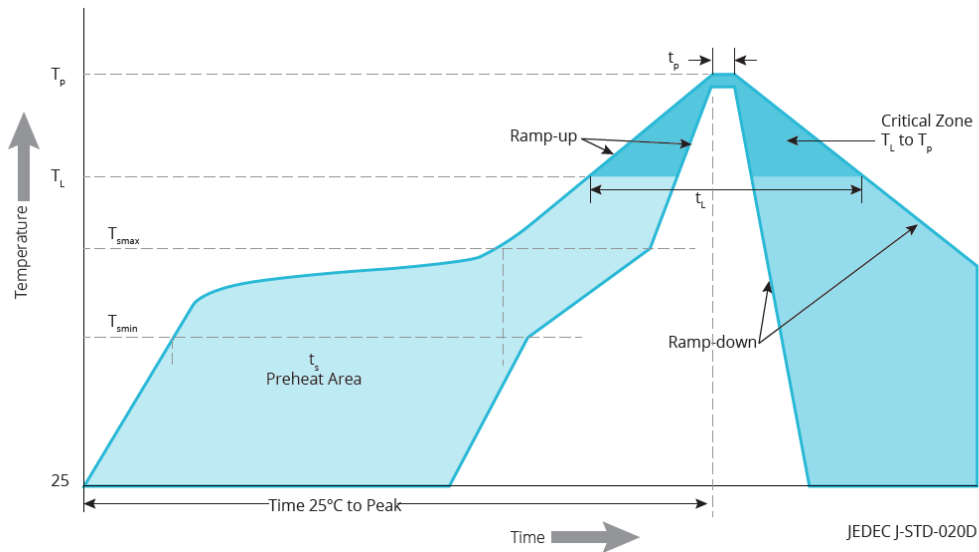

Figure 12. Visualization of the acceptable reflow temperature profile as specified in Table 12

Table 12. Reflow profile characteristics for LUXEON C ES Color Line

PROFILE FEATURE	LEAD-FREE ASSEMBLY
Preheat Minimum Temperature (T_{smin})	150°C
Preheat Maximum Temperature (T_{smax})	200°C
Preheat Time (t_{smin} to t_{smax})	60 to 120 seconds
Ramp-Up Rate (T_L to T_p)	3°C / second maximum
Liquidus Temperature (T_L)	217°C
Time Maintained Above Temperature T_L (t_t)	60 to 150 seconds
Peak / Classification Temperature (T_p)	260°C
Time Within 5°C of Actual Temperature (t_p)	20 to 40 seconds
Ramp-Down Rate (T_p to T_L)	6°C / second maximum
Time 25°C to Peak Temperature	8 minutes maximum

JEDEC Moisture Sensitivity

Table 12. Moisture sensitivity levels for LUXEON C ES Color Line

LEVEL	FLOOR LIFE		SOAK REQUIREMENTS STANDARD	
	TIME	CONDITIONS	TIME	CONDITIONS
1	Unlimited	≤30°C / 85% RH	168 Hours +5 / -0	85°C / 85% RH

Solder Pad Design

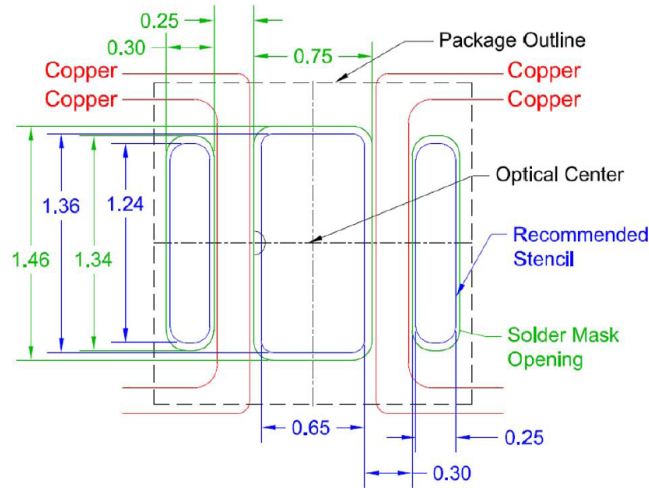

Figure 13. Recommended PCB solder pad layout for LUXEON C ES Color Line

Notes for Figure 13:

- 1. Drawings are not to scale.
- 2. All dimensions are in millimeters.
- 3. The drawing above shows the recommended solder pad layout on Printed Circuit Board (PCB).

Packaging Information

Pocket Tape Dimensions

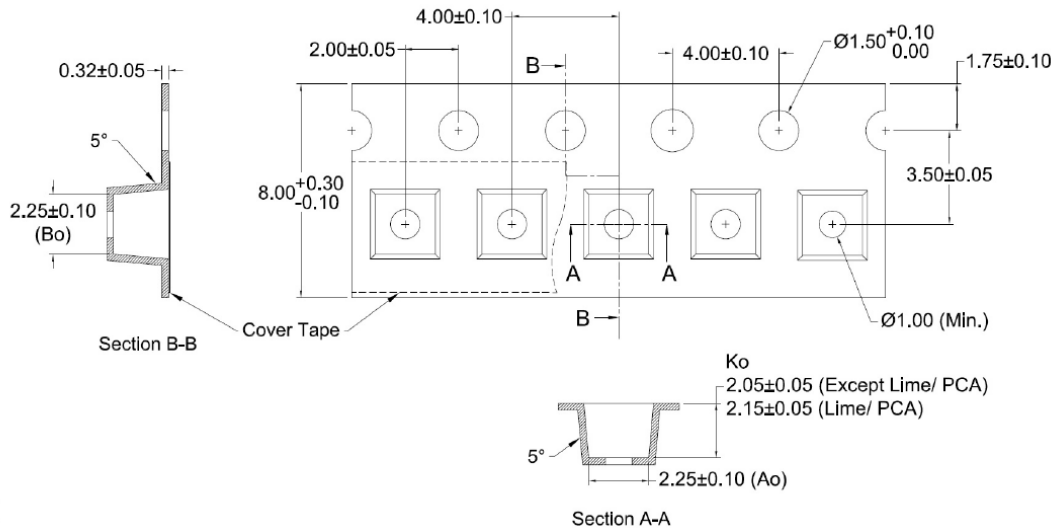

Figure 14. Pocket Tape dimensions for LUXEON C ES Color Line

Notes for Figure 14:

- 1. Drawings are not to scale.
- 2. All dimensions are in millimeters.

Reel Dimensions

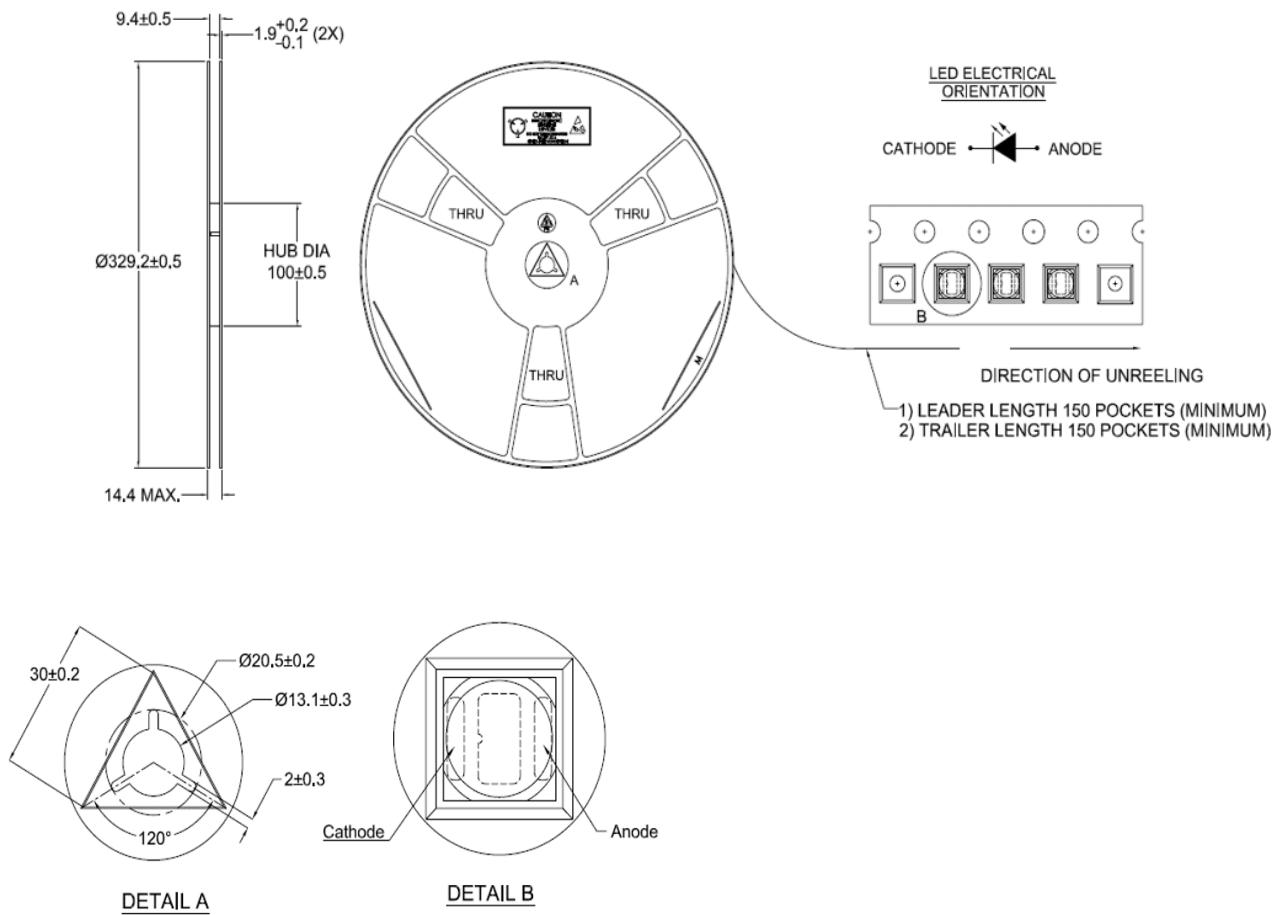

Figure 15. Reel dimensions for LUXEON C ES Color Line

Notes for Figure 15:

1. Drawings are not to scale.
2. All dimensions are in millimeters.
3. Maximum 1,000 pieces per reel.

About Lumileds

Lumileds is a global leader in LED and microLED technology, innovation, and solutions for the automotive, display, illumination, mobile, and other markets where light sources are essential. Our approximately 3,500 employees operate in over 15 countries and partner with our customers to deliver never before possible solutions for lighting, safety, and well-being.

To learn more about our lighting solutions, visit lumileds.com.



©2026 Lumileds Holding B.V. All rights reserved.
LUXEON is a registered trademark of the Lumileds Holding B.V. in the United States and other countries.

lumileds.com

Neither Lumileds Holding B.V. nor its affiliates shall be liable for any kind of loss of data or any other damages, direct, indirect or consequential, resulting from the use of the provided information and data. Although Lumileds Holding B.V. and/or its affiliates have attempted to provide the most accurate information and data, the materials and services information and data are provided "as is," and neither Lumileds Holding B.V. nor its affiliates warrants or guarantees the contents and correctness of the provided information and data. Lumileds Holding B.V. and its affiliates reserve the right to make changes without notice. You as user agree to this disclaimer and user agreement with the download or use of the provided materials, information and data. A listing of Lumileds product/patent coverage may be accessed at lumileds.com/patents.