

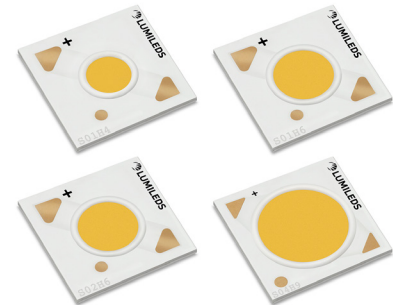

LUXEON CX Plus CoB – High Density

Higher lumen density with industry standard footprint

LUXEON CX Plus CoB – High Density LEDs focus on delivering the highest flux, up to 5600 lumens, with an industry standard footprint of 13.35mm x 13.35mm and Light Emitting Surfaces of 4.5mm, 6mm, and 9mm. The combination of superior performance and industry standard footprint allows for an immediate and effortless upgrade to higher flux luminaire designs within existing ecosystems. LUXEON CX Plus CoB – High Density is available in 2- and 3-step MacAdam ellipse color definition, enabling color consistency.



FEATURES AND BENEFITS

Industry's smallest Light Emitting Surfaces (LES) for highest lumen densities

An immediate, effortless upgrade to existing designs using legacy CoBs with a square footprint

2- and 3-step MacAdam ellipse ensuring color consistency from luminaire to luminaire

PRIMARY APPLICATIONS

Spotlights

Track Lights

Downlights

Table of Contents

General Product Information	2
Product Test Conditions	2
Part Number Nomenclature	2
Lumen Maintenance	2
Environmental Compliance	2
Performance Characteristics	3
Product Selection Guide	3
Optical Characteristics	4
Electrical and Thermal Characteristics	4
Absolute Maximum Ratings	4
Characteristic Curves	5
Spectral Power Distribution Characteristics	5
Light Output Characteristics	6
Forward Current Characteristics	7
Radiation Pattern Characteristics	8
Color Bin Definitions	9
Mechanical Dimensions	10
Packaging and Labeling Information	11
Tray Dimensions	11
Inner Box	12
Outer Box	13

General Product Information

Product Test Conditions

LUXEON CX Plus CoB – High Density LEDs are tested and binned with a DC drive current specified below at a junction temperature, T_j , of 85°C:

175mA	–	LUXEON CX Plus CoB – HD S01H4
175mA	–	LUXEON CX Plus CoB – HD S01H6
350mA	–	LUXEON CX Plus CoB – HD S02H6
700mA	–	LUXEON CX Plus CoB – HD S04H9

Part Number Nomenclature

Part numbers for LUXEON CX Plus CoB – High Density follow the convention below:

L 2 C 4 – **A A B B C D D D E F F G G**

Where:

- A A** – designates nominal CCT (27=2700K, 30=3000K, 35=3500K, 40=4000K, 50=5000K)
- B B** – designates minimum CRI (80=80CRI, 90=90CRI)
- C** – designates SDCM (2=2-step MacAdam ellipse, 3=3-step MacAdam ellipse)
- D D D** – designates product configuration (S01, S02, S04)
- E** – designates options for product specification
- F F** – designates light emitting surface (LES) size (04=4.5mm, H6=6mm, 06=6mm, 09=9mm)
- G G** – designates options for product specification

Therefore, the following part number is used for a LUXEON CX Plus CoB – High Density, 3000K 90CRI, 3-step MacAdam ellipse, S01H4, 4.5mm LES:

L 2 C 4 – **3 0 9 0 3 S 0 1 F 0 4 0 0**

Lumen Maintenance

Please contact your local Sales Representative or Lumileds Technical Solutions Manager for more information about the long-term performance of this product.

Environmental Compliance

Lumileds LLC is committed to providing environmentally friendly products to the solid-state lighting market. LUXEON CX Plus CoB – High Density is compliant to the European Union directives on the restriction of hazardous substances in electronic equipment, namely the RoHS Directive 2011/65/EU and REACH Regulation (EC) 1907/2006. Lumileds LLC will not intentionally add the following restricted materials to its products: lead, mercury, cadmium, hexavalent chromium, polybrominated biphenyls (PBB) or polybrominated diphenyl ethers (PBDE).

Performance Characteristics

Product Selection Guide

Table 1. Product performance of LUXEON CX Plus CoB – High Density at specified test current, $T_j=85^\circ\text{C}$.

PRODUCT	NOMINAL CCT	MINIMUM CRI ^[1, 2, 3]	LUMINOUS FLUX ^[1] (lm)		TYPICAL LUMINOUS EFFICACY (lm/W)	TEST CURRENT (mA)	LES ^[5] (mm)	ENERGY EFFICIENCY CLASS ^[7]	PART NUMBER ^[6]
			MINIMUM	TYPICAL ^[4]					
LUXEON CX Plus CoB – HD S01H4	2700K	80	667	725	110	175	4.5	F	L2C4-2780xS01F0400
	3000K	80	713	775	118	175	4.5	F	L2C4-3080xS01F0400
	3500K	80	727	790	120	175	4.5	E	L2C4-3580xS01F0400
	4000K	80	750	815	124	175	4.5	E	L2C4-4080xS01F0400
	5000K	80	750	815	124	175	4.5	E	L2C4-5080xS01F0400
	2700K	90	580	630	96	175	4.5	F	L2C4-2790xS01F0400
	3000K	90	603	655	100	175	4.5	F	L2C4-3090xS01F0400
	3500K	90	639	695	106	175	4.5	F	L2C4-3590xS01F0400
	4000K	90	653	710	108	175	4.5	F	L2C4-4090xS01F0400
	5000K	90	644	700	107	175	4.5	F	L2C4-5090xS01F0400
LUXEON CX Plus CoB – HD S01H6	2700K	80	699	760	116	175	6.0	F	L2C4-2780xS01FH600
	3000K	80	741	805	123	175	6.0	E	L2C4-3080xS01FH600
	3500K	80	750	815	124	175	6.0	E	L2C4-3580xS01FH600
	4000K	80	759	825	126	175	6.0	E	L2C4-4080xS01FH600
	5000K	80	759	825	126	175	6.0	E	L2C4-5080xS01FH600
	2700K	90	593	645	98	175	6.0	F	L2C4-2790xS01FH600
	3000K	90	621	675	103	175	6.0	F	L2C4-3090xS01FH600
	3500K	90	649	705	107	175	6.0	F	L2C4-3590xS01FH600
	4000K	90	672	730	111	175	6.0	F	L2C4-4090xS01FH600
	5000K	90	667	725	110	175	6.0	F	L2C4-5090xS01FH600
LUXEON CX Plus CoB – HD S02H6	2700K	80	1352	1470	112	350	6.0	F	L2C4-2780xS02F0600
	3000K	80	1426	1550	118	350	6.0	F	L2C4-3080xS02F0600
	3500K	80	1454	1580	120	350	6.0	E	L2C4-3580xS02F0600
	4000K	80	1518	1650	126	350	6.0	E	L2C4-4080xS02F0600
	5000K	80	1518	1650	126	350	6.0	E	L2C4-5080xS02F0600
	2700K	90	1159	1260	96	350	6.0	Note 8	L2C4-2790xS02F0600
	3000K	90	1228	1335	102	350	6.0	F	L2C4-3090xS02F0600
	3500K	90	1297	1410	107	350	6.0	F	L2C4-3590xS02F0600
	4000K	90	1334	1450	110	350	6.0	F	L2C4-4090xS02F0600
	5000K	90	1320	1435	109	350	6.0	F	L2C4-5090xS02F0600
LUXEON CX Plus CoB – HD S04H9	2700K	80	2742	2980	114	700	9.0	F	L2C4-2780xS04F0900
	3000K	80	2926	3180	121	700	9.0	E	L2C4-3080xS04F0900
	3500K	80	2990	3250	124	700	9.0	E	L2C4-3580xS04F0900
	4000K	80	3054	3320	126	700	9.0	E	L2C4-4080xS04F0900
	5000K	80	3054	3320	126	700	9.0	E	L2C4-5080xS04F0900
	2700K	90	2282	2480	94	700	9.0	Note 8	L2C4-2790xS04F0900
	3000K	90	2429	2640	101	700	9.0	Note 8	L2C4-3090xS04F0900
	3500K	90	2576	2800	107	700	9.0	F	L2C4-3590xS04F0900
	4000K	90	2659	2890	110	700	9.0	F	L2C4-4090xS04F0900
	5000K	90	2631	2860	109	700	9.0	F	L2C4-5090xS04F0900

Notes for Table 1:

1. Lumileds maintains a tolerance of ± 2 on CRI and $\pm 6.5\%$ on luminous flux measurements.
2. Typical CRI is approximately 2 points higher than the minimum CRI specified, but this is not guaranteed.
3. R9 value of 90CRI products is >50 and for 80CRI products it is >0 .
4. Maximum flux is 10% above typical flux.
5. Light Emitting Surface (LES) is the inner diameter (phosphor area) inside the dam.
6. Part number "x" designates SDCM (2=2-step MacAdam ellipse, 3=3-step MacAdam ellipse).
7. Energy efficiency class as specified in Commission Delegated Regulation (EU) 2019/2015. The available range of energy efficiency classes is A-G.
8. Exception: Not available in EU or UK.

Optical Characteristics

Table 2. Optical characteristics for LUXEON CX Plus CoB – High Density at specified test current, $T_j=85^\circ\text{C}$.

PART NUMBER	TYPICAL TOTAL INCLUDED ANGLE ^[1]	TYPICAL VIEWING ANGLE ^[2]
L2C4-xxxxxS0xFxx00	135°	115°

Notes for Table 2:

- Total angle at which 90% of total luminous flux is captured.
- Viewing angle is the off axis angle from the LED centerline where the luminous intensity is ½ of the peak value.

Electrical and Thermal Characteristics

Table 3. Electrical and thermal characteristics for LUXEON CX Plus CoB – High Density at specified test current, $T_j=85^\circ\text{C}$.

PART NUMBER	FORWARD VOLTAGE ^[1] (V_f)			TYPICAL TEMPERATURE COEFFICIENT OF FORWARD VOLTAGE ^[2] (mV/°C)	TYPICAL THERMAL RESISTANCE—JUNCTION TO CASE ^[3] (°C/W)
	MINIMUM	TYPICAL	MAXIMUM		
L2C4-xxxxxS01F0400	34.0	37.5	39.0	-16	1.80
L2C4-xxxxxS01FH600	34.0	37.5	39.0	-16	1.70
L2C4-xxxxxS02F0600	34.0	37.5	39.0	-16	0.80
L2C4-xxxxxS04F0900	34.0	37.5	39.0	-16	0.55

Notes for Table 3:

- Lumileds maintains a tolerance of $\pm 2\%$ on forward voltage measurements.
- Measured between 25°C and 85°C.
- Thermal resistance is measured between junction and the bottom of the LUXEON CoB substrate.

Absolute Maximum Ratings

Table 4. Absolute maximum ratings for LUXEON CX Plus CoB – High Density.

PARAMETER	MAXIMUM PERFORMANCE
DC Forward Current ^[1,2]	2x test current (Refer to derating curve below)
LED Junction Temperature ^[1] (DC & Pulse)	150°C
ESD Sensitivity (ANSI/ESDA/JEDEC JS-001-2012)	Class 3B
Operating Case Temperature ^[1]	-40°C to 125°C
LED Storage Temperature	-40°C to 125°C
Allowable Reflow Cycles ^[3]	—
Reverse Voltage ($V_{reverse}$)	LUXEON LEDs are not designed to be driven in reverse bias

Notes for Table 4:

- Case temperature is the temperature measured at the T_c point on the substrate. Proper current derating must be observed to maintain the junction temperature below the maximum allowable junction temperature.
- Residual periodic variations due to power conversion from alternating current (AC) to direct current (DC), also called “ripple,” are acceptable if the following conditions are met:
 - The frequency of the ripple current is 100Hz or higher
 - The average current for each cycle does not exceed the maximum allowable DC forward current
 - The maximum amplitude of the ripple does not exceed 20% of the maximum allowable DC forward current.

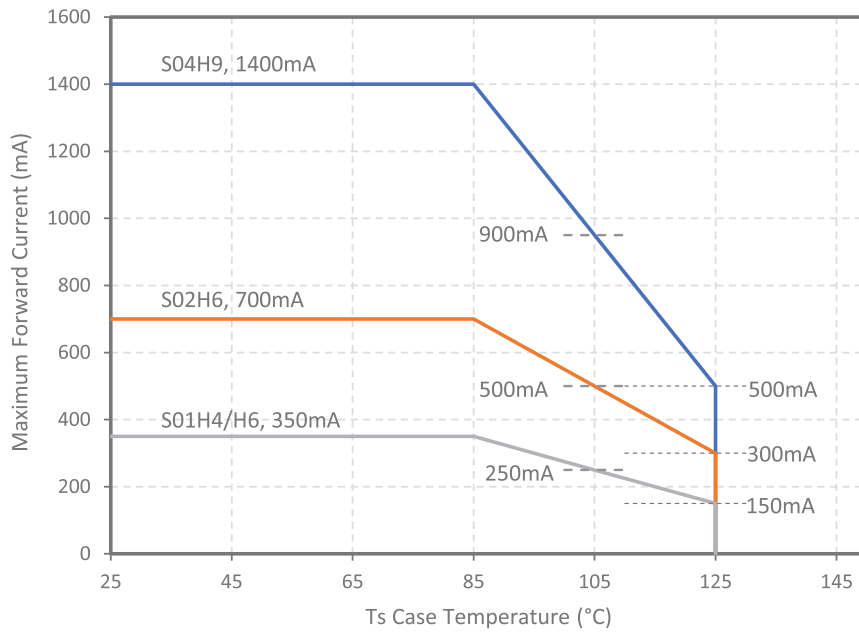

Figure 1. Maximum forward current vs. case temperature for LUXEON CX Plus CoB – High Density at specified test current.

Characteristic Curves

Spectral Power Distribution Characteristics

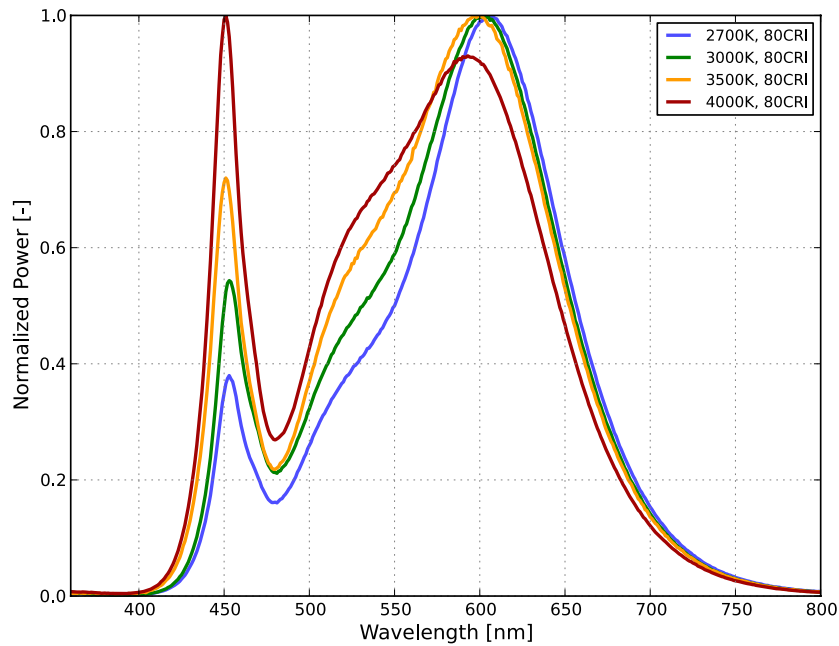

Figure 2a. Typical normalized power vs. wavelength for LUXEON CX Plus CoB – High Density 80CRI at specified test current, $T_j=85^\circ\text{C}$.

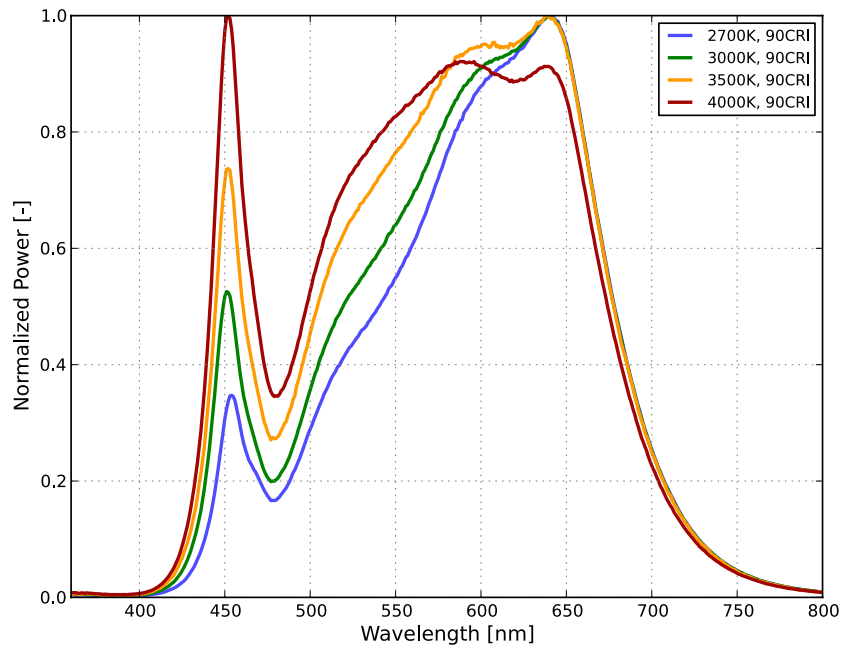

Figure 2b. Typical normalized power vs. wavelength for LUXEON CX Plus CoB – High Density 90CRI at specified test current, $T_j=85^\circ\text{C}$.

Light Output Characteristics

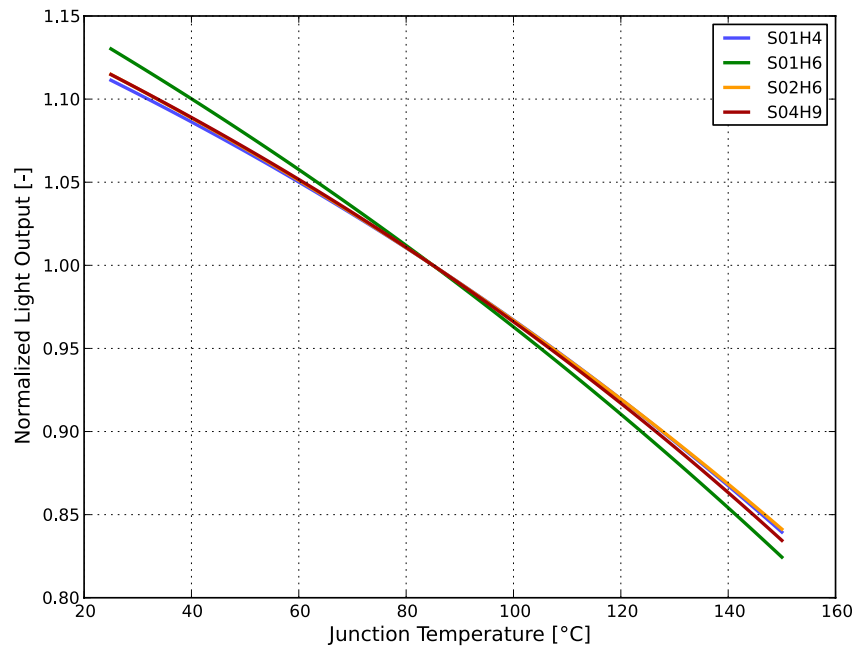

Figure 3. Typical normalized light output vs. junction temperature for LUXEON CX Plus CoB – High Density at specified test current.

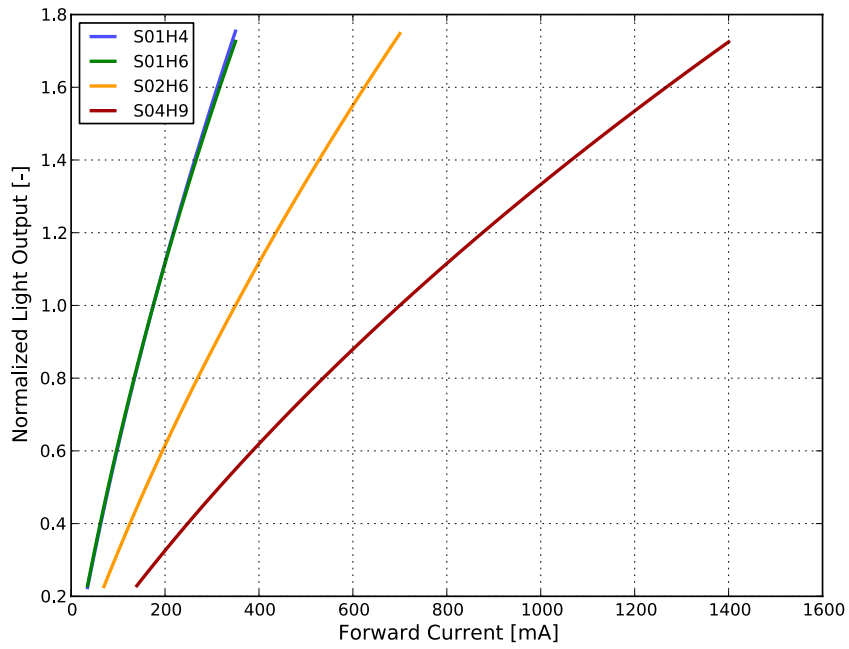

Figure 4. Typical normalized light output vs. forward current for LUXEON CX Plus CoB – High Density at $T_j=85^\circ\text{C}$.

Forward Current Characteristics

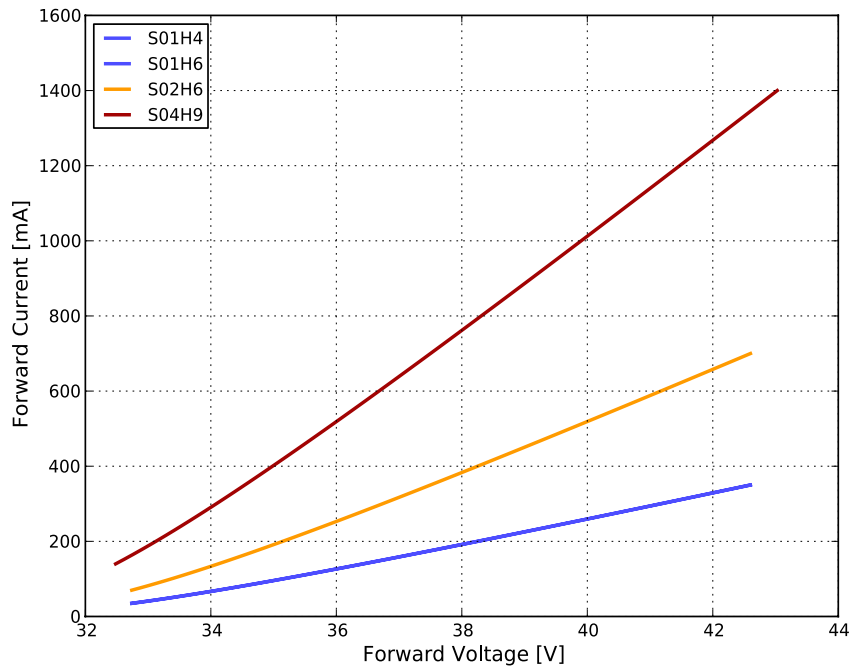

Figure 5. Typical forward current vs. forward voltage for LUXEON CX Plus CoB – High Density at $T_j=85^\circ\text{C}$.

Radiation Pattern Characteristics

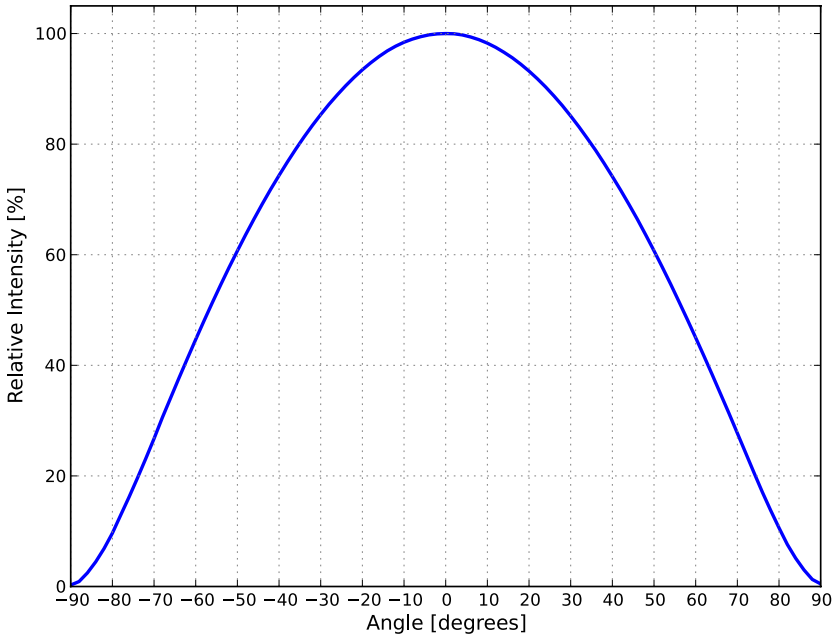

Figure 6. Typical radiation pattern for LUXEON CX Plus CoB – High Density at specified test current, $T_j=85^{\circ}\text{C}$.

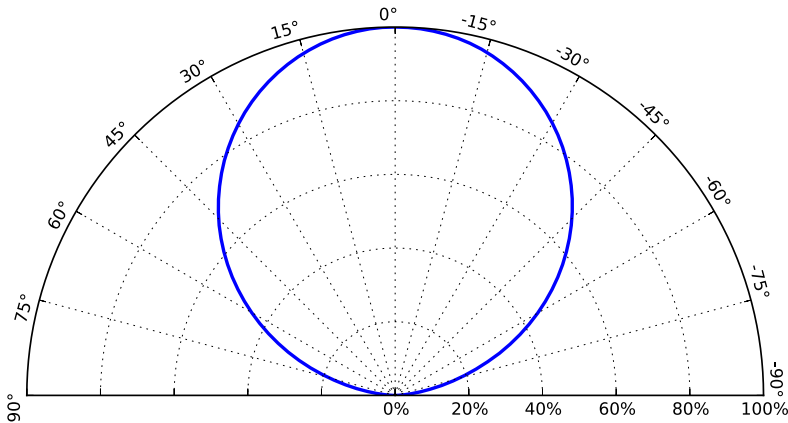

Figure 7. Typical polar radiation pattern for LUXEON CX Plus CoB – High Density at specified test current, $T_j=85^{\circ}\text{C}$.

Color Bin Definitions

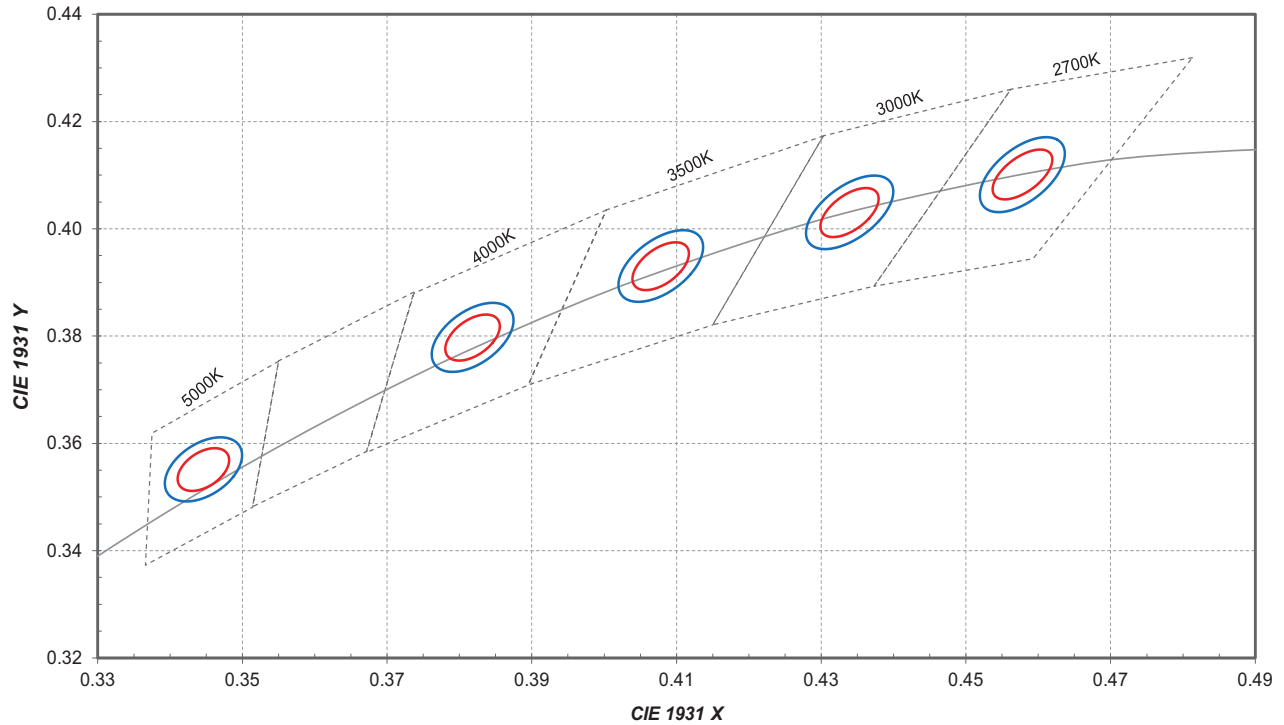

Figure 8. 2- and 3-step MacAdam ellipse illustration for Table 5.

Table 5. 2- and 3-step MacAdam ellipse color bin definitions for LUXEON CX Plus CoB – High Density.

NOMINAL CCT	CENTER POINT ^[1] (cx, cy)	2 SDCM		3 SDCM		ELLIPSE ROTATION ANGLE, θ
		MAJOR AXIS, a	MINOR AXIS, b	MAJOR AXIS, a	MINOR AXIS, b	
2700K	(0.4578, 0.4101)	0.00540	0.00280	0.00810	0.00420	53.70°
3000K	(0.4338, 0.4030)	0.00556	0.00272	0.00834	0.00408	53.20°
3500K	(0.4073, 0.3917)	0.00618	0.00276	0.00927	0.00414	54.00°
4000K	(0.3818, 0.3797)	0.00626	0.00268	0.00939	0.00402	53.70°
5000K	(0.3447, 0.3553)	0.00548	0.00236	0.00822	0.00354	59.60°

Notes for Table 5:

1. Lumileds maintains a tolerance of ± 0.005 on x and y coordinates in the CIE 1931 color space.

Mechanical Dimensions

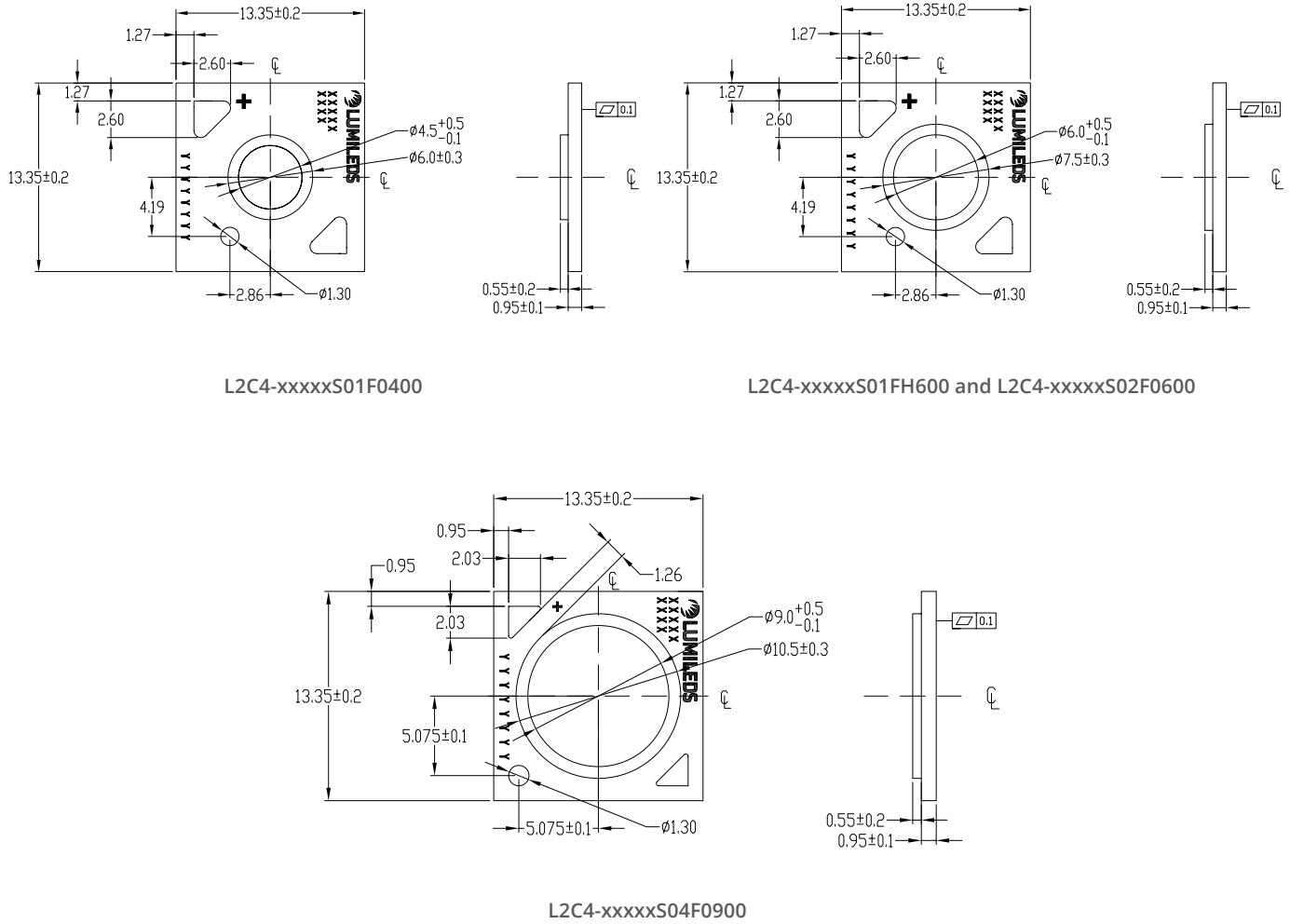

Figure 9. Mechanical dimensions for LUXEON CX Plus CoB – High Density.

Notes for Figure 9:

1. Drawings are not to scale.
2. All dimensions are in millimeters.
3. Diameter and tolerance refer to dielectric opening.

Packaging and Labeling Information

Table 6. Number of LEDs per tray and per inner box for LUXEON CX Plus CoB – High Density.

PART NUMBER	TOTAL UNITS PER TRAY	TOTAL TRAYS PER INNER BOX	TOTAL UNITS PER INNER BOX
L2C4-xxxxxS01F0400	90	2	180
L2C4-xxxxxS01FH600	90	2	180
L2C4-xxxxxS02F0600	90	2	180
L2C4-xxxxxS04F0900	90	2	180

Tray Dimensions

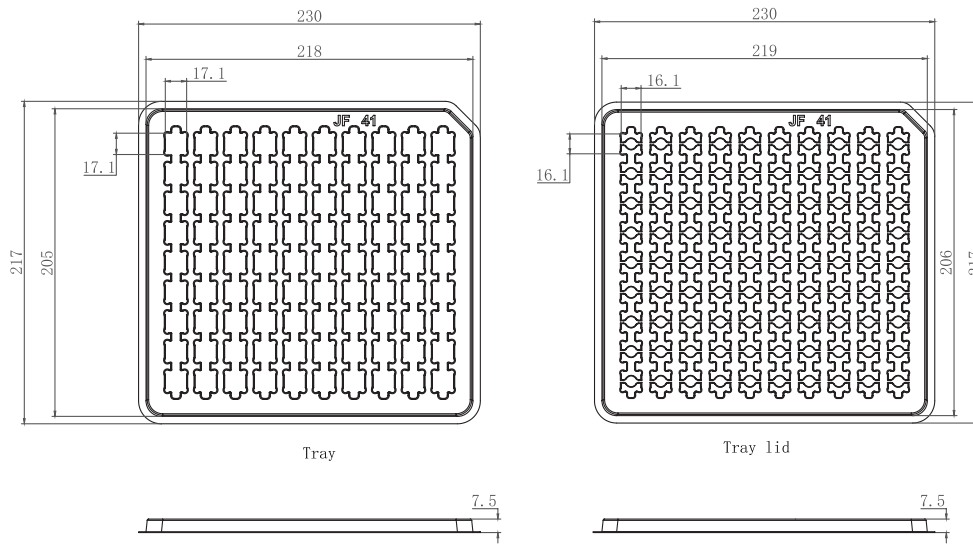

Figure 10. Tray dimensions for LUXEON CX Plus CoB – High Density.

Notes for Figure 10:

1. Drawings are not to scale.
2. All dimensions are in millimeters.

Inner Box

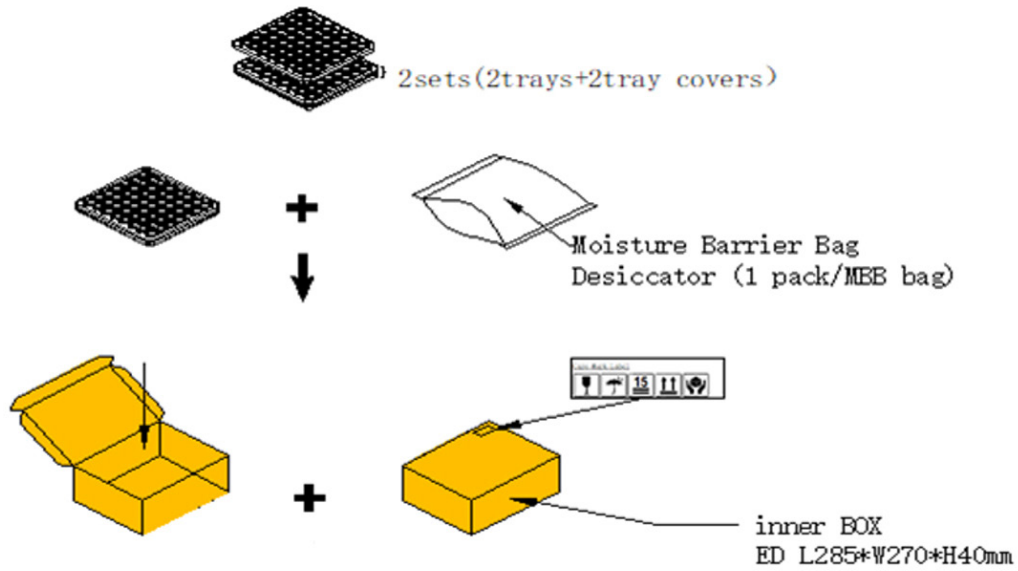

Figure 11. Dimensions for inner box packaging for LUXEON CX Plus CoB – High Density

Table 7. Inner box information for LUXEON CX Plus CoB – High Density.

BOX TYPE	DIMENSIONS (mm)			AVERAGE WEIGHT (180pcs/box)
	H	L	W	
Inner Box	40	285	270	0.385Kg

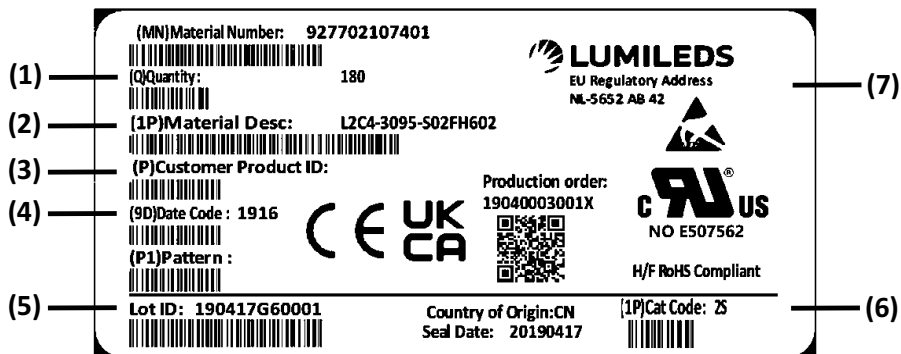

Figure 12. Example of a tray, MBB bag and inner box label for LUXEON CX Plus CoB – High Density.

Notes for Figure 12 – Inner Box Label descriptions for customer use:

Field labels not described are for Lumileds internal use only.

1. Number of LED emitters in an MBB bag.
2. Lumileds part number.
3. Customer part number for custom requests only.
4. LED test date in YYWW format.
5. Unique production lot identification number. This number is required for traceability purpose.
6. Product category code.
7. EU regulatory address.

Outer Box

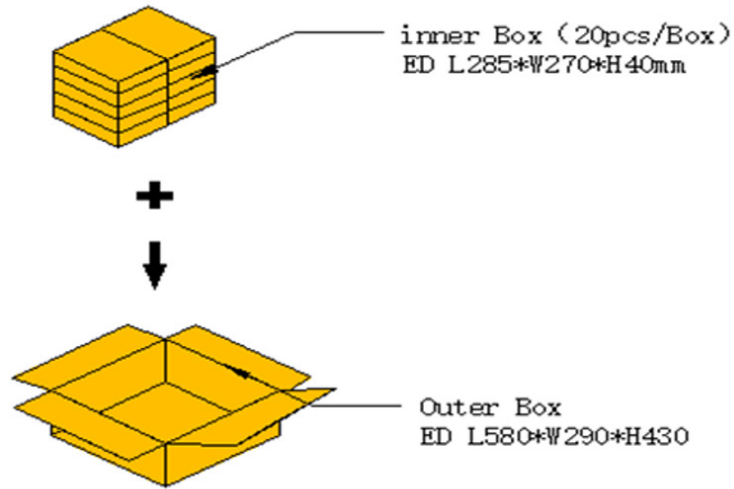

Figure 13. Dimensions for outer box packaging for LUXEON CX Plus CoB – High Density.

Table 8. Outer box information for LUXEON CX Plus CoB – High Density.

BOX TYPE	DIMENSIONS (mm)			MAXIMUM INNER BOXES PER OUTER BOX	MAXIMUM QUANTITY PER OUTER BOX	AVERAGE WEIGHT (3600pcs/box)
	H	L	W			
Outer Box	430	580	290	20	3600	8.6Kg

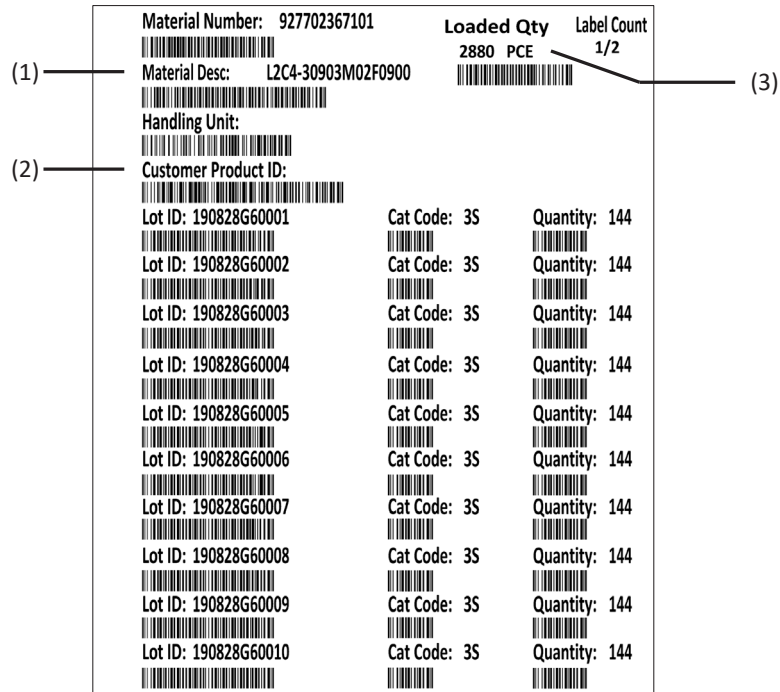

Figure 14. Example of outer box label for LUXEON CX Plus CoB – High Density.

- Notes for Figure 14 – Outer Box Label descriptions for customer use:
 Field labels not described are for Lumileds internal use only.
1. Lumileds part number.
 2. Customer part number for custom requests only.
 3. Total number of LED emitters in a shipment box.

About Lumileds

Lumileds is a global leader in LED and microLED technology, innovation, and solutions for the automotive, display, illumination, mobile, and other markets where light sources are essential. Our approximately 3,500 employees operate in over 15 countries and partner with our customers to deliver never before possible solutions for lighting, safety, and well-being.

To learn more about our lighting solutions, visit lumileds.com.