

LUXEON FX2-L Plus PC Amber

Industry leading solutions for exterior automotive lighting

LUXEON FX2-L Plus PC-Amber LEDs with their Chip Scale Package (CSP) form factor are designed to meet present and future Automotive requirements. The Lumileds automotive binning structure meets both SAE and ECE color specifications and is hot binned at 85 °C, consistent with actual automotive operational environments. LUXEON FX2-L Plus PC-Amber provides industry-leading solutions for your front and rear turn applications. All Luxeon FX2-L PC Amber are AEC-Q102 qualified.

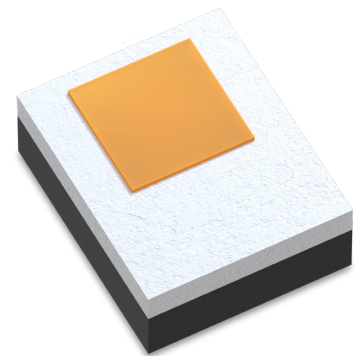

FEATURES AND BENEFITS

High drive current capability for increased flux performance

Compact, robust design with thermal solder pad enables best thermal performance on a wide variety of PCB types

Advanced CSP technology provides leading performance in a cost effective package

Hot binned at 85°C MP to match operating conditions

PRIMARY APPLICATIONS

Sidemarkers

Turn indicators

– Front

– Rear

– Mirror

Table of Contents

General Product Information	2
Product Test and Binning Conditions	2
Part Number Nomenclature	2
Environmental Compliance	2
Performance Characteristics	3
Product Selection Guide	3
Optical Characteristics	3
Electrical and Thermal Characteristics	3
Absolute Ratings	4
Characteristic Curves	5
Spectral Power Distribution Characteristics	5
Light Output Characteristics	5
Forward Current and Forward Voltage Characteristics	6
Color Shift Characteristics	8
Radiation Pattern Characteristics	9
Operating Limits Characteristics	10
Permissible Pulse Handling Characteristics	10
Product Bin and Labeling Definitions	11
Decoding Product Bin Labeling	11
Luminous Flux Bins	11
Color Codes	12
Color Bin Definitions	12
Forward Voltage Bins	13
Mechanical Dimensions	14
Package Weight	14
JEDEC Moisture Sensitivity	14
Packaging Information	15
Pocket Tape Dimensions	15
Reel Dimensions	15
Product Labeling	16

General Product Information

LUXEON FX2-L Plus PC-Amber emitters are high-power Lumiramic® Phosphor converted InGaN emitters mounted on an AlN package. All LUXEON FX2-L Plus PC-Amber emitters contain a TVS chip for ESD protection.

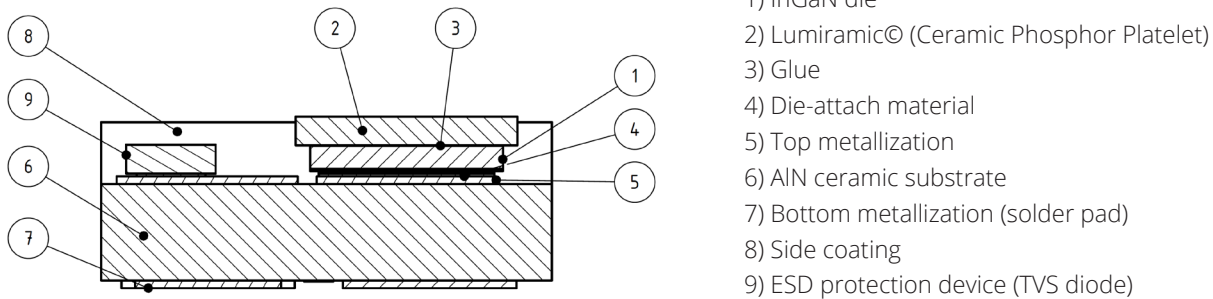

Figure 1. Schematic cross section LUXEON FX2L Plus PC-Amber

Product Test and Binning Conditions

Monopulse (MP) testing for LUXEON FX2L Plus PC-Amber is done with a pulse of 7 ms. The binning conditions for LUXEON FX2 L Plus PC-Amber are MP testing at 1000 mA at a temperature of 85 °C:

Part Number Nomenclature

Part numbers for LUXEON FX2-L Plus PC-Amber follow the convention below:

A 1 F 2 – **B B B B** C D E **F G G G G H**

Where:

- B B B B** – designates color temperature or wavelength (0591= Amber)
- C** – designates Lumiramic size (F = 1150 um)
- D** – designates form factor (3 = 3PAD)
- E** – designates product generation
- F** – designates future product offering (default = 0)
- G G G G** – designates minimum luminous flux (example: 0280 = 280 lumens)
- H** – designates options code for distribution (default = 0)

Therefore, the following part number is used for a LUXEON FX2-L Plus PC-Amber with a minimum luminous flux of 280 lumens:

A 1 F 2 – **0 5 9 1** F 3 C **0 0 2 8 0 0**

Environmental Compliance

Lumileds LLC is committed to providing environmentally friendly products to the solid-state lighting market. LUXEON FX2-L Plus PC-Amber is compliant to the European Union directives on the restriction of hazardous substances in electronic equipment, namely the RoHS Directive 2011/65/EU and REACH Regulation (EC) 1907/2006. Lumileds LLC will not intentionally add the following restricted materials to its products: lead, mercury, cadmium, hexavalent chromium, polybrominated biphenyls (PBB) or polybrominated diphenyl ethers (PBDE).

Performance Characteristics

Product Selection Guide

Table 1. Product performance and optical characteristics of LUXEON FX2-L Plus PC-Amber at MP binning conditions

MINIMUM LUMINOUS FLUX ^[1] (lm)	PART NUMBER
250	A1F2-0591F3C002500
260	A1F2-0591F3C002600
270	A1F2-0591F3C002700
280	A1F2-0591F3C002800

Notes for Table 1:

1. Lumileds maintains a tolerance of $\pm 6.5\%$ on luminous flux measurements.

Optical Characteristics

Table 2. Optical characteristics for LUXEON FX2-L Plus PC-Amber at MP binning conditions and far-field optical characteristics.

PART NUMBER	Dominant Wavelength (nm) ^[1]		SPECTRAL HALF-WIDTH (NM) ^[2] $\Delta\lambda_{1/2}$	TYPICAL TOTAL INCLUDED ANGLE ^[3]	TYPICAL VIEWING ANGLE ^[4] $2\theta_{1/2}$
	MINIMUM	MAXIMUM			
A1F2-0591F3Cxxxxxx	588.8	592.6	77	140°	120°

Notes for Table 2:

1. Dominant wavelength is measured at binning condition.
2. Spectral width at 1/2 of the peak intensity.
3. $2\theta_{0.90V}$ denotes the total angle at which 90% of total luminous flux is captured, i.e. the cone defined by the off-axis angle $\theta_{0.90V}$ from the LED centerline includes 90% of the total flux
4. $2\theta_{1/2}$ denotes the viewing angle, with $\theta_{1/2}$ being the off-axis angle from the LED centerline where the luminous intensity is $\frac{1}{2}$ of the peak value

Electrical and Thermal Characteristics

Table 3. Electrical and thermal characteristics for LUXEON FX2-L Plus PC-Amber. Electrical characteristics at MP binning condition, thermal characteristics at binning current and 25°C stage temperature

PART NUMBER	FORWARD VOLTAGE (V_f) ^[1] [V]			THERMAL RESISTANCE— JUNCTION TO CASE (K/W)			
	MIN.	TYP.	MAX.	$R\theta_{j-c} \text{ el}$ ^[2]		$R\theta_{j-c} \text{ real}$ ^[3]	
				TYPICAL	MAXIMUM	TYPICAL	MAXIMUM
A1F2-0591F3Cxxxxxx	2.90	3.16	3.35	4.1	4.9	5.6	6.7

Notes for Table 3:

1. Lumileds maintains a tolerance of $\pm 0.06V$ on forward voltage measurements.
2. Ratio between temperature difference (junction to case) and electrical input power (references JESD51-51, JESD51-14).
3. Ratio between temperature difference (junction to case) and dissipated heat, i.e. emitted light taken into account (references JESD51-51, JESD51-14).

Absolute Ratings

Table 4. Absolute ratings for LUXEON FX2-L Plus PC-Amber

PARAMETER	PERFORMANCE
Minimum DC Forward Current	50 mA
Maximum DC Forward Current ^[1]	1000 mA
Maximum Peak Pulsed Forward Current ^[1]	2000 mA
Maximum Emitter Junction Temperature ^[1] (DC & Pulse)	150 °C
Maximum Emitter Junction Temperature ^[1, 2] (DC & Pulse), short term	180 °C
ESD Sensitivity ^[3]	HBM ±8 kV CDM ±2 kV
Operating Case Temperature ^[1]	-40 °C to 135 °C
Emitter Storage Temperature	-40 °C to 135 °C
SMD Process Classification Temperature	260 °C
Allowable Reflow Cycles	3
Reverse Voltage (Vreverse)	Not designed to be driven in reverse bias

Notes for Table 4:

1. Proper current derating must be observed to maintain the junction temperature below the maximum allowable junction temperature.
2. Short time operations of less than 200 hours,
3. Measured using human body model (per ANSI/ANSI/ESDA/JEDEC JS-001-2010), charged device model (AEC Q101-005 rev A).

Characteristic Curves

Spectral Power Distribution Characteristics

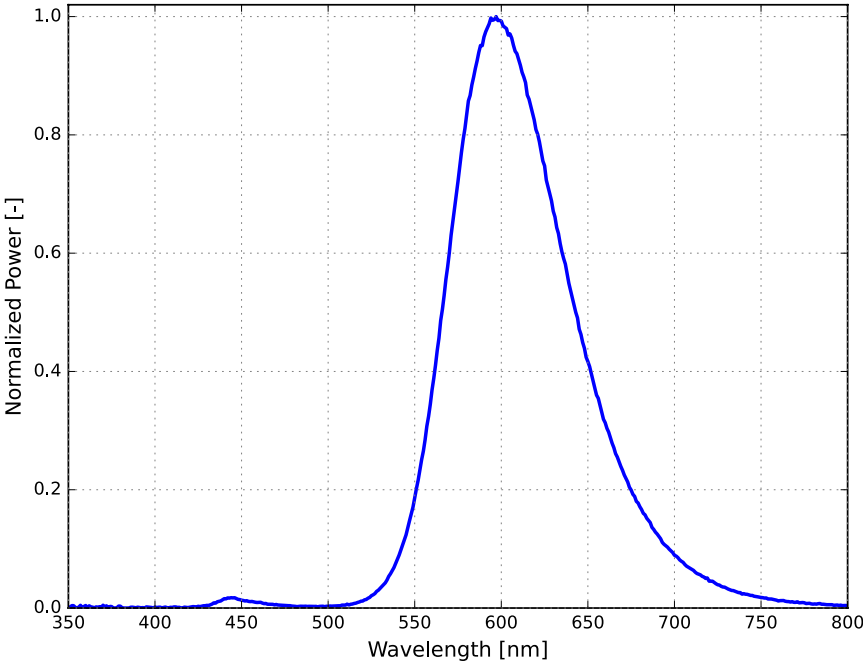

Figure 2. Typical normalized power vs. wavelength for LUXEON FX2-L Plus PC-Amber at MP binning conditions

Light Output Characteristics

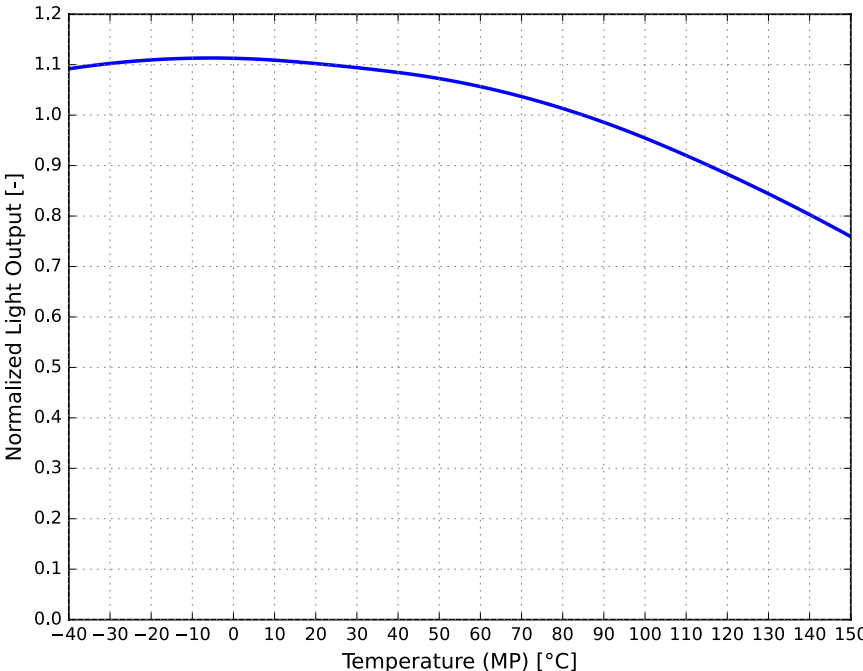

Figure 3. Typical normalized light output vs. temperature for LUXEON FX2-L Plus PC-Amber at MP binning current

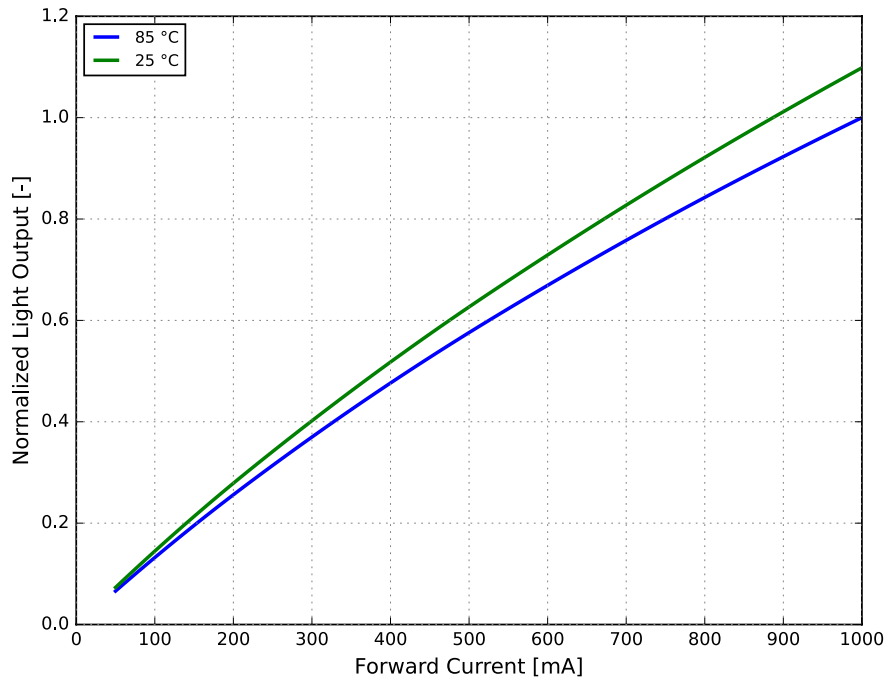

Figure 4. Typical normalized light output vs. forward current for LUXEON FX2-L Plus PC-Amber at MP binning temperature and at room temperature

Forward Current and Forward Voltage Characteristics

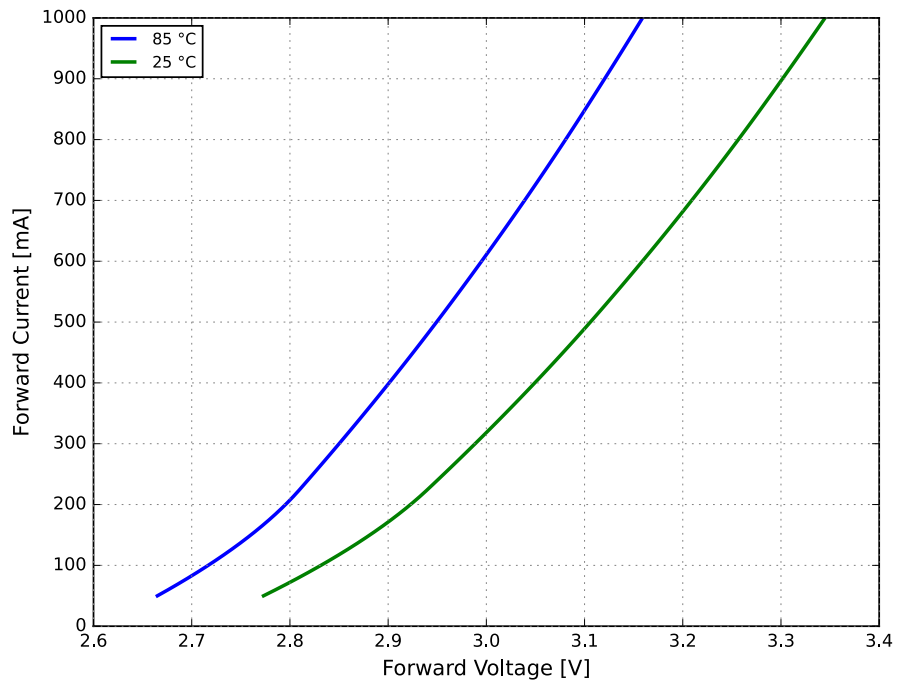

Figure 5. Typical forward current vs. forward voltage for LUXEON FX2-L Plus PC-Amber at MP binning temperature and at room temperature

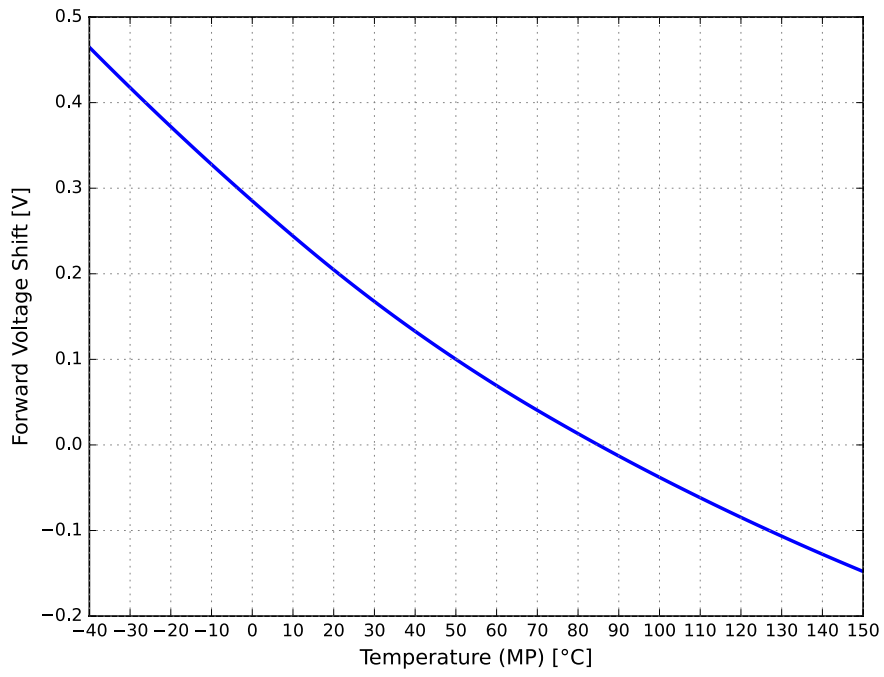

Figure 6. Typical forward voltage shift vs. temperature for LUXEON FX2-L Plus PC-Amber at MP binning current

Color Shift Characteristics

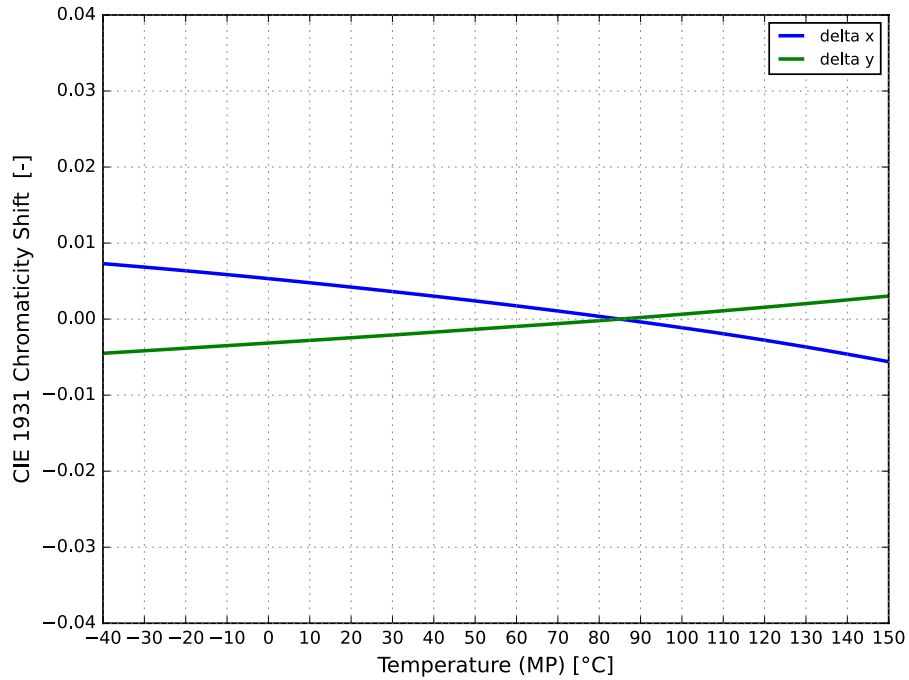

Figure 7. Typical color shift in CIE 1931 x, y coordinates vs. temperature for LUXEON FX2-L Plus PC-Amber at MP binning current

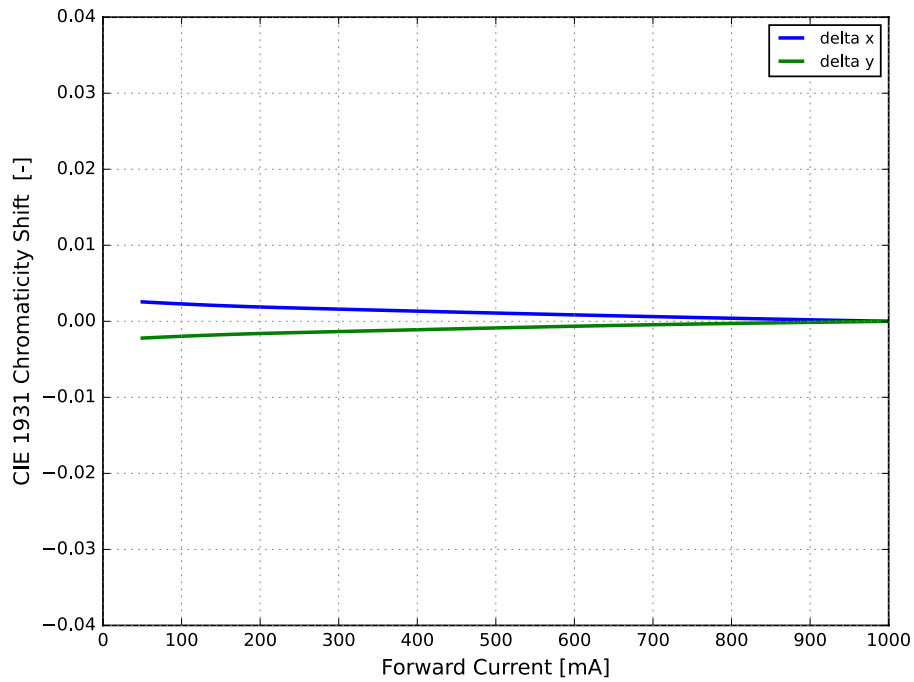

Figure 8. Typical color shift in CIE 1931 x, y coordinates vs. forward current for LUXEON FX2-L Plus PC-Amber at MP binning temperature

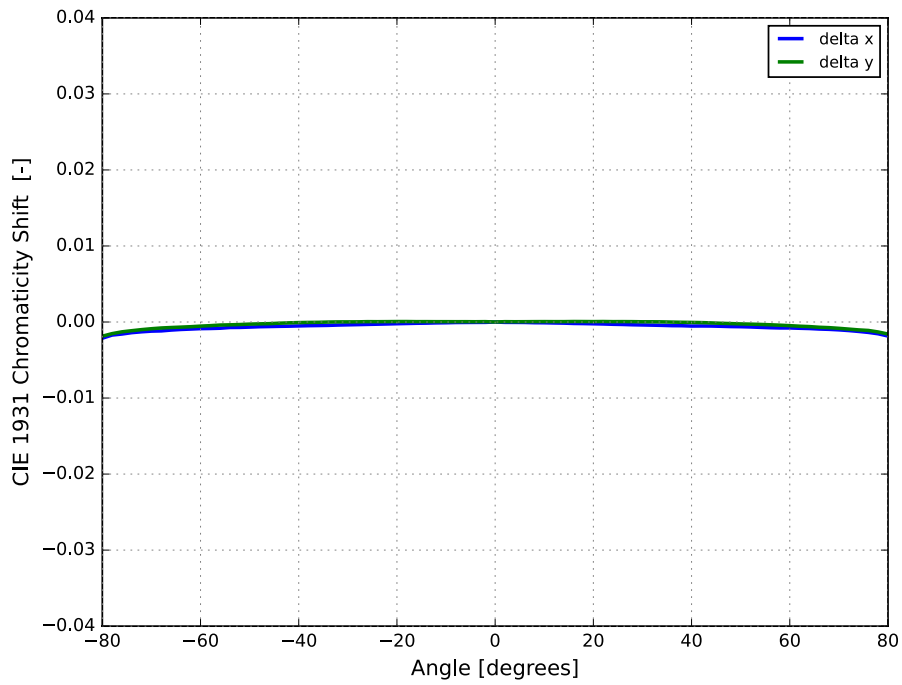

Figure 9. Typical color shift over angle for LUXEON FX2-L Plus PC-Amber

Radiation Pattern Characteristics

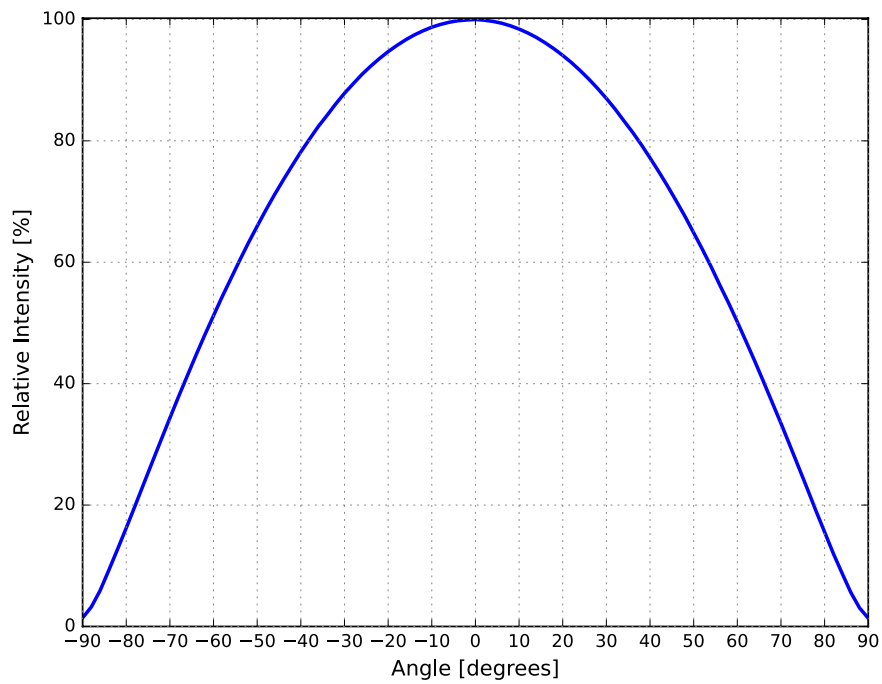

Figure 10. Typical Radiation Pattern for LUXEON FX2-L Plus PC-Amber

Operating Limits Characteristics

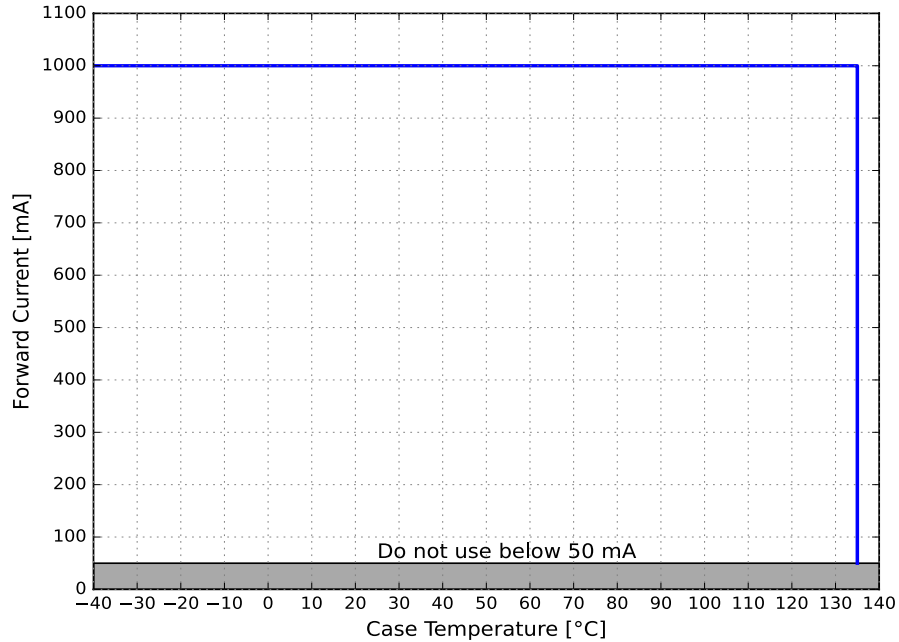

Figure 11. Maximum forward current vs. case temperature for LUXEON FX2-L Plus PC-Amber

Permissible Pulse Handling Characteristics

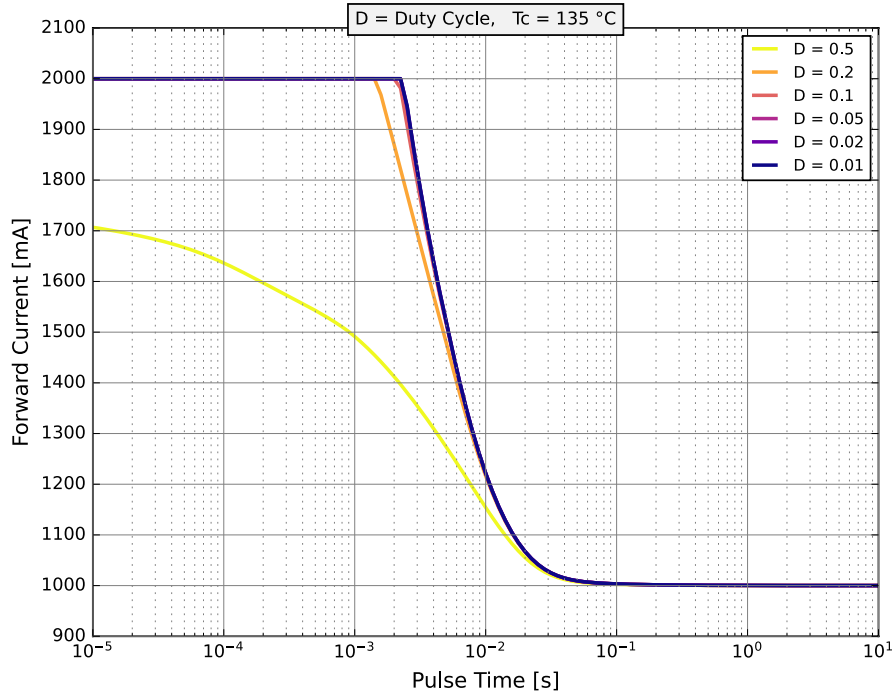

Figure 12. Pulse handling capability for LUXEON FX2-L Plus PC-Amber at maximum case temperature

Product Bin and Labeling Definitions

Decoding Product Bin Labeling

In the manufacturing of semiconductor products, there are variations in performance around the average values given in the technical datasheet. For this reason, Lumileds bins components for luminous flux or radiometric power, color point, peak or dominant wavelength and forward voltage.

LUXEON FX2-L Plus PC-Amber emitters are labeled using a 3-digit alphanumeric CAT code following the format below:

A B C

Where:

- A** – designates luminous flux bin (example: M = 270 to 280 lumens)
- B** – designates color bin (example: A = color bin A)
- C** – designates forward voltage bin (example: B = 2.90 V to 3.20 V)

Therefore, a LUXEON FX2-L Plus PC-Amber with a lumen range of 270 to 280 lumens, color code A and a forward voltage of 2.90 V to 3.20 V has the following CAT code:

M A B

Luminous Flux Bins

Table 5 lists the standard luminous flux bins for LUXEON FX2-L Plus PC-Amber emitters. Although several bins are outlined, product availability in a particular bin varies by production run and by product performance

Table 5. Luminous flux bin definitions for LUXEON FX2-L Plus PC-Amber at MP binning conditions

BIN	LUMINOUS FLUX ^[1] (lm)	
	MINIMUM	MAXIMUM
K	250	260
L	260	270
M	270	280
N	280	290
P	290	300
Q	300	310

Notes for Table 5:

1. Lumileds maintains a tolerance of $\pm 6.5\%$ on luminous flux measurements.

Color Codes

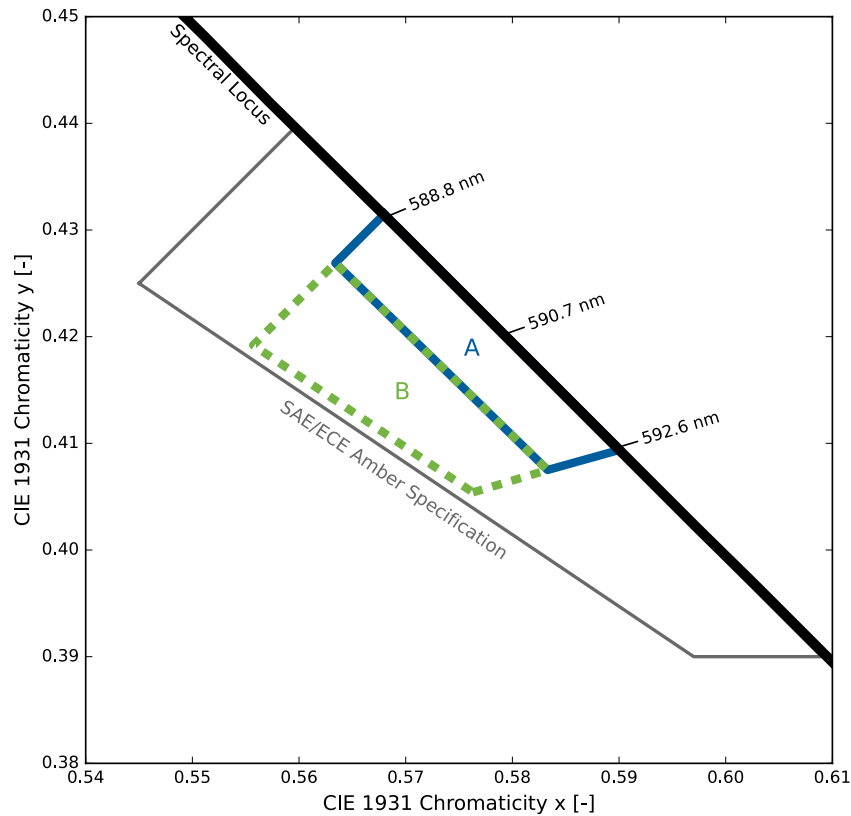

Figure 13. Color bin structure for LUXEON FX2-L Plus PC-Amber

Color Bin Definitions

Table 6. Color bin definitions for LUXEON FX2-L Plus PC-Amber^[1]

BIN	x	y
A	0.568	0.4315
	0.5634	0.4269
	0.5833	0.4075
	0.5901	0.4094
B	0.5763	0.4054
	0.5833	0.4075
	0.5634	0.4269
	0.5557	0.4192

Notes for Table 6:

1. Lumileds maintains a tester tolerance of ± 0.005 on CIE1931 x, y color coordinates.

Forward Voltage Bins

Forward voltage distribution of Lumileds LEDs is very narrow, nevertheless for some applications the restriction of forward voltage is beneficial. On request individual bins are available according to Table 7.

Table 7. Forward voltage bin definitions for LUXEON FX2-L Plus PC-Amber at MP binning conditions

BIN	FORWARD VOLTAGE ⁽¹⁾ (V _f)	
	MINIMUM	MAXIMUM
B	2.90	3.20
C	3.20	3.35

Notes for Table 7:

1. Lumileds maintains a tolerance of ±0.06V on forward voltage measurements.

Mechanical Dimensions

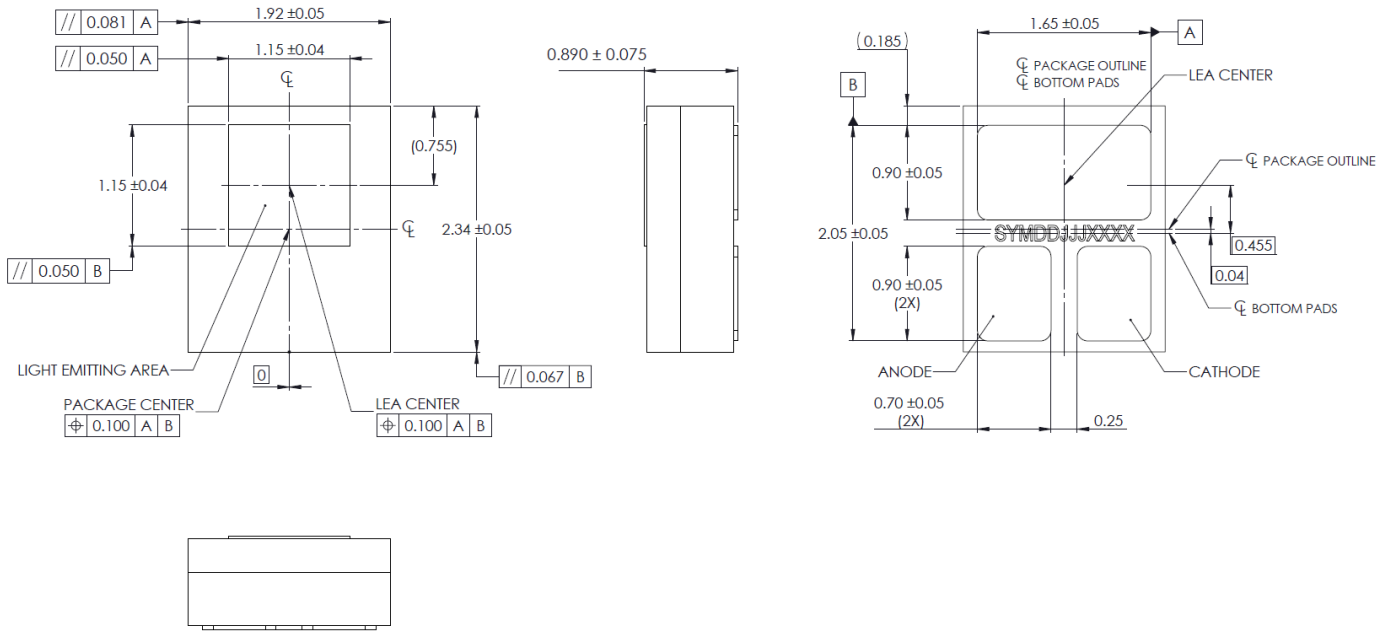

Figure 14. Mechanical dimensions for LUXEON FX2-L Plus PC-Amber

- Notes for Figure 14:
1. Drawings are not to scale.
 2. All dimensions are in millimeters.

Package Weight

Table 8. Approximate weight of LUXEON FX2-L Plus PC-Amber

PART NUMBER	PACKAGE WEIGHT [mg]
A1F2-0591F2Cxxxxxx	13.1

JEDEC Moisture Sensitivity

Table 9. Moisture sensitivity levels for LUXEON FX2-L Plus PC-Amber

LEVEL	FLOOR LIFE		STANDARD SOAK REQUIREMENTS	
	TIME	CONDITIONS	TIME	CONDITIONS
1	Unlimited	≤30 °C / 85% RH	168 Hours +5 / -0	85 °C / 85% RH

Packaging Information

Pocket Tape Dimensions

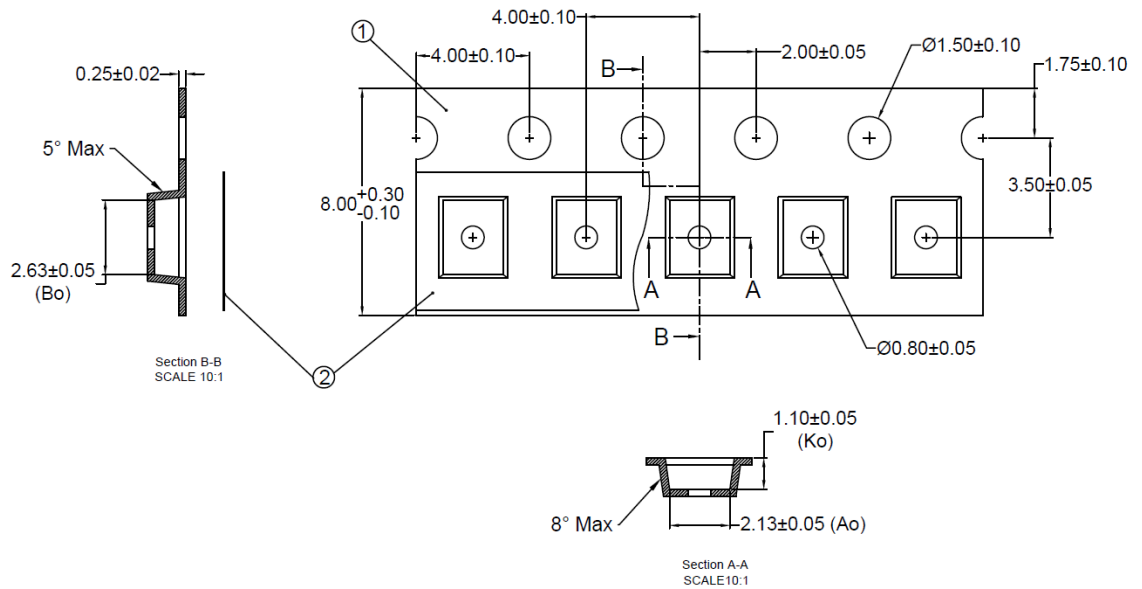

- ① Carrier Tape
- ② Cover Tape

Figure 15. Pocket tape dimensions for LUXEON FX2-L Plus PC-Amber

Notes for Figure 15:

1. Drawings are not to scale.
2. All dimensions are in millimeters.
3. Ao is the width of pocket and Ko is the depth of pocket. Bo is the height of pocket.

Reel Dimensions

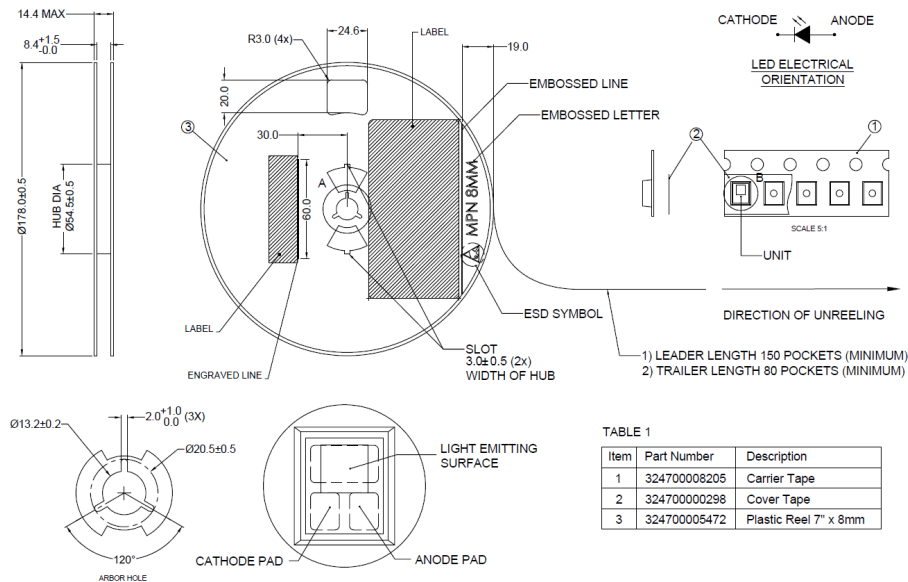

Item	Part Number	Description
1	324700008205	Carrier Tape
2	324700000298	Cover Tape
3	324700005472	Plastic Reel 7" x 8mm

Figure 16. Reel dimensions for LUXEON FX2-L Plus PC-Amber

Notes for Figure 16:

1. Drawings are not to scale.
2. All dimensions are in millimeters.

Product Labeling

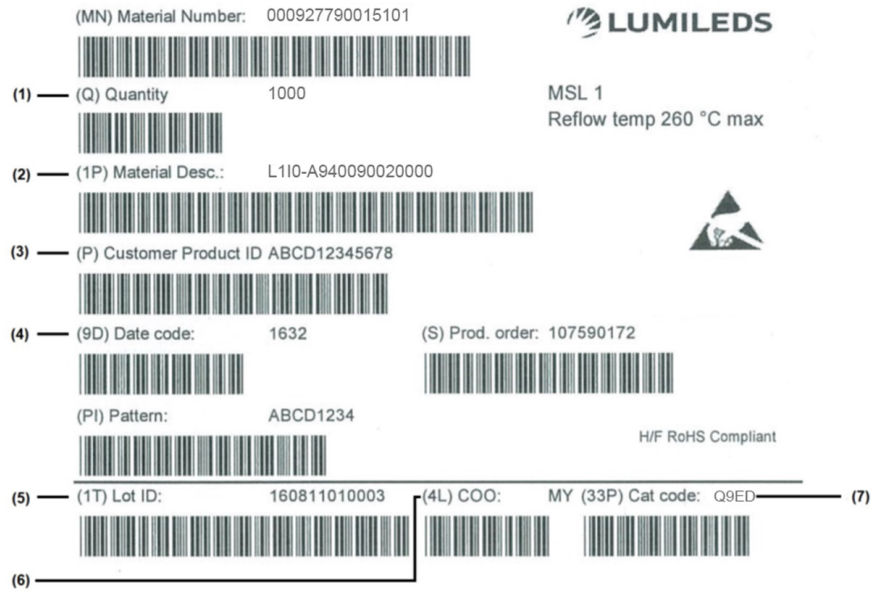

Figure 17. Example of a product label for LUXEON FX2-L Plus PC-Amber

Notes for Figure 17 – Reel label descriptions for customer use:
Field labels not described are for Lumileds internal use only.

1. Total number of LED emitters in a shipment box.
2. Lumileds part number
3. Customer part number for custom requests only.
4. LED test date in YYWW format.
5. Unique product lot identification number. This number is required for traceability purposes.
6. Country code of origin of manufacturing of part (e.g. MY for Malaysia, CN for China) according to ISO 3166-1 alpha-2 document.
7. Product bin 4-digit alphanumeric CAT code.

About Lumileds

Companies developing automotive, mobile, IoT and illumination lighting applications need a partner who can collaborate with them to push the boundaries of light. With over 100 years of inventions and industry firsts, Lumileds is a global lighting solutions company that helps customers around the world deliver differentiated solutions to gain and maintain a competitive edge. As the inventor of Xenon technology, a pioneer in halogen lighting and the leader in high performance LEDs, Lumileds builds innovation, quality and reliability into its technology, products and every customer engagement. Together with its customers, Lumileds is making the world better, safer, more beautiful—with light.

To learn more about our lighting solutions, visit lumileds.com.



©2023 Lumileds Holding B.V. All rights reserved.
LUXEON is a registered trademark of the Lumileds Holding B.V. in the United States and other countries.
lumileds.com

Neither Lumileds Holding B.V. nor its affiliates shall be liable for any kind of loss of data or any other damages, direct, indirect or consequential, resulting from the use of the provided information and data. Although Lumileds Holding B.V. and/or its affiliates have attempted to provide the most accurate information and data, the materials and services information and data are provided “as is,” and neither Lumileds Holding B.V. nor its affiliates warrants or guarantees the contents and correctness of the provided information and data. Lumileds Holding B.V. and its affiliates reserve the right to make changes without notice. You as user agree to this disclaimer and user agreement with the download or use of the provided materials, information and data. A listing of Lumileds product/patent coverage may be accessed at lumileds.com/patents.